



Installation Operation Maintenance

Genius 5 - 15 Tons Diamond 20 - 40 Tons Self Contained Central Air Conditioners

Genius Models

SRVE 050	SAVE 050	SIVE 050
SRVE 075	SAVE 075	SIVE 075
SRVE 100	SAVE 100	SIVE 100
SRVE 125	SAVE 125	SIVE 125
SRVE 150	SAVE 150	SIVE 150

Diamond Models

SAVE 20	SIVE 20
SAVE 25	SIVE 25
SAVE 30	SIVE 30
SAVE 35	SIVE 35
SAVE 40	



SAFETY WARNING

Only qualified personnel should install and service the equipment. The installation, starting up, and servicing of heating, ventilating, and air-conditioning equipment can be hazardous and requires specific knowledge and training. Improperly installed, adjusted or altered equipment by an unqualified person could result in death or serious injury. When working on the equipment, observe all precautions in the literature and on the tags, stickers, and labels that are attached to the equipment.



Contents

I-General Information	3
Genius	4
Diamond	5
II-Installation	12
III-Programmable Thermostat	24
IV-Unit Start-Up	26
V-Operation	29
VI-Maintenance	34
VII-Tools and Equipment	42
VIII-Diagnostics	43
IX-Troubleshooting	44
X-Electrical Diagrams	54
XI-Conversion Table	78

I-General Information

Introduction

This manual describes adequate installation, start-up, operation procedures and servicing and diagnostics for Self-Contained Central Air Conditioners, Genius 5 to 15 Tons and Diamond 20 to 40 Tons.

Available Models

- Model SRVE - Self air condenser, Vertical, E sequence
- Model SAVE - Self water condenser, Vertical, Es sequence
- Model SIVE - Self remote air condenser, Vertical, E sequence

IMPORTANT:

Dimensional measuring units on this catalog are on milimitres (mm). (Except for those locally referencied).

Models Genius and Diamond Self Contained Trane Air Conditioners are autonomous pieces of equipment used for airing, filtering, cooling, dehumidifying and heating air.

They are totally assembled in the factory, duly tested, with correct lubricating oil and refrigerant load, shipped out ready for installation by the customer. They run under the most extreme conditions required by the ARI standard norm (American Refrigeration Institute) (Standard 210/240).

Each refrigerating circuit includes a filter dryer, thermostatic expansion valve. Schrader valves on discharge, suction and liquid lines and high and low pressure switches.

The refrigerant type used is HCFC-22.

The design allows incorporation of several optional items to adequately meet the needs on each installation. Units are supplied with an electro-mechanic standard thermostat.

Optional controls may be the programmable thermostat or Micro processed Control. Figures ahead show the unit layout.

Precautions against product corrosion

It is recommended that air conditioning equipment shall not be installed in environments with a corrosive atmosphere such as acid or alkali gases and environments with a sea breeze. In

need of installing air conditioning equipment in these areas, Trane of Brazil recommends the application of extra protection against corrosion, such as Phenolic protection or the application of ADSIL®. For more information, contact your local distributor.

General Information

Unit Features

Models SRVE AND SAVE

Each unit is composed of a cabinet, one or two Scroll compressors, evaporator, air or water-cooled condenser, motor-fan assembly, air filters, protection and control components, and a standard unit mounted starter.

Each Shell and Tube condenser has an integrated subcooler and may be mechanically or chemically cleaned.

Model SIVE

These units have similar features to the above models, however they have the remote air condenser, models CRCB or CRCE.

Each SIVE is shipped with a dry nitrogen pressurization load and covered pipes.

The CRCB Condenser Unit is more compact, being used in projects where space is an important factor.

The CRCE Condenser Unit has as its major feature the equipment installation flexibility. Since it is built modularly (heat exchanger module and fan module, the equipment enables the installation of the fan module in three discharge options: vertical, frontal horizontal and rear horizontal, thereby meeting the installation option required by you.

Checklists

- A checklist is provided at the end of the installation section to be used by the installer in order to check that all installation procedures have been fully completed.
- Instructions for performing the required checks to execute “start-up” are provided in the Start-Up section.
- A Start-Up Sheet is also provided for recording data of the operation beginning.
- In the Preventive Maintenance section, we provide a Checklist so that the Operator or Service Engineer

set up a routine service schedule. Detailed Maintenance procedures are also specified.

General Safety

TRANE Genius and Diamond Central Air Conditioners are designed to run safely and reliably whenever they are operated in accordance with safety standards.

The system runs on electric and mechanical components, gas and water pressures, etc., which may cause body injuries and equipment damages.

Therefore, only installers with trained and qualified staff should perform installation, start-up and service this equipment.

Follow all safety standards related to work and attention warnings on tags glued to units, as well as use proper tools and equipment.

Hazard Identification



ATTENTION

Attention warnings appear in adequate intervals, in proper points in this manual to alert contractors, operators and service staff about potential hazard situations, which, if are not avoided, MAY result in death or severe body injuries.



CAUTION

Caution warnings appear in adequate intervals, in proper points in this manual to alert contractors, operators and service staff about potential hazard situations, which, if are not avoided, MAY result in death or severe body injuries or damages to equipment.

General Information

Figure I-01 - Self Genius/Diamond Layout

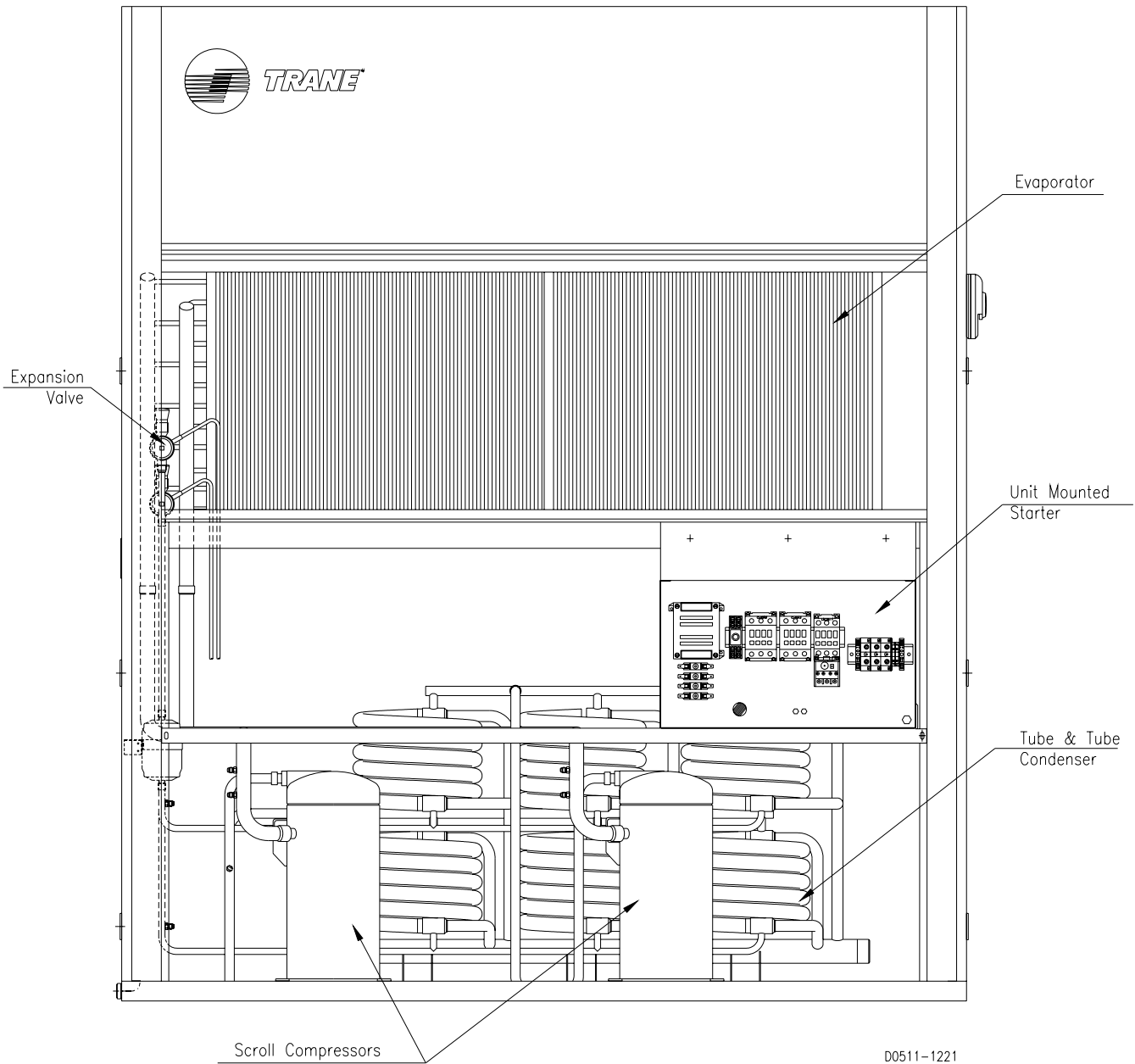

General Information

Figure I-02 - Tag Location

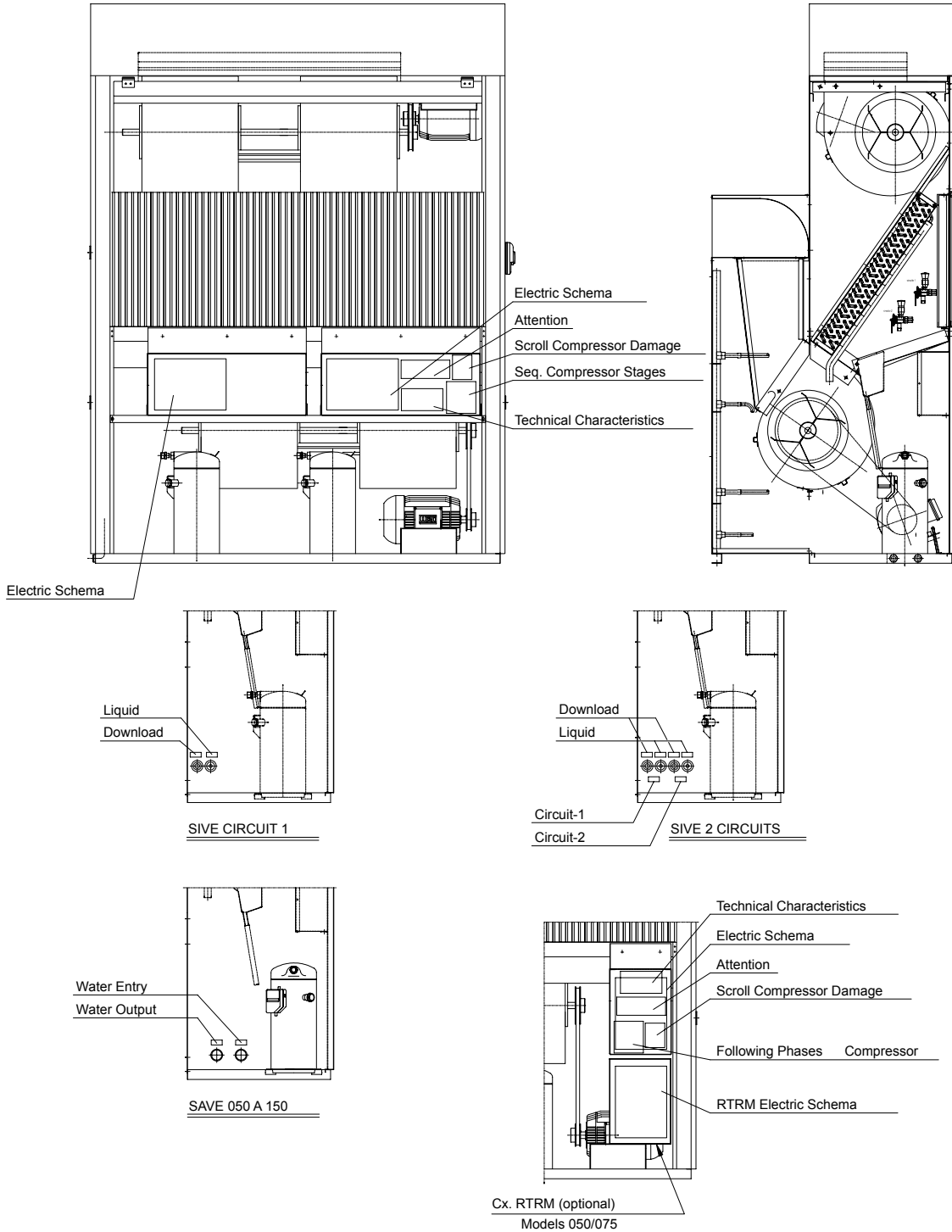

General Information

Genius

Table I-01 - General Data - Self-Contained Genius 050 to 150.

Model		050	075	100	125	150
Nominal Cap.	TR	5	7,5	10	12,5	15
Power Voltage	Volts	220 or 380				
Frequency	Hz	50				
Phase		Three-phase - 3F				
Refrigerant		R407C (Standard)				
No. Circuits		1	1 1	1 2	1 2	1 2
Dimensions						
Lenght	mm	960	1190	1500	1700	1700
Depth	mm	600	600	600	600	600
Depth (SRVE)	mm	720	720	830	1000	1000
Height	mm	2000	2000	2000	2000	2000
Height + Plenum	mm	2295	2295	2295	2295	2295
Equipment Weight (3)						
Self Contained SAVE	kg	247	288	376	440	461
Self Contained SRVE	kg	268	310	416	459	490
Self Contained SIVE	kg	190	225	235	347	392
Cabinet SSVE	kg	154	185	163	271	312
Plenum	kg	28	34	42	48	48
Compressor						
Type		Scroll				
Quantity		1	1	2	2	2
Capacity		5	7,5	5	5 / 7,5	7,5
Evaporator Coil						
Rows		3	3	3	3	4
FPF (Fins per foot)		120	120	120	120	120
Fin type		Corrugated aluminum fins				
Finned face area	m	0,38	1 0,49	1 0,70	1 0,88	1 0,94
Evaporator Fan						
Quantity		1	1 1	1 2	1 2	1 2
Type		Centrifugal				
Diam. x Lenght	mm	270 x 270	321 x 321	270 x 270	321 x 321	321 x 321
Plenum Option	HP	0,5	0,5	0,5	0,5	0,5
Standard Option	HP	1	1,5	1,5	2	2
Option 1	HP	1	2	2	3	4
Option 2	HP	1,5	3	3	4	5
Minimum Air Flow	m³/h	3060	4590	6120	7650	9180
Maximum Air Flow	m³/h	3825	5740	7650	9560	11475
Water-Cooled Condenser (Shell&Tube) - ■ SAVE						
Minimum Water Flow	m³/h	1,4	2	2,7	3,4	4,1
Maximum Water Flow	m³/h	4	6	8	9,9	11,9
Maximum Pressure Loss	mca	1,9	4,6	1,8	3	3,1

Note:

- (1) Capacity are based on ARI 210 for equipments up to 5,0 TR and ARI 340 for equipmentes exceeding 5,0 TR.
- (2) Refrigerant R-407C is not available to the line Self-Contained Genius - SAVE (Water-Cooled Condenser - Shell&Tube).
- (3) Equipment weight refers to the Standard machine.

General Information

Diamond

Table I-02 - General Data - Self Contained Diamond 200 to 400.

Model		SAVE / SIVE	SAVE / SIVE	SAVE / SIVE	SAVE / SIVE	SAVE
		200	250	300	350	400
Nominal Cap. (1)	Ton	20	25	30	45	40
Power Voltage	Volts	220 or 380 or 440 V				
Frequency	Hz	60 Hz				
Phase		Three-Phase - 3F				
Refrigerant		R407C (Standard)				
No. Circuits		2	2	2	2	2
Dimensions						
Lenght	mm	1880	1880	2470	2470	2470
Depth	mm	850	850	980	980	980
Height	mm	2000	2000	2000	2000	2000
Equipment Weight (3)						
Self Contained SAVE	kg	730	745	970	1030	1060
Self Contained SIVE	kg	600	668	800	860	-----
Compressor						
Type		scroll				
Quantity		2	2	2	2	2
Capacity (4)		10	10	10 / 15	15	15 / 20
Evaporator Coil						
Rows		3	4	4	4	4
FPF (Fins per foot)		120	132	132	132	120
Finned type		Corrugated aluminum fins				
Finned face area	m ²	1,71	1,71	2,37	2,45	2,45
Evaporator Fan						
Quantity		2	2	2	2	2
Type		Centrifugal				
Diam. x Lenght	mm	381 x 381	381 x 381	457 x 486	457 x 486	457 x 486
Standard Option	HP	3,0	3,0	3,0	3,0	3,0
Option 1	HP	5,0	5,0	5,0	5,0	5,0
Option 2	HP	7,5	7,5	7,5	7,5	7,5
Option 3	HP	10,0	10,0	10,0	10,0	10,0
Option 4	HP	-----	-----	15,0	15,0	15,0
Minimum Air Flow	m ³ /h	10800	10800	14400	14400	14400
Maximum Air Flow	m ³ /h	19400	19400	27000	27000	27000
Water-Cooled Condenser (Shell&Tube) - SAVE						
Minimum Air Flow	m ³ /h	5,5	6,8	8,2	9,5	11
Maximum Air Flow	m ³ /h	20	20	23,8	27,8	31,8
Maximum Pressure Loss	mca	12	12	12	12	12

Note:

- (1) Capacity are based on ARI 210 for equipments up to 5,0 TR and ARI 340 for equipmentes exceeding 5,0 TR.
- (2) Refrigerant R-407C is not available to the line Self Contained Diamond - SAVE (Water-Cooled Condenser - Shell&Tube).
- (3) Equipment weight refers to the Standard machine.

General Information

Table I-03 - General Data - Condensing Unit CRCE 050 - 150 for use with SIVE.

Remote air condenser CRCE - use with SIVE						
Model	TON	CRCE050	CRCE075	CRCE100	CRCE125	CRCE150
Nominal Cap. ⁽¹⁾		5	7.5	10	12.5	15
Coil						
Type		Micro-channel				
Rows		1	1	1	1	1
FRF (Fins per foot)	ft	276	276	276	276	276
Finned Face Area	m ²	0.55	0.83	0.99	1.38	1.72
Fan motor						
Type		Centrifugal				
Quantity		1	1	2	2	2
Diameter x Length x rotor (es)	in	321 x 321	321 x 321	270 x 270	321 x 321	321 x 321
Motor	hp	1.5	3.0	4.0	4.0	5.0
Nº Phase		3	3	3	3	3
Nominal Power	kW	1.17	2.18	2.83	2.83	3.46
CNO (3)	A	3.85	7.94	9.28	9.28	11.20
CMO (4)	A	4.81	9.93	11.60	11.60	14.00
CRT (5)	A	22.42	77.45	87.00	87.00	106.40
Rotation/ Nº Poles	RPM	1700 / 4	1710 / 4	1720 / 4	1720 / 4	1730 / 4
Air Flow	m ³ /h	5500	8250	9950	13770	15750
Dimensions						
Lenght	in	993	1217	1491	1712	1712
Depth	in	560	560	560	560	560
Height	in	1393	1494	1545	1620	1843
Liquid Weight	kg	148	170	236	278	320

Table I-04 - General Data - Condensing Unit CRCB 050 - 150 for use with SIVE (remote) and SRVE (incorporated)

Remote (w/SIVE) and Built-in (SRVE) Air -Cooled Condenser CRCB						
Model		CRCB050	CRCB075	CRCB100	CRCB125	CRCB150
Nominal Cap. (1)	TR	5	7,5	10	12,5	15
Coil						
Type		Micro-Channel				
Rows		1	1	1	1	1
FPF (Fins per foot)		276	276	276	276	276
Finned face area	m ²	0.55	0.83	0.99	1.38	1.72
Fan motor						
Type		Centrifugal				
Quantity		1	1	2	2	2
Diameter x Length x rotor (es)	in	321 X 321	321 X 321	270x270	321 X 321	321 X 321
Motor	HP	1.0	3.0	4.0	4.0	5.0
Air Flow	m ³ /h	5450	8315	9935	13930	17320
Dimensions - Remote Condenser - CRCB						
Lenght	in	987	1241	1341	1646	1646
Depth	in	631	631	631	714	714
Height	in	890	890	941	1018	1247
Liquid Weight	kg	93	124	139	180	212

Note:

- (1) Capacity are based on ARI 210 for equipments up to 5,0 TR and ARI 340 for equipementes exceeding 5,0 TR.
- (2) Equipment weight refers to the Standard machine.
- (3) RLA = Rated Load Amps (A) - 220V/60hz;
- (4) FLA = Full Load Amps (A) - 220V/60hz;
- (5) LRA = Locked Rotor Amps (A) - 220V/60hz.

II-Installation

Receiving and Handling SRVE/SAVE/SIVE/CRCB

SRVE and SAVE Self-Contained Air Conditioner Units are shipped fully mounted in wooden skid. SIVE units with remote condensers type CRCB/CRCE are shipped in separate parts.

The thermostat to be installed on field is shipped inside the control panel.

Unit Inspection

Upon receiving the unit at the installation site:

- Check whether data contained in the identification plate are the same as that contained in the sales order or shipping list (including electrical features).

- Check whether local power supply complies with the identification plate specifications.

- Inspect carefully the unit for signs of damages in transport.

If inspection performed in unit shows danger or missing materials, place a claim immediately with the transport company. Specify the class and extent of damage before signing the transport bill.

- Notify Trane about damages and steps to be taken for repairs. Do not repair the unit until damages have been inspected.

Storage

In the event the unit is not placed at the definitive installation site, store it in a safe, weather-tight site.

Instructions for Unit Transportation and Handling

For unit transportation and handling, follow the instructions below:

1 - Check the unit weight in the Manual or plate.

2 - Place cables or lifting chains under the wooden skid, as shown in transportation instructions figure.

3 - Avoid that chains, ropes or steel cables contact the conditioner. Use adequate separating rods as shown in the drawing.

4 - Do not remove packing from conditioner until it is in its definitive installation site. Handle it with care.

5 - During transport do not tilt the equipment more than 15° in reference to the vertical.

6 - Always perform the lifting test to determine precise balance and stability of unit prior to lifting it to the installation site.

7 - When moving it horizontally, always use rollers of the same diameter under the wooden skid.



ATTENTION

In order to prevent death or damage to the unit, the equipment lifting capacity must exceed the unit weight by an adequate safety factor.



ATTENTION

Every cable, belt or chain used to lift the unit must have the capacity to support the unit total weight.

Installation

Instructions for a correct installation

For a proper installation, consider the following items prior to placing the unit at the site.

- The engine room should have a good lighting.
- The floor or the unit base should be leveled, solid and sufficiently resistant to support the unit and accessory weight. Level or repair the floor before placing the unit.
- Install rubber skids or vibration insulators under the unit.
- Perform hydraulic installation for draining condensed water.
- For SIVE units with CRCB or CRCE condensers, installer should provide and install the condenser or remote condensers and refrigeration pipes.

- Make electrical installation.
- Inputs for electrical connections are provided for on both sides of the units.
- Provide enough space to have access to pipes and cover removal.
- Power supply should follow Standard NBR 5410, local and/or NEC codes. Electrical data are found in the Product Catalog.
- For SAVE units:
The installer should provide and install water, condensation pumps and cooling tower.

Suggested Spacing for Servicing and Airflow

Provide minimum recommended spaces for maintenance,

servicing and airflow as shown in recommended space for maintenance figures.

Consider the same distances in the event of several units together or in cases of remote condensers. It is very important for optimum equipment running to maintain the distances recommended between the units and between the latter and walls in order to allow a good airflow without hazard of it returning warm to the equipment (air short circuit). Air return is through the front and supply air is through the upper part. Leave a space of at least three fan diameters above the unit to the supply air duct.

Figure II-01 - Transportation Instructions

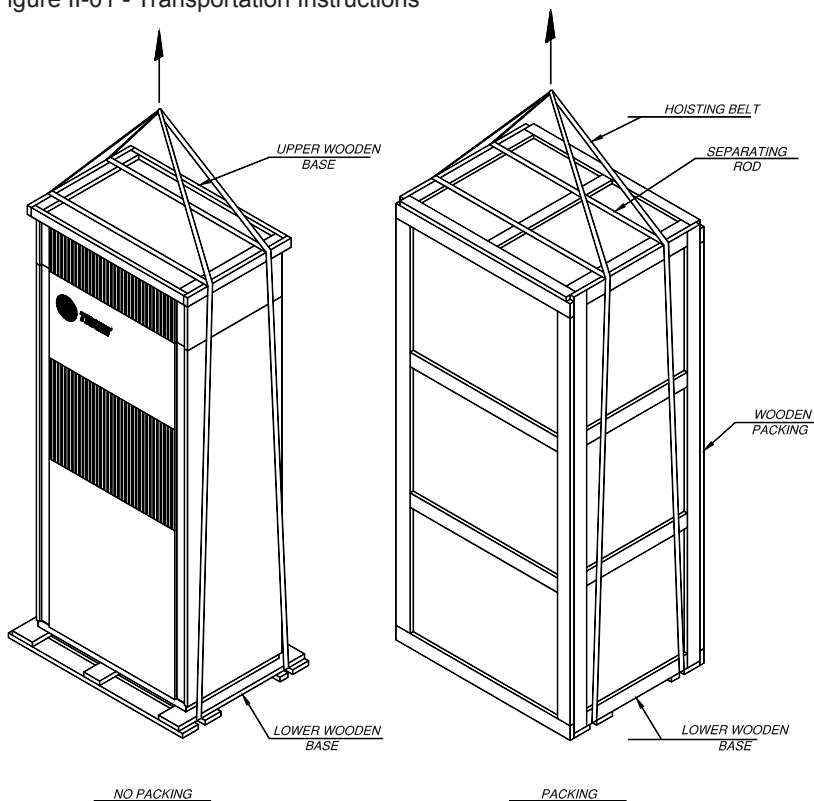

Installation

Figure II-02 - Recommended Spacing for Maintenance and Airflow

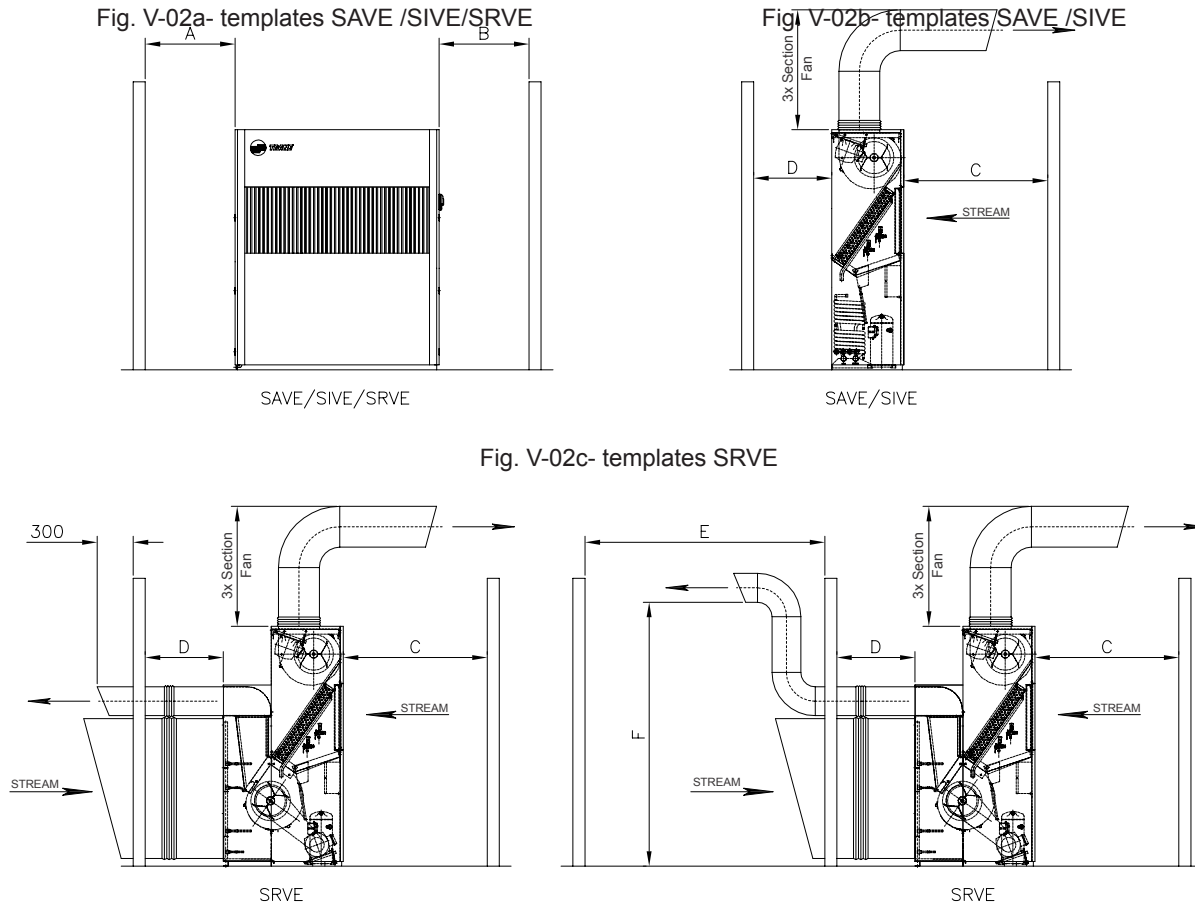

Table II-01 - Free Recommended Spaces

MODEL	CONDENSER	A	B	C	D	E	F
SRVE 050-150	AIR/ EMBEDDED	750	750	1.200	650	2.000	2.200
SAVE 050-150	WATER/ SHELL & TUBE	750	1.700	1.200	650	-	-
	WATER/ TUBE & TUBE	750	750	1.200	650	-	-
SIVE/SSVE 050-150	AIRE/ REMOTE	750	750	1.200	650	-	-
SAVE 200/250	WATER/ SHELL & TUBE	750	1.880	1.200	650	-	-
	WATER/ TUBE & TUBE	750	750	1.200	650	-	-
SAVE 300/350/400	WATER/ SHELL & TUBE	750	2.470	1.200	650	-	-
	WATER/ TUBE & TUBE	750	750	1.200	650	-	-
SIVE 200/250	AIR/ REMOTE	750	750	1.200	650	-	-
SIVE 300/350	AIR/ REMOTE	750	750	1.200	650	-	-
CRCB/CRCE 050 A 150	AIR/ REMOTE	750	750	-	-	2.500	2.500

Installation

Connections for Draining

Genius and Diamond units have two drain outlets in the left side of the units to drain the condensate. A drain interconnects the evaporator pan at the same time by means of a plastic hose. The other drain is from the pan in the base of the Self Contained. Make an independent drain piping for each outlet and a proper trap.

Ductwork Connections

Use a canvas collar with at least 8 cm in the supply/return duct to absorb the vibrations. Install the main duct at a minimum distance of three fan diameters. The main duct must pass as far from the unit as possible, without alterations of size or direction. Such alterations close to the unit are not recommended as they increase the noise and cause static pressure loss. Use streamlets in the curves of the duct to minimize the static pressure losses.

Interconnection of the evaporator unit to the remote condenser

For the installation of the remote condensers, the following cares must be taken:

- The condenser must be in a well-ventilated area;
- The interconnection line between the evaporator and the condenser must be as short as possible;
- Do not reduce the lines gauges;
- Avoid curves in the interconnection line;

- Do not expose the condenser and the liquid line directly to the sun;
- Do not install the condenser in wells and tunnels;
- The condenser and the evaporator must be as close as possible to a horizontal line.

The air conditioners with remote condenser are delivered with vacuum performed and 5-psig nitrogen positive pressure. During the installation, if an absence of pressure is verified, this is a signal of the existence of a leak, which must be fixed before the execution of another vacuum and the refrigerant load. The pipings' welders should be done with silver welder or foscoper. Special care should be taken so that there is no partial or total jam when the lines are welded. The interconnection tubes must not be squashed.

Every welder must be done with nitrogen circulation, through the inside of the tubes that are being welded, to prevent from soot forming. After the interconnection lines are ready, pressurize them with about 200 psig of pressure to search for leaks. Make the vacuum in all the system - interconnection lines and evaporator and condenser units.

Put refrigerant load

Refer to "Servicing Procedures" section in this Manual, to follow the instructions of how to make the vacuum and the refrigerant load and how to gauge the overheating and the subcooling.

Installation

Refrigerant pipings for SIVE models

They are made of copper tubes that interconnect the evaporator and condenser units. The gauges of the connections of the SIVE conditioner and of the CRCB/CRCE

remote condensers and the gauges of the liquid and discharge pipings recommended for the interconnection of both are indicated in the Table below.

Table II-02 - Gauge of Recommended Connections and Pipings per Circuit

Circuit capacity	Connections Gauge (pol)				Piping Equivalent Length							
	SIVE		CRCB / CRCE		up to 6 m		6 to 12m		12 to 23m		23 to 46m	
	Liq.	Desc.	Liq.	Desc.	Liq.	Desc.	Liq.	Desc.	Liq.	Desc.	Liq.	Desc.
5,0	1/2"	5/8"	1/2"	5/8"	1/2"	5/8"	1/2"	3/4"	1/2"	7/8"	5/8"	7/8"
7,5	1/2"	3/4"	1/2"	3/4"	1/2"	3/4"	1/2"	7/8"	1/2"	7/8"	3/4"	1 1/8"
10,0	5/8"	7/8"	5/8"	7/8"	5/8"	7/8"	5/8"	7/8"	5/8"	1 1/8"	3/4"	1 1/8"
12,5	5/8"	1 1/8"	5/8"	1 1/8"	5/8"	1 1/8"	5/8"	1 1/8"	5/8"	1 1/8"	3/4"	1 3/8"
15,0	5/8"	1 1/8"	5/8"	1 1/8"	5/8"	1 1/8"	3/4"	1 1/8"	3/4"	1 1/8"	7/8"	1 3/8"
20,0	7/8"	1 1/8"	7/8"	1 1/8"	7/8"	1 1/8"	7/8"	1 1/8"	7/8"	1 3/8"	7/8"	1 5/8"

Reminder: the equivalent lengths given in the table already include valves, bends, elbows, reducers, etc.. For measuring, you have to consider in the sum of the fridge line total length, the space for necessary connections.

The equivalent lengths indicated include the valves, curves, elbows, reductions, etc. See **Trane** Cooling Manual, which shows the adequate procedures to making the piping

designs. Maximum distance recommended is 24 m. Maximum difference of level recommended between units is 18 m. For greater distances, contact **Trane**. Nominal

load of R407C refrigerant and oil of the equipment is showed on nominal load tables.

Table II-03 - Nominal Load of Refrigerant R-407c and Oil per Circuit - Genius

Model	Compressor		Refrigerant Load - Kg		Oil Initial Load (liters)	
	Cir. 1	Cir. 2	Cir. 1	Cir. 2	Cir. 1	Cir. 2
SRVE050	ZR57		1,6	-	1,95	-
SRVE075	ZR81		2,4	-	1,77	-
SRVE100	ZR57	ZR57	1,6	1,6	1,95	1,95
SRVE125	ZR81	ZR57	2,4	1,6	1,77	1,95
SRVE150	ZR81	ZR81	2,4	2,4	1,77	1,77
SAVE050	ZR57		5,9	-	1,95	-
SAVE075	ZR81		7,5	-	1,77	-
SAVE100	ZR57	ZR57	5,9	5,9	1,95	1,95
SAVE125	ZR81	ZR57	7,5	5,9	1,77	1,95
SAVE150	ZR81	ZR81	7,5	7,5	1,77	1,77
SIVE050	ZR57		1,6	-	1,95	-
SIVE075	ZR81		2,4	-	1,77	-
SIVE100	ZR57	ZR57	1,6	1,6	1,95	1,95
SIVE125	ZR81	ZR57	2,4	1,6	1,77	1,95
SIVE150	ZR81	ZR81	2,4	2,4	1,77	1,77

The kind of oil used is **Trane Oil 48**.

Installation

Table II-04 - Nominal load of Refrigerant R-407c and Oil per Circuit - Diamond

Model	Compressor		Refrigerant (Kg)		Oil Initial Load (liters)	
	Cir. 1	Cir. 2	Cir. 1	Cir. 2	Cir. 1	Cir. 2
SAVE 200	SZ 125	SZ 125	10,5	10,5	3,8	3,8
SAVE 250	SZ 125	SZ 125	11	11	3,8	3,8
SAVE 300	SZ 185	SZ 125	13	11	6,6	3,8
SAVE 350	SZ 185	SZ 185	13	13	6,6	6,6
SAVE 400	SZ 250	SZ 185	15,5	12	3,8+3,8	6,6
SIVE 200	SZ 125	SZ 125	3,3	3,3	3,8	3,8
SIVE 250	SZ 125	SZ 125	3,4	3,4	3,8	3,8
SIVE 300	SZ 185	SZ 125	4,0	3,6	6,6	3,8
SIVE 350	SZ 185	SZ 185	4,0	4,0	6,6	6,6

These loads do not include the refrigerant of pipings to be added. Calculation is made with table below. The refrigerant load will only be correct when overheating and subcooling are respectively at a range of 8 to 12o C and 5 to 10o C.

Table II-05 - Additional refrigerant load (R407C) per meter for remote condensers
REFRIGERANT WEIGHT

Diameter	REFRIGERANT WEIGHT	
	Discharge Line	Liquid Line (Kg/m)
1/2"	-/-	0,110
5/8"	0,009	0,180
3/4"	0,013	0,266
7/8"	0,018	0,370
1 1/8"	0,030	—
1 3/8"	0,046	—

Application Example

Calculate the refrigerant load for a SIVE 200 2T - 20Tons Conditioner - with two CRCB remote condensers - 10 Tons each one, installed 6 meters away.

For each 10 Tons circuit, the quantities of refrigerant below will be needed.

Refrigerant load Circuit

10 Tons - 3,3kgs

Gauge of liquid piping for

6m: - 5/8"

Gauge of discharge piping for

6 m: - 7/8"

Refrigerant load = 3,3 + 6x0,18 + 6x0.018 = 4,5 kgs of R407C for a 10 Tons circuit.

Total load 2 x 4,5 = 9,0 kgs

In installations which real length is more than 20 m, add 0,10 l of oil for each kg of refrigerant added because of the pipings.

*Check additional refrigerant load if needed.

Installation

Recommendations for refrigerating and accessories installation

Condenser Unit above Evaporator Unit

a. Put a trap in the riser base of the discharge line. If the vertical riser exceeds 7,5 m, put an additional trap in each 7,5 m. Install it at the middle of the piping. Make an inverse trap next to the condenser, according to figure above.

b. In the horizontal sections of the discharge line, put a 45 mm inclination in the direction of the flow of refrigerant each 10 meters.

Evaporator Unit above Condenser Unit and at the Same Level

In these cases, it is not necessary to make traps; it is enough to put a 45 mm inclination in the horizontal sections in the direction of the flow, each 10 m.

Figure II-03 - Recommendations For Refrigerating Installation. Condenser Unit above Evaporator Unit

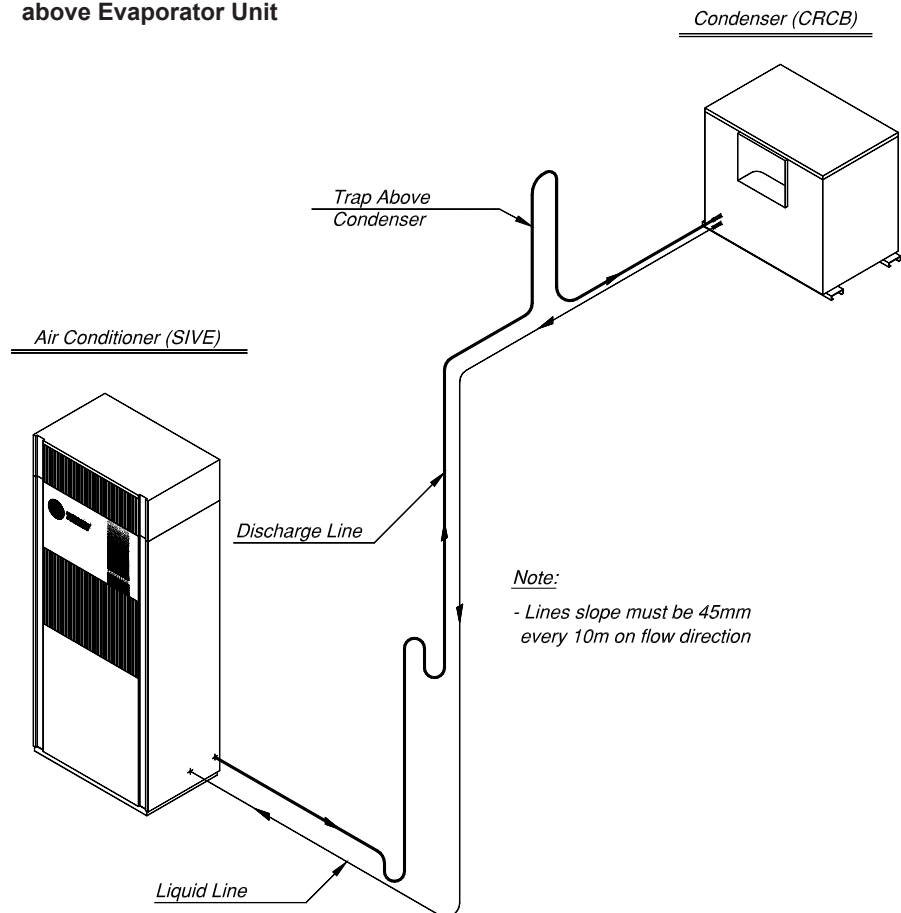

Installation

Hydraulic Pipings

1. The units come out of the factory with the connections at the right side. To invert their positions, change the condenser's tops. Make the supports of the pipings so that the weight does not fall over the tops.

2. Flexible connections:

Install flexible connections on the hydraulic pipings, so that vibrations are not transmitted to the system and to facilitate the system tops removal.

3. Condenser hydraulic piping components:

Cibdebser pinping components figure shows the components and how to make the water piping installation.

4. Condenser drain:

The drain connection must be tubulated to an available strainer to evacuate the condenser even during service. Install a trap.



CAUTION

To avoid damage caused by water, all drains and prurgers must be installed in the pipings

5. Thermometers and pressure gauges: The installation of thermometers and pressure gauges at the entering and leaving of the condensing water is recommended. Such instruments must be installed next to the unit and have 1o C maximum grading for thermometers and 0,1 Kgf/cm2 for pressure gauges.



CAUTION

To avoid damages to the condenser, do not exceed 150PSIG in the water pressure

6. Use joints in the pipings to make the mounting and demounting services easier.

7. The inlet and outlet condensers water pipings should have gate valves, insolated to perform maintenance services and a globe valve in the outlet to regulate the water pressure.

8. Flow regulation is accomplished through regulating the condenser load loss. Graphic in loss pressure Figures. The flow is calculated with the selection program via computer or considering 12 liters per minute, per each cooling ton.
1 Mc a = 0,10 kg/cm2

9. Water flow switch (FLOW-SWITCH)

Check the safety interlockings; particularly the flow-switch should be installed in straight and horizontal sections, with the vains according to the piping diameter; the curves and valves distance must be at least 5 times the diameter of the piping on each side. The flow switch arrow will indicate the direction of the flow.

Figure II-04 - Components of Hidraulic Tubing of Condenser

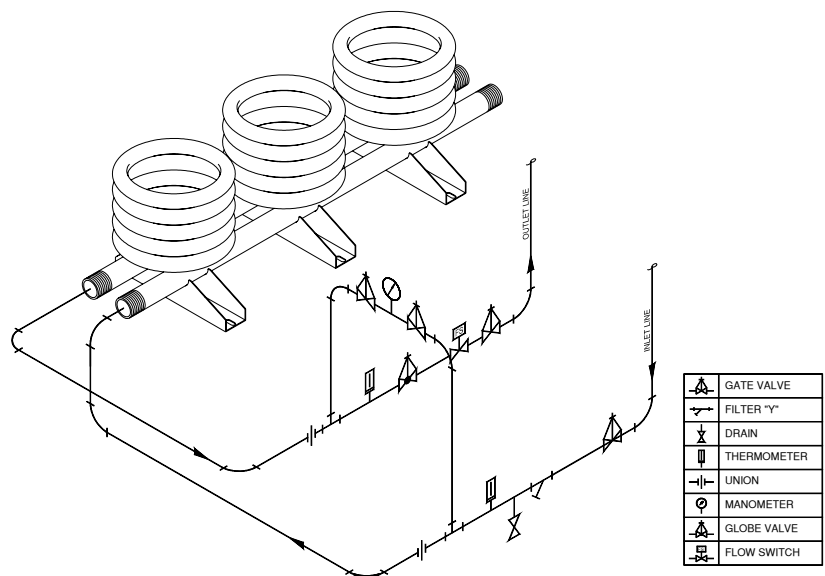

Installation

Water-Cooled Condenser (SAVE)

The water-cooled condenser unit, SAVE, has, Tube & Tube condenser. The hydraulic connection will go through the fabric by the right side, may be change in the field, if necessary.

On the right side see graphics of loss water pressure on condenser.

Figure II-05- Loss Pressure - SAVE Tube & Tube condenser

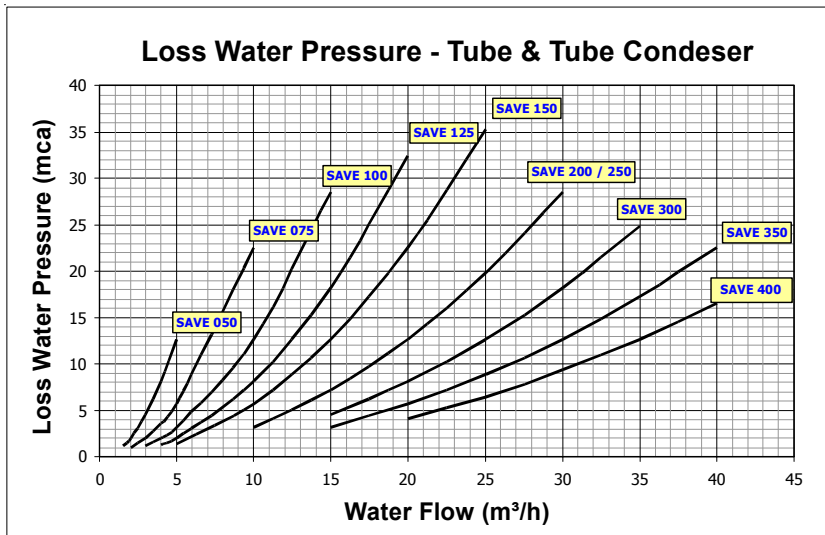
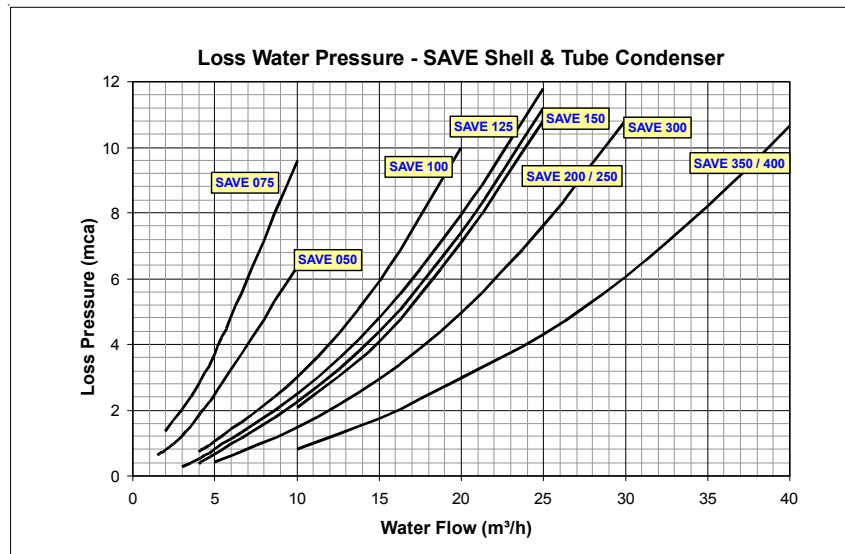

Figure II-06 - Loss Pressure - SAVE Shell & Tube condenser



Installation

Electric Installation

General



ATTENTION

Turn off the electric power to avoid hurt or death due to electrical shock.

Electrical Schemes

The specific electrical schemes of the unit are posted on the inside top of the Electrical Board. Use these schemes to make the connections or to analyze problems. In the Electrical Schemes section, we provide a complete set of the schemes.

1. All of the electric installation should obey the ABTN rules, the local codes and/or the National Electric Code (NEC).
2. Install a non-fused molded case switch next to the Conditioner, with thermomagnetic fuses or circuit breakers.
3. The Installer must provide an electric installation with cable, electrical conduit, fuses, non-fused molded case switches or circuit breakers correctly sized.
4. The electrical cable must be sized by the minimum circuit ampacity, which is calculated by the sum of 125% of the maximum operating current (MOC) of the biggest compressor or motor, plus 100% of the sum of the currents of the others compressors and motors.
5. Electrical features: To get the load in KWs, nominal operating consumption (NOC), maximum operating consumption (MOC), locked rotor current (LRC) and nominal tension, refer to the electric features tables in the Commercial Technical Catalog.

6. Power supply voltage: The power supply for the unit must be strictly appropriate so that the unit runs normally. The voltage provided and the unbalancing between phases must be within the tolerances indicated below. The checking of the power supply and of the unit consumption is important for the equipment and motor safety.

7. The power input can be done through the left or right side of the Unit.

8. The voltage supply may be 220V/380 V/440 V. 3F, 60 Hz. Measure the voltage supplied in all of the phases of the non-fused molded case switches.

The readings must be inside the utilization voltage range showed on the unit's board, that is, the nominal voltage +/- 10%. If the voltage of any of the phases is not within the tolerance, contact the electric company to correct the situation before the equipment breaks.

The maximum unbalancing voltage allowed is 2%.

Inadequate voltage in the unit will cause malfunction in the controls and a reduction of the working life of the contactors contacts and electrical motors.

9. Equipment grounding:

Provide proper grounding in the connections points showed in the control and electrical boards.

CONTROLS

There are three control options:

- Standard Thermostat
- Adaptive Thermostat
- Microprocessor Control

Units are provided with the Standard thermostat, that has got a set of bornes and a rope of cables. It al-

lows that the thermostat is installed in the side of the unit. If necessary, put it in the room or in the engine room for you to have the temperature controlled. The installer must only lengthen the cables identified by colors.

Install the thermostat 1.6 m away from the floor in contact with a free air stream.

Avoid putting it behind doors or in corners where there is no circulation, places where the sun shines upon, surfaces submitted to vibration, walls in contact with the outside air or next to the supply grid outlets.

The Adaptive thermostat has got a liquid crystal display and allows for viewing the hour, day of the week, selected program and room temperature. We can schedule four different "set-points" for each day of the week.

By means of the timed-override key, the user can lengthen the operation of the equipment further on the scheduled times, as desired.

Microprocessor Control

It is a new microprocessor with direct digital control, Proportional/Full. It has got several devices, as easy diagnostics detection and compressors operation in turns, enabling a simple and direct interconnection of the air conditioners to the Tracker Managers or Trace Summit through a twisted pair of wires. The operation instructions are provided in another technical catalog. Refer to a Trane office.

Installation

Installation checklist

Complete this Checklist as soon as the unit is installed to check if all the recommended installation procedures were performed before initializing the unit. This Checklist does not replace the detailed instructions provided in the sections of this Manual. Always read the whole Section to get familiar with the procedures.



ATTENTION

Turn off the electric power to avoid hurt or death due to electrical shock.

Receiving

- Unit and components were inspected to check for damages of shipping.
- The unit was checked for missing material and controls.
- Board data was checked and are identical to the order.

Unit Location

- The unit packing was removed and taken out of the unit. Do not remove the frame until the unit is at the final position.
- The location of the unit is proper for the air ducts, hydraulic pipings and electrical pipings dimensions and for its own dimensions.
- Leave free space around the unit for access and maintenance. Leave space in the front of the tops of “Shell and Tube” condenser for cleaning.

Movement of the Unit

Refer to the item “Instructions for Handling and Moving the Unit” in the installation section.

Unit Mounting

- The unit is placed at the final installation site.
- The wood frame and its screws were removed.
- The Unit is properly installed and the drain has got sinking.
- The rubber skids or the isolators are properly adjusted (if installed).
- The compressors cushions screws were re-tightened (Scroll).
- The packing was removed.

Components Revision

- The fan and the motor axles are parallel.
- The fan and the motor sheaves are aligned.
- The fan belt tension is correctly tensioned.
- The rotors work freely.
- The locking screws, the bearing screws and the sheaves are tight.
- The bearings do not oscillate when they turn.

Air Ducts

- The return duct (if used) to the unit is safe and there is at least 8 cm of flexible or canvas duct.
- The supply duct is installed with no changes in size or direction, at a distance that is three times the diameter. Put at least 8 cm of flexible or canvas duct.
- The main duct is connected to the terminal units, without leaks.
- All the ducts follow ABNT rules.

Installation

Hydraulic Pipings

- The drain piping of the condensing pan is installed.
- The supply and return water pipings are placed with the valves and components recommended in the “Hydraulic Pipings” section.
- Joints were installed to enable the removal of the condenser tops for cleaning.
- A water pump and its backup were installed.
- There is a preventive water treatment to avoid seaweeds, silt, corrosion or incrustations.
- The drains were installed with traps for condensing water flow.

Refrigerant Piping

- When necessary, traps were installed in the discharge line.
- The pipings were leak-tested.
- The refrigerant pipings are not scraping against any object.

Controls

- The control thermostat is correctly installed in an area not submitted to the heat of lamps or behind doors, hot or cold air streams or sunlight.

Electrical Schemes

- Check the electrical scheme posted to the inside top of the electrical board.
- Check if the power supply is made by means of a non-fused molded case switch or circuit breaker to the Air Conditioner Unit.
- Check if a second tight was made in all electric terminals.
- Check the phase and connection sequence in the Unit.

III-Programable Thermostat

Optional

Characteristics

Touchscreen - Easy to read commands as actual temperature and programmable, time are exhibit on principal screen.

Programmable Menu – Shows orientation to programmable process, showing information and necessary options on each screen.

Choose Variety of Days – Allows Easy personalization of exclusive days.

Real-Time Clock – Has automatic system that keeps time running even on powerless. And summer time is adjusted automatically.

Thermostat can be removed from the wall to define calendar.

Precise Temperature Control.

Many options to **OVERRIDE** – Calendar can be modified as many times as its needed, or for a determined period.

Programmable Fan – Raises interior air quality, when combined with cleaning air equipments.

Figure III-01 - Programable Thermostat - Principal Screen.

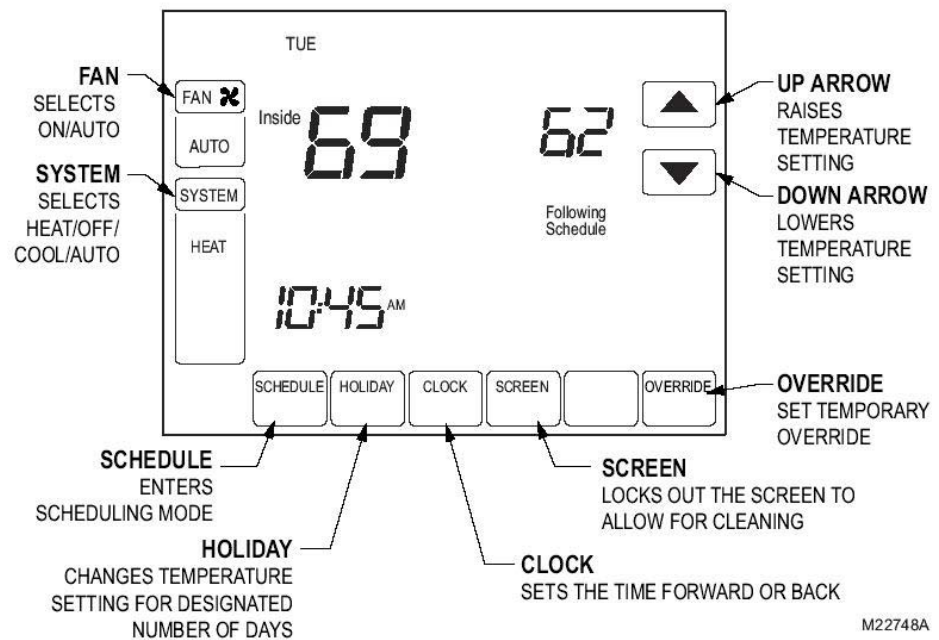

Programable Thermostat

Optional

Specification

Terminal	Voltage (50/60 Hz)	Nominal Current
W (Heating)	20 - 30 Vac	0,02 - 1,0A
Y (Cooling)	20 - 30 Vac	0,02 - 1,0A
G (Fan)	20 - 30 Vac	0,02 - 0,60A
A (Economizator/TOD)	20 - 30 Vac	0,02 - 1,0A

Selectable Temperature Range

Heating: 4,5°C to 32°C
(40°F to 89,6°F)

Cooling: 10°C to 37°C
(50°F to 99°F)

Operation Ambient Temperature

18°C to 49°C (0°F to 120°F)

Stocking Temperature

-34,4°C to 65,5°C (-30°F to 150°F)

Operation Relative Humid (Not Condensable)

5% to 90%

Dimensions

95mm (3-3/4in) height x 152mm
(6in) wide x 35mm (1-3/8in) depth

IV-Unit Start-Up

Start-up checklist

Once the unit is installed, complete each item of this list. When all of them are ok, the unit is ready to start.

- Check if the installation voltage agrees to the voltage of the conditioner.
- Check the phases sequence. It has to be in the clockwise direction.

ATTENTION

If it is necessary to change the phase sequence, change the position of two cables at the inlet.

CAUTION

The compressor scroll must only turn clockwise. Check the phase sequence before starting it.

- Inspect all the electric connections. They must be clean and tight.

ATTENTION

To Avoid accidents or death due electrical shocks, open and lock all the circuit breakers and electric non-fused molded case switches.

- Tighten again the head of the screw or screw-nut against the rubber cushions metal sleeve.
- The operation and shipping position in this kind of cushion is the same.
- Open (contrasede) the suction, liquid and discharge service line valves.
- Confirm if there is no refrigerant leak.
- Gauge the resistance of the motor of the compressor with a 500-volt megohmmeter. The minimum value recommended is 10 megohms.
- Be sure that the direction of rotation of the fan(s) is correct.

- Check the alignment between belts and sheaves.

ATTENTION

To avoid damage in the compressor, do not operate the unit with the suction, discharge and liquid standard isolation valves closed.

- Check if the thermostat is correctly installed.
- Check the operation of all auxiliary equipment, such as condensing water pumps, cooling tower for the water-condensed conditioners, remote condensers, etc.
- Calibrate the air flows in the evaporator and in the condenser (air-condenser).
- Close the circuit breakers or non-fused molded case switches with fuses that furnish power to the start switch of the condensing water pump (Units with water-condensing).
- Turn on the condensing water pump. With the water circulating, check all the connections of the pipings to detect potential leaks. Make repairs, if necessary.
- With the water pump running, adjust the water flow and check the loss of pressure by means of the condenser. Write down the value obtained.
- Adjust the water flow switch in the condensing water piping, checking for its correct operation.
- Turn off the pumps. Now the unit is ready to start.

To start the unit, follow the operation and maintenance instructions and to complete the gas load, follow the procedures explained in the next chapters.

Procedures for the start

Do not start the unit until all of its preparation procedures are complete.

- Check if all items of "Start-up Preparation" described in the previous item were performed.
- Turn on the unit power non-fused molded case switch and the command circuit breakers. Self ON-OFF switch, installed in the thermostat, must be in the OFF position.
- Start the condensing water pumps, locking the power non-fused molded case switches and put the command buttonholes in operation. (For water-condensing units).
- Check the operation sequence of the water pumps and the interlockings operation.
- Check if there is any fan locked and if they are turning freely.
- Check the standard isolation valves of the suction, liquid and discharge lines. These valves must be open (at contrasede) before starting the compressors.

ATTENTION

To avoid damage in the compressor, be sure that all valves are opened before starting the unit

- Turn on Self ON-OFF switch, installed in the thermostat.

Unit Start-Up

Checking the Operational Conditions

Once the unit is operating for about 30 minutes and the system is stabilized, check the operational conditions and complete the checking procedures as follows:

Check the water flow and pressure drops once more by means of the condenser. This reading must be stable and with proper values. If the differential pressure drops, clean all supply water filters.

Check the suction and discharge pressures in the manifold pressure gauges, which hoses were previously turned on.

Discharge Pressures:

Take the discharge pressure with the Schrader valve in the liquid line. The usual pressure values are:

for SRVE/SIVE/SSVE 200 TO 360 psig
for SAVE 185 to 240 psig

Suction Pressure:

Take the suction pressure with the Schrader foreseen in the suction line.

Check and log the amperage used up by the compressor. Compare the readings with the compressor electrical data provided in the equipment board.

Check the liquid sightglass. The refrigerant flow must be clean. Bubbles in the liquid indicate either low refrigerant load or excessive loss of pressure in the liquid line. A restriction may be often identified by a remarkable temperature difference on

each side of the restricted area. Ice is often formed in the liquid line outlet, also at this point.

 **ATTENTION**

The system may not have the correct refrigerant load although the sightglass is clean.

We must also consider the overheating, subcooling and operation pressures

Once the oil level, the amperage and the operation pressures are stabilized, measure the overheating.

Measure the subcooling.

If the operational pressure, the overheating and the subcooling indicate loss of refrigerant, load it in each circuit. The loss of refrigerant is indicated if the working pressures and the subcooling are low.

 **ATTENTION**

If the suction and discharge pressure are low, but the subcooling is normal, there is no lack of refrigerant adding refrigerant will result in overload

Add refrigerant (only in gaseous state) with the unit running, loading gas by means of the Schrader valve placed at the suction line, until the operational conditions are normal.

 **ATTENTION**

To prevent compressor damages, do not allow for the liquid refrigerant get into the suction line.

If the operational conditions indicate gas overload, slowly remove refrigerant through the standard isolation valves of the liquid line. Do not unload refrigerant to the air.

Fill in the "Start Sheet" at the end of this chapter.

 **ATTENTION**

To avoid huts due to freezing, do not let the refrigerant contact the skin.

Once the unit is working normally, keep the engine room clean and the tools at their proper place. Be sure that the control panels doors are in their proper place, too.

System overheating

The normal overheating for each circuit is from 80 C to 120 C at full load. If it is not inside this range, adjust the matchings of the overheating of the expansion valve. Wait for 5 to 10 minutes between each adjustment to allow the expansion valve to stabilize.

System subcooling

The normal subcooling for each circuit is from 5 to 100 C at full load. If the subcooling is not inside this range, check the circuit overheating and, if necessary, make adjustments.



Unit Start-Up

Figure IV-01 - Start-Up Sheet

	START-UP SHEET SELF CONTAINED
MODEL _____	SERIE Nº _____
CLIENT _____	CONTAT _____
ADDRESS _____	
CITY _____	STATE _____

CHECK UP LIST																																									
CIRCUIT 1	CIRCUIT 2																																								
<table style="width: 100%; border-collapse: collapse;"> <tr> <td style="width: 50%; border-right: 1px solid black;"> <table style="width: 100%; border-collapse: collapse;"> <tr><td style="text-align: center;">YES</td><td style="text-align: center;">NO</td></tr> <tr><td style="text-align: center;">01 - LICKING</td><td style="text-align: center;">01 - LICKING</td></tr> <tr><td style="text-align: center;">02 - VIBRATION</td><td style="text-align: center;">02 - VIBRATION</td></tr> <tr><td style="text-align: center;">03 - BUBLING SIGHT</td><td style="text-align: center;">03 - BUBLING SIGHT</td></tr> <tr><td style="text-align: center;">04 - NORMAL OIL LEVEL</td><td style="text-align: center;">04 - NORMAL OIL LEVEL</td></tr> <tr><td style="text-align: center;">05 - CRANKCASE RESISTENC ACTUING</td><td style="text-align: center;">05 - CRANKCASE RESISTENC ACTUING</td></tr> <tr><td style="text-align: center;">06 - NORMAL VOLTAGE</td><td style="text-align: center;">06 - NORMAL VOLTAGE</td></tr> <tr><td style="text-align: center;">07 - HIGH PRESSOSTAT, ON/OFF:</td><td style="text-align: center;">07 - HIGH PRESSOSTAT, ON/OFF:</td></tr> <tr><td style="text-align: center;">08 - LOW PRESSOSTAT, ON/OFF:</td><td style="text-align: center;">08 - LOW PRESSOSTAT, ON/OFF:</td></tr> <tr><td style="text-align: center;">09 - CONTROL THERMOSTAT (SETTINGS)</td><td style="text-align: center;">09 - CONTROL THERMOSTAT (SETTINGS)</td></tr> </table> </td> <td style="width: 50%;"> <table style="width: 100%; border-collapse: collapse;"> <tr><td style="text-align: center;">YES</td><td style="text-align: center;">NO</td></tr> <tr><td style="text-align: center;">01 - LICKING</td><td style="text-align: center;">01 - LICKING</td></tr> <tr><td style="text-align: center;">02 - VIBRATION</td><td style="text-align: center;">02 - VIBRATION</td></tr> <tr><td style="text-align: center;">03 - BUBLING SIGHT</td><td style="text-align: center;">03 - BUBLING SIGHT</td></tr> <tr><td style="text-align: center;">04 - NORMAL OIL LEVEL</td><td style="text-align: center;">04 - NORMAL OIL LEVEL</td></tr> <tr><td style="text-align: center;">05 - CRANKCASE RESISTENC ACTUING</td><td style="text-align: center;">05 - CRANKCASE RESISTENC ACTUING</td></tr> <tr><td style="text-align: center;">06 - NORMAL VOLTAGE</td><td style="text-align: center;">06 - NORMAL VOLTAGE</td></tr> <tr><td style="text-align: center;">07 - HIGH PRESSOSTAT, ON/OFF:</td><td style="text-align: center;">07 - HIGH PRESSOSTAT, ON/OFF:</td></tr> <tr><td style="text-align: center;">08 - LOW PRESSOSTAT, ON/OFF:</td><td style="text-align: center;">08 - LOW PRESSOSTAT, ON/OFF:</td></tr> </table> </td> </tr> </table>	<table style="width: 100%; border-collapse: collapse;"> <tr><td style="text-align: center;">YES</td><td style="text-align: center;">NO</td></tr> <tr><td style="text-align: center;">01 - LICKING</td><td style="text-align: center;">01 - LICKING</td></tr> <tr><td style="text-align: center;">02 - VIBRATION</td><td style="text-align: center;">02 - VIBRATION</td></tr> <tr><td style="text-align: center;">03 - BUBLING SIGHT</td><td style="text-align: center;">03 - BUBLING SIGHT</td></tr> <tr><td style="text-align: center;">04 - NORMAL OIL LEVEL</td><td style="text-align: center;">04 - NORMAL OIL LEVEL</td></tr> <tr><td style="text-align: center;">05 - CRANKCASE RESISTENC ACTUING</td><td style="text-align: center;">05 - CRANKCASE RESISTENC ACTUING</td></tr> <tr><td style="text-align: center;">06 - NORMAL VOLTAGE</td><td style="text-align: center;">06 - NORMAL VOLTAGE</td></tr> <tr><td style="text-align: center;">07 - HIGH PRESSOSTAT, ON/OFF:</td><td style="text-align: center;">07 - HIGH PRESSOSTAT, ON/OFF:</td></tr> <tr><td style="text-align: center;">08 - LOW PRESSOSTAT, ON/OFF:</td><td style="text-align: center;">08 - LOW PRESSOSTAT, ON/OFF:</td></tr> <tr><td style="text-align: center;">09 - CONTROL THERMOSTAT (SETTINGS)</td><td style="text-align: center;">09 - CONTROL THERMOSTAT (SETTINGS)</td></tr> </table>	YES	NO	01 - LICKING	01 - LICKING	02 - VIBRATION	02 - VIBRATION	03 - BUBLING SIGHT	03 - BUBLING SIGHT	04 - NORMAL OIL LEVEL	04 - NORMAL OIL LEVEL	05 - CRANKCASE RESISTENC ACTUING	05 - CRANKCASE RESISTENC ACTUING	06 - NORMAL VOLTAGE	06 - NORMAL VOLTAGE	07 - HIGH PRESSOSTAT, ON/OFF:	07 - HIGH PRESSOSTAT, ON/OFF:	08 - LOW PRESSOSTAT, ON/OFF:	08 - LOW PRESSOSTAT, ON/OFF:	09 - CONTROL THERMOSTAT (SETTINGS)	09 - CONTROL THERMOSTAT (SETTINGS)	<table style="width: 100%; border-collapse: collapse;"> <tr><td style="text-align: center;">YES</td><td style="text-align: center;">NO</td></tr> <tr><td style="text-align: center;">01 - LICKING</td><td style="text-align: center;">01 - LICKING</td></tr> <tr><td style="text-align: center;">02 - VIBRATION</td><td style="text-align: center;">02 - VIBRATION</td></tr> <tr><td style="text-align: center;">03 - BUBLING SIGHT</td><td style="text-align: center;">03 - BUBLING SIGHT</td></tr> <tr><td style="text-align: center;">04 - NORMAL OIL LEVEL</td><td style="text-align: center;">04 - NORMAL OIL LEVEL</td></tr> <tr><td style="text-align: center;">05 - CRANKCASE RESISTENC ACTUING</td><td style="text-align: center;">05 - CRANKCASE RESISTENC ACTUING</td></tr> <tr><td style="text-align: center;">06 - NORMAL VOLTAGE</td><td style="text-align: center;">06 - NORMAL VOLTAGE</td></tr> <tr><td style="text-align: center;">07 - HIGH PRESSOSTAT, ON/OFF:</td><td style="text-align: center;">07 - HIGH PRESSOSTAT, ON/OFF:</td></tr> <tr><td style="text-align: center;">08 - LOW PRESSOSTAT, ON/OFF:</td><td style="text-align: center;">08 - LOW PRESSOSTAT, ON/OFF:</td></tr> </table>	YES	NO	01 - LICKING	01 - LICKING	02 - VIBRATION	02 - VIBRATION	03 - BUBLING SIGHT	03 - BUBLING SIGHT	04 - NORMAL OIL LEVEL	04 - NORMAL OIL LEVEL	05 - CRANKCASE RESISTENC ACTUING	05 - CRANKCASE RESISTENC ACTUING	06 - NORMAL VOLTAGE	06 - NORMAL VOLTAGE	07 - HIGH PRESSOSTAT, ON/OFF:	07 - HIGH PRESSOSTAT, ON/OFF:	08 - LOW PRESSOSTAT, ON/OFF:	08 - LOW PRESSOSTAT, ON/OFF:	<p style="text-align: center;">IMPORTANT</p> <p>1. SCROLL COMPRESSOR MUST BE CLOCK-WISE ONLY, BEFORE STARTING UNIT CHECK PHASE SEQUENCE, FOLLOW MANUAL INSTRUCTIONS</p> <p>2. SCROLL COMPRESSOR CANNOT OPERATE ON VACUUM, OTHERWISE IT WILL HAVE DAMAGE</p> <p>3. IN CASE OF DEFECT DURING START-UP SIGN IT ON SCHEMATIC CIRCUIT OR OBSERVATION ITEM.</p> <p>4. OPERATIONS VALUES NOTES MUST BE DONE AFTER STABILIZATION OF FUNCIONING.</p>
<table style="width: 100%; border-collapse: collapse;"> <tr><td style="text-align: center;">YES</td><td style="text-align: center;">NO</td></tr> <tr><td style="text-align: center;">01 - LICKING</td><td style="text-align: center;">01 - LICKING</td></tr> <tr><td style="text-align: center;">02 - VIBRATION</td><td style="text-align: center;">02 - VIBRATION</td></tr> <tr><td style="text-align: center;">03 - BUBLING SIGHT</td><td style="text-align: center;">03 - BUBLING SIGHT</td></tr> <tr><td style="text-align: center;">04 - NORMAL OIL LEVEL</td><td style="text-align: center;">04 - NORMAL OIL LEVEL</td></tr> <tr><td style="text-align: center;">05 - CRANKCASE RESISTENC ACTUING</td><td style="text-align: center;">05 - CRANKCASE RESISTENC ACTUING</td></tr> <tr><td style="text-align: center;">06 - NORMAL VOLTAGE</td><td style="text-align: center;">06 - NORMAL VOLTAGE</td></tr> <tr><td style="text-align: center;">07 - HIGH PRESSOSTAT, ON/OFF:</td><td style="text-align: center;">07 - HIGH PRESSOSTAT, ON/OFF:</td></tr> <tr><td style="text-align: center;">08 - LOW PRESSOSTAT, ON/OFF:</td><td style="text-align: center;">08 - LOW PRESSOSTAT, ON/OFF:</td></tr> <tr><td style="text-align: center;">09 - CONTROL THERMOSTAT (SETTINGS)</td><td style="text-align: center;">09 - CONTROL THERMOSTAT (SETTINGS)</td></tr> </table>	YES	NO	01 - LICKING	01 - LICKING	02 - VIBRATION	02 - VIBRATION	03 - BUBLING SIGHT	03 - BUBLING SIGHT	04 - NORMAL OIL LEVEL	04 - NORMAL OIL LEVEL	05 - CRANKCASE RESISTENC ACTUING	05 - CRANKCASE RESISTENC ACTUING	06 - NORMAL VOLTAGE	06 - NORMAL VOLTAGE	07 - HIGH PRESSOSTAT, ON/OFF:	07 - HIGH PRESSOSTAT, ON/OFF:	08 - LOW PRESSOSTAT, ON/OFF:	08 - LOW PRESSOSTAT, ON/OFF:	09 - CONTROL THERMOSTAT (SETTINGS)	09 - CONTROL THERMOSTAT (SETTINGS)	<table style="width: 100%; border-collapse: collapse;"> <tr><td style="text-align: center;">YES</td><td style="text-align: center;">NO</td></tr> <tr><td style="text-align: center;">01 - LICKING</td><td style="text-align: center;">01 - LICKING</td></tr> <tr><td style="text-align: center;">02 - VIBRATION</td><td style="text-align: center;">02 - VIBRATION</td></tr> <tr><td style="text-align: center;">03 - BUBLING SIGHT</td><td style="text-align: center;">03 - BUBLING SIGHT</td></tr> <tr><td style="text-align: center;">04 - NORMAL OIL LEVEL</td><td style="text-align: center;">04 - NORMAL OIL LEVEL</td></tr> <tr><td style="text-align: center;">05 - CRANKCASE RESISTENC ACTUING</td><td style="text-align: center;">05 - CRANKCASE RESISTENC ACTUING</td></tr> <tr><td style="text-align: center;">06 - NORMAL VOLTAGE</td><td style="text-align: center;">06 - NORMAL VOLTAGE</td></tr> <tr><td style="text-align: center;">07 - HIGH PRESSOSTAT, ON/OFF:</td><td style="text-align: center;">07 - HIGH PRESSOSTAT, ON/OFF:</td></tr> <tr><td style="text-align: center;">08 - LOW PRESSOSTAT, ON/OFF:</td><td style="text-align: center;">08 - LOW PRESSOSTAT, ON/OFF:</td></tr> </table>	YES	NO	01 - LICKING	01 - LICKING	02 - VIBRATION	02 - VIBRATION	03 - BUBLING SIGHT	03 - BUBLING SIGHT	04 - NORMAL OIL LEVEL	04 - NORMAL OIL LEVEL	05 - CRANKCASE RESISTENC ACTUING	05 - CRANKCASE RESISTENC ACTUING	06 - NORMAL VOLTAGE	06 - NORMAL VOLTAGE	07 - HIGH PRESSOSTAT, ON/OFF:	07 - HIGH PRESSOSTAT, ON/OFF:	08 - LOW PRESSOSTAT, ON/OFF:	08 - LOW PRESSOSTAT, ON/OFF:		
YES	NO																																								
01 - LICKING	01 - LICKING																																								
02 - VIBRATION	02 - VIBRATION																																								
03 - BUBLING SIGHT	03 - BUBLING SIGHT																																								
04 - NORMAL OIL LEVEL	04 - NORMAL OIL LEVEL																																								
05 - CRANKCASE RESISTENC ACTUING	05 - CRANKCASE RESISTENC ACTUING																																								
06 - NORMAL VOLTAGE	06 - NORMAL VOLTAGE																																								
07 - HIGH PRESSOSTAT, ON/OFF:	07 - HIGH PRESSOSTAT, ON/OFF:																																								
08 - LOW PRESSOSTAT, ON/OFF:	08 - LOW PRESSOSTAT, ON/OFF:																																								
09 - CONTROL THERMOSTAT (SETTINGS)	09 - CONTROL THERMOSTAT (SETTINGS)																																								
YES	NO																																								
01 - LICKING	01 - LICKING																																								
02 - VIBRATION	02 - VIBRATION																																								
03 - BUBLING SIGHT	03 - BUBLING SIGHT																																								
04 - NORMAL OIL LEVEL	04 - NORMAL OIL LEVEL																																								
05 - CRANKCASE RESISTENC ACTUING	05 - CRANKCASE RESISTENC ACTUING																																								
06 - NORMAL VOLTAGE	06 - NORMAL VOLTAGE																																								
07 - HIGH PRESSOSTAT, ON/OFF:	07 - HIGH PRESSOSTAT, ON/OFF:																																								
08 - LOW PRESSOSTAT, ON/OFF:	08 - LOW PRESSOSTAT, ON/OFF:																																								

TECHNICS DATA				
PLATE	MODEL	SERIE Nº	CURRENT (AMP.)	OIL LEVEL
COMPRESSOR CIRC.1				
COMPRESSOR CIRC.2				

FUNCTIONING READING						
CIRCUIT	HIGH PRESSURE PSIG.	LOW PRESSURE PSIG.	LIQUID TUBUL. °C	SUCTION TUBUL. °C	SUB-COOLING °C	SUPERHEATING °C
COMPRESSOR CIRC.1						
COMPRESSOR CIRC.2						

AIR EVAPORATOR					
AIR FLOW M ³ /H	RETURN °C		AIR SUPPLY °C		EXTERN °C
	TBS	TBU	TBS	TBU	TBS

AIR CONDENSADER		
AIR FLOW M ³ /H	TBS INLET °C	TBS OUTLET °C

WATER CONDENSADER			
WATER TEMP. °C		WATER PRESSURE ()	
INLET	OUTLET	INLET	OUTLET

CURRENT (AMPS)							
	R	S	T		R	S	T
COMPR. 1				EVAPORADOR			
COMPR. 2				CONDENS. 1			
				CONDENS. 2			
VOLTAGE				VOLTAGE			

NORMAL OPERATION CONDITIONS						
1. OIL SIGHT LEVEL	- NOT INFERIOR TO HALF PSIGHT					
2. LIQUID SIGHT	- CLEAN					
3. RATED VOLTAGE ON PLATE	± 10%					
4. CURRENTS	CHECK TECHNICAL EQUIPMENT CATALOG					
5. TYPICAL VALUES TABLE:						
UNIT MODELS	HIGH PRESSURE		LOW PRESSURE		SUPER °C	SUB °C
	BAR	PSIG	BAR	PSIG		
SRVE/SIVE	14 TO 23.5	200 TO 340	3.8 TO 5.5	54 TO 80	8 TO 12	5 TO 10
SAVE	12.5 TO 16.5	180 TO 240	3.8 TO 5.5	54 TO 80	8 TO 12	5 TO 10

6. PRESSOSTAT ACTUATION:
 LOW PRESSOSTAT - OFF 25±8 PSIG / RESET 80±12 PSIG
 HIGH PRESSOSTAT - (AIR CONDENSER) OFF 385±15 PSIG / RESET 280±20 PSIG
 HIGH PRESSOSTAT - (WATER CONDENSER) OFF 275±15 PSIG / RESET 195±15 PSIG

	MANOMETER LOW/HIGH		PRESSOSTAT HIGH/LOW		SOLENOID VALVE
	THERMOMETER		COMPRESSOR		LIQUID SIGHT
	SERVICE VALVE		DRY FILTER		EXPANSION VALVE

OBS.: WHERE INLET WATER OR AIR TEMPERATURE ON CONDENSER ARE TOO LOW, A ADJUSTMENT FLOW SWITCH MUST BE PLACED TO ENSURE SAFETY OPERATION ON EQUIPMENT

INSTALLER _____	START DATE _____
EMPLOYEE _____	Nº TRANE _____
EMPLOYEE _____	SIGNATURE _____

EQUIPMENT APPLICATION
 COMFORT TELECOIL CPD OTHERS _____

VALVES OR DAMPERS _____

OBSERVATIONS:

V-Operation

Manual stop

It happens when you wish to stop the conditioner for any reason, or at the end of the working period.

1. Put the ON-OFF start switch in the front part of the thermostat in the OFF position. This interrupts the passage of electrical power to the ventilation contactor. When the ventilation contactor is cut out, it turns off the compressors contactors.
2. Keep the circuit breaker or the non-fused molded case switch locked.



ATTENTION

Do not use this procedure to stop the unit when you want to perform services or repairs. To avoid accidents or death due to electrical shock, do the service only with the unit circuit breaker turned off.

3. Stop the operation of all water pumps. Valid for SAVE model.
4. To restart the machine after a temporary stop, restart the water pumps and put the conditioner switch in the ON position.

Stop by the operation control

As the return temperature decreases, the control thermostat turns the equipment compressors off until its complete outage. If there is a temperature increase, the control thermostat turns them on one by one.

Stop by the safety control

Any of the safety controls related ahead may cause the conditioner to stop.

Before rearming them, fix the irregularity analyzing carefully the installation and using the Diagnostics section as a guide.

Never change the adjustment parts of the safety controls, neither put jumps on them for the conditioner to work. Serious damage may occur and cause a very long system outage.

Temporary stop

Sometimes, it is necessary to stop the conditioner for a few days to change the installation or building servicing. In this case, go on as in the manual stop.

The compressors are denominated from left to right when we looking directly at the equipment. Compressor 1 is the lead.

The logic of the control will only enable the operation of the compressors after the supply fan is turned on.



Operation

Protection and safety devices

The pressure controls have automatic rearming and fixed adjustments.

1. Low pressure controls

The low-pressure control is linked to a schrader valve in the suction piping, reading the pressure that is established at that point and it turns off the equipment when there is lack of evaporation of the refrigerant liquid in the evaporator, with the consequent pressure drop. The disarming value is 25 +/- 8 psig and the rearming value is 80 +/- 12 psig. It is automatically rearmed.

2. Limit low-pressure controls

The scroll compressor cannot work in vacuum. Its operation for more than a minute in negative pressure will cause high discharge temperatures, which will warp the aluminum rotors, damaging the compressor irreversibly. This pressure control can never be stopped by a jumper. Two notices put inside the electrical board: "NEVER JUMP" and "ATTENTION: AVOID DAMAGE TO THE

SCROLL COMPRESSOR" teach which are the correct procedures for a safe operation of the compressor. The disarming value is 10 6 3 psig and the rearming value is 35 6 5 psig. Rearming is automatic.

3. High pressure control

The high-pressure control is linked to the discharge piping, to read the pressure that is established in it and it turns the equipment off if the pressure overtakes the adjusted limit. The disarming value is 395 +/- 15 psig for air-condensing machines and 275 +/- 15 psig for water-condensing machines. The rearming value will occur at 280 +/- 20 psig for air-condensing machines and at 195 +/- 15 psig for water-condensing machines. Rearming is automatic.

4. Inside thermostat to the compressor motor

It is a device placed next to the compressor motor winding to protect the compressor motor against too high temperatures caused by

low refrigerant flow (defective motor cooling) or excessive electrical current (due to extreme requirement conditions). Rearming is automatic.

5. Discharge thermostat

It is a bimetallic thermostat placed inside the Copeland compressor at the discharge chamber. It will turn the compressor off when the temperature reaches 145° C, turning it on again when the temperature falls to 60° C.

6. Overload current relay

The overload current relays are installed with the purpose of protecting the evaporator and condenser motors.

7. Non-fused molded case switch with fuses or electromagnetic circuit breaker

It must be installed at the site to protect the Conditioner.

8. Condenser water flow

It is necessary that the "flow-switch" is gauged to open the contacts when the water flow falls to less than 90% of the condenser nominal.

Table 12 - Normal Operation Conditions

1. HIGH PRESSURE - AIR CONDENSING	200 to 340 psig
2. HIGH PRESSURE - WATER CONDENSING	180 to 240 psig
3. LOW PRESSURE	54 to 80 psig
4. OVERHEATING	From 8 to 12 °C
5. UNDERCOOLING	From 5 to 10 °C
6. LIQUID SIGHTGLASS	Refrigerant Flow With no Gas Traces
7. VOLTAGE	Must not exceed +/- 10% of the Board Voltage
8. CURRENT	Must Not Surpass the Board Current

Table 13 - Controls Adjustment

Control	Disarming	Rearming Observations
High Pressure Control	395 +/- 15 psig	280 + / - 20 psig Air-Condensing
High Pressure Control	275 +/- 15 psig	195 + / - 15 psig Water-Condensing
Low Pressure Control	25 + / - 8 psig	80 + / - psig Both
Compressor Discharge Thermostat	145 °C	60 °C Genius
Motor Winding Thermostat	105 °C	82° C Both

Operation

High Pressure Control Valve - Head Master Alco

Specifically developed to keep the proper pressure of the air-cooled condenser during periods of low conditions of external environment.

General

The air-cooled condensers application for operation during the whole year or during low temperatures periods requires some means of control to keep condensing pressures that assure a proper system operation. It is essential that the proper pressure of the refrigerant liquid is controlled to:

1. Keep the liquid subcooling and avoid gas bubbles in the liquid line.
2. Provide an adequate pressure at the admission side of the thermostatic valve to obtain a sufficient drop pressure by means of the valve gate.

Without a proper condensing pressure control, serious consequences like bad cooling and components damage may occur. Alco Head Master control offers an efficient and economical method to solve this usual problem in the industry of air-cooled condensers.

Operation

The pressure control valve (Head Master) is a three-way modulated valve controlled by the high pressure. The loaded cupula makes a constant pressure over the top of the diaphragm. In high temperature environments, the gas derivation that enters in gate B is admitted under the diaphragm where it puts itself against the load pressure of the cupula. The gas pushes the diaphragm up and allows the support disc to close the superior support, preventing the flow of the gate B (discharge gas), while the flow of the gate C does not stand restrictions.

When the room temperature falls, the air-cooled condenser goes by a corresponding decrease in the high pressure. As the high pressure (derivation) falls, it stops putting itself against the cupula load pressure and the diaphragm moves downwards, moving the stem and the support disc towards the lower support.

When the room temperature falls, the air-cooled condenser goes by a corresponding decrease in the high pressure. As the high pressure (derivation) falls, it stops putting itself against the cupula load pressure and the diaphragm moves downwards, moving the stem and the support disc towards the lower support.

Important: This allows that the discharge gas (derivation) is dosed inside the receptor, generating a higher pressure in the discharge of the condenser. The higher pressure in the condenser discharge reduces the flow coming from gate C and makes the level of condensate liquid raise in the condenser.

Figure V-01 - direction of gas inlet on valve

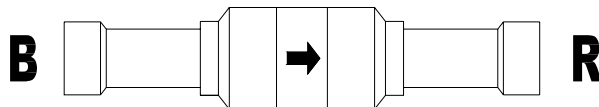
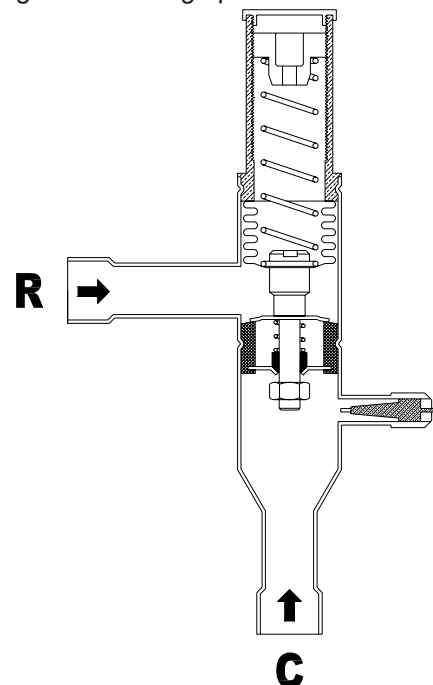

Figure V-02 - High pressure control valve



Operation

As in all high pressure control applications, it is necessary an additional capacity of the liquid recipient to prevent loss of the liquid sealing when the condenser is flooded. The recipient has to be large enough to contain the system's total load. The total load of the system consists of:

A. An operational load - the pounds of refrigerant necessary to operate the system during the climatic conditions of summer (high room temperature).

B. An additional load that equals the number of pounds of refrigerant required to flood the condenser with liquid. The condenser has to be filled with liquid until the point to which a minimum high pressure is created for cold weather conditions (low room temperature). If the outside temperature falls under the design conditions, it will be necessary to use additional refrigerant.

A + B is the total of load necessary for a satisfactory performance of the system during the lowest air room temperature conditions expected. During the summer operation, the recipient must be sized to contain the system's total load safely. **A good cooling takes for granted that the system's total load must not exceed 75% of the capacity of the recipient.**

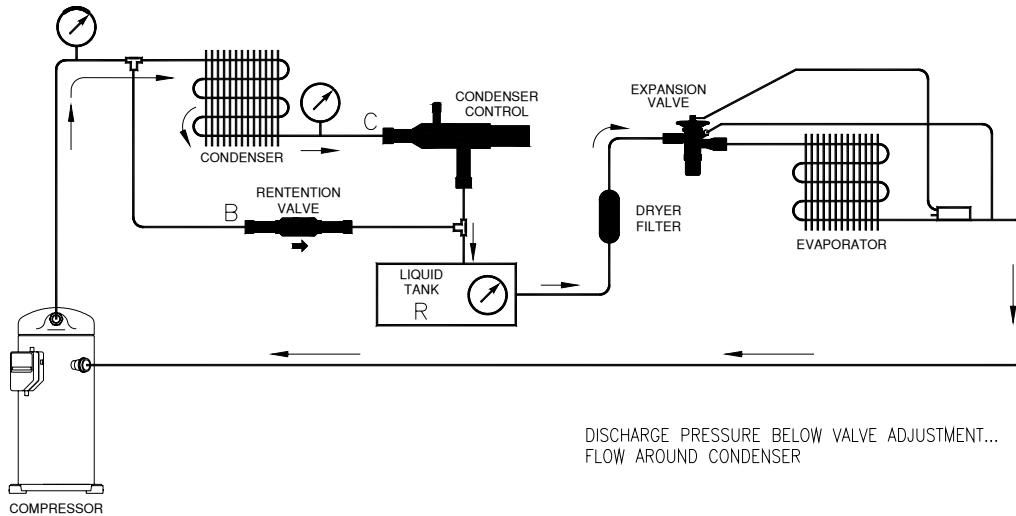

Figure V-03

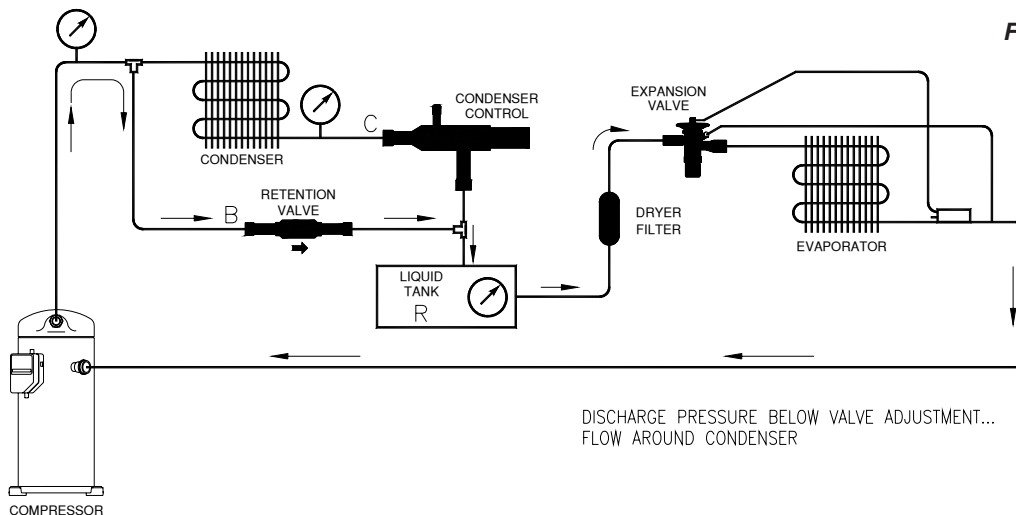

Figure V-04

Operation

Adicional Refrigerant

In most systems, an additional amount of refrigerant will be necessary. It is essential to have enough to completely fill the condenser for a lower room temperature condition. To determine accurately the amount of additional refrigerant load, take the total length of the condenser piping in feet and multiply by the number of pounds of refrigerant per feet for a certain size of piping. Table on the left shows the refrigerant liquid per feet for the winter lowest temperature to be found.

Instructions

Unit adjustment with pressure control valve Head Master. Alco's Head pressure control - series HP 5, HP 8 and HP 14.

- Make the adjustment in a hot day so that the pressure control valve does not work while we are making the adjustment.

- This checking is done by gauging the temperature of the inlet liquid (C) and of the outlet for the tank of liquid (R). The difference should be less than 1o C.

When the valve works, the difference from the inlet liquid (C) to the outlet liquid tank (R) is between 5 and 10o C.

In field, a 5 TR's machine which has a 3,5K g load, received about 8,0 Kg, that is, when we have this kind of valve, the refrigerant load can even double due to the load the remains in the recipient.

Table V-01 - Adicional Refrigerant

Refrigerant	Refrigerant pounds per feet											
	Dimensions of condenser tube											
	3/8"				1/2"				5/8"			
	Room Tem perature °F											
	+ 40°	0°	-20°	-40°	+ 40°	0°	-20°	-40°	+ 40°	0°	-20°	-40°
R12	0,055	0,058	0,060	0,061	0,102	0,107	0,110	0,112	0,163	0,172	0,175	0,179
R407	0,051	0,054	0,550	0,056	0,094	0,094	0,102	0,104	0,150	0,159	0,163	0,167
R502	0,053	0,056	0,580	0,059	0,098	0,098	0,107	0,109	0,157	0,166	0,171	0,175

VI-Maintenance

Periodic Preventive

Perform all inspections and maintenance services in recommended intervals, this will lengthen the equipment working life and reduce the possibility of equipment failures.

Use the “Operation Data Reading Sheet” to record monthly operation conditions for this unit. The operation data sheet can be a valuable diagnostics tool for technical assistance staff. The operator can often foresee and prevent problem situations before they become serious. If unit is not working properly, see the Diagnostics **Section**.

1. Monthly Maintenance

Run the equipment for about 30 minutes and with the system stabilized, check operation conditions by means of the following procedures:

- Check permanent air filters whenever required. Throw-away filters should be replaced once they are saturated.
- Check fan belt tension, alignment and condition.
- Check fan scroll.
- Retighten all terminal screws.
- Clean evaporator tray, hose and condensed water grate.
- Check the liquid line sightglass. Test for leaks and correct them, if required. See item “Checking Operation Conditions”.
- If operation conditions and the liquid sightglass indicate no gas, measure the system’s superheating and subcooling. See item “System Superheating” and “System Subcooling”.

- If running conditions indicate overload, slowly (in order to minimize oil losses) remove refrigerant through the liquid line Schrader service valve.

 **WARNING**

In order to avoid accidents by freezing, avoid skin contact with refrigerant.

- Inspect the system to detect abnormal conditions. Use the reading sheet to record the unit’s conditions. A completed reading sheet is a valuable tool for technical assistance staff.

2. Quarterly maintenance

- Perform all monthly maintenance services.
- Check bearing and pulley locking setscrews for proper tightness.
- Clean condenser whenever required.
- Clean evaporator whenever required.
- Check and write fan motor and compressor service belt tension.
- Test security controls.
- Check and write down dry bulb and wet bulb temperatures at evaporator outlet and inlet.
- Check suction and discharge pressure with the manifold.
- Measure and record the system’s superheating.
- Measure and record the system’s subcooling.

3. Yearly Maintenance

- Perform all recommended monthly and quarterly maintenance services.
- Have a qualified technician check setting and running of each control and inspect and replace, if required, contactors or controls.
- Remove the cabinet panels and remove rust points.
- Replace faulty heat insulation and seals.
- Retouch external and internal painting, if required.
- Remove rust.
- Inspect condenser tubes and clean, if required.
- Inspect expansion valve bulb for cleaning. The bulb should have excellent contact with the suction line and be properly insulated.
- Measure electrical insulation of compressor motor.

Maintenance Procedures

This section describes maintenance procedures that should be performed as part of a normal unit maintenance schedule.

Preventive Maintenance

Air Filters

Permanent and washable filters supplied with the conditioners should be washed in a lukewarm water and neutral detergent bath. Filters should be brushed while in the bath, rinsed in fresh water and blown through with compressed air.

Figure VI-01 - Pulley Alignment

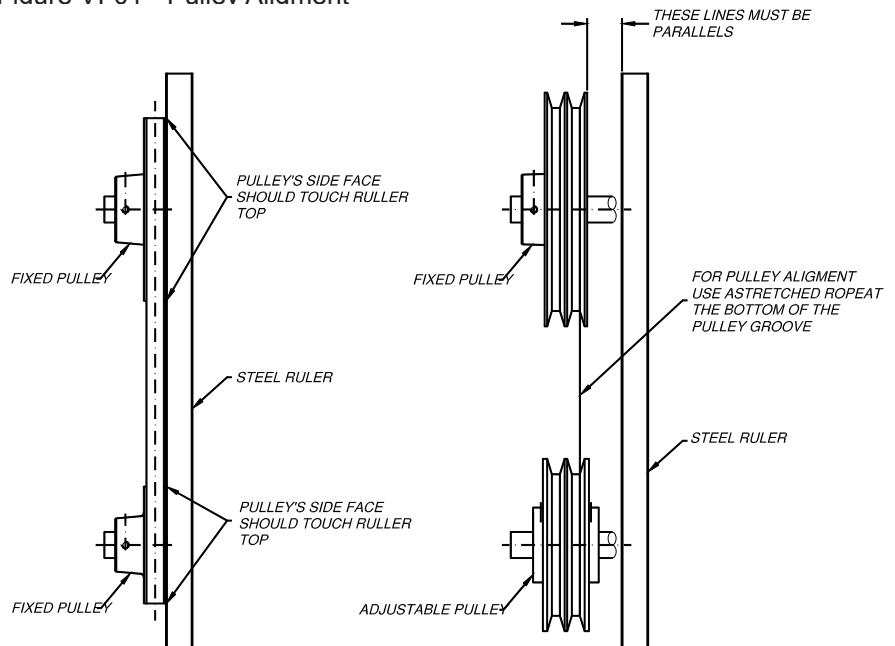

Throw-away filters should be replaced. Do not start the unit without the filters.

Pouley and belts

The pulley's right alignment and operation must be verified.

1. Turn manually pulleys to check if they freely move.
2. Check motor and fans axis . They must be parallel and referencing each other.
3. Check if the pulleys of fan and motor are aligned. In case of dife-rent lenth pulleys, align the central part as shown on below figure

4. After alignment apply thread-locker Loctite 242 and tighten the internal screws of the pulleys using torquemeter, torque specification according to the table below:

Thread	Torque
Diameter 1/4"	10 N.m.
Diameter M6	
Diameter 5/16"	18 N.m

5. Check adequate belt tensioning to provide a longer useful life to motor and fan bearings.

Maintenance Procedures

Belt Tensioning Measurement

To perform belt tensioning measurement, you will need a tension gauge as shown in figure above. Correct deflection is determined by dividing the distance between pulleys /64 (in inches).

In case you do not have the above tension gauge for checking belt tensioning, it should be pressed with the thumb and show an arrow of more or less 10 mm. If you need to replace it by a new one, tension them and keep them running for several hours until they fit into the pulley grooves, then tension them again.

Liquid Sightglass

When it is bubbling, it may indicate one or more of the following problems:

- a. No refrigerant;
- b. Blocked drier filter;
- c. Expansion valve too open;
- d. Low subcooling;

- e. Incondensable present.

When liquid is yellowish, it indicates the presence of residual humidity in the refrigerant circuit. Under normal operation, the sightglass should have no bubbling and show a green coloration, which indicates that the refrigerating circuit has the correct refrigerant load and is dehydrated.

Air Condenser

It should always be cleaned with a soft brush and compressed air, or water at low pressure applied in the opposite direction to normal airflow. Move the hose vertically and set its pressure so that it does not deform the fins.

Figure VI-02 - Belt Tension Settings

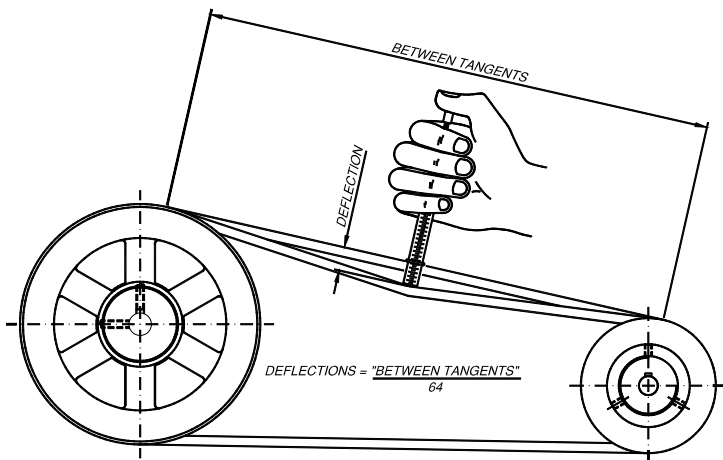
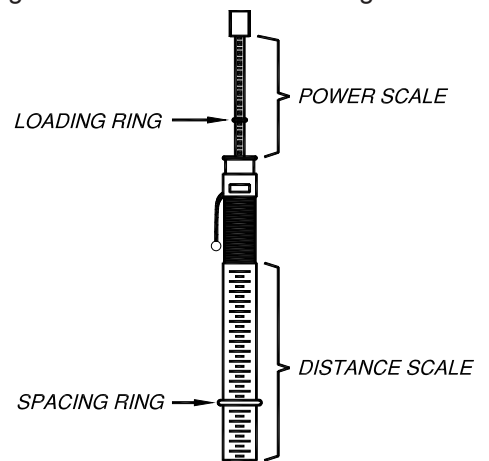

Figure VI-03 - Belt Tension Gauge



Maintenance Procedures



ATTENTION

Do not wrinkle fins when cleaning.

Water Condenser Cleaning

Available water for condensation often contains minerals that accumulate on the condenser tube walls, forming incrustation layers. The layer accumulation speed will be increased by high condensation temperatures and by water with a high mineral content. A decreased water flow, a slight temperature difference between water inlet and outlet and an abnormally high condensation temperature indicate sediment layer formation in the condenser water pipes.

In order to maintain maximum efficiency, condenser should remain free of sediments. Even a very thin layer on the tube surfaces may substantially decrease the condenser heat transfer capacity. The two methods for cleaning condenser tubes are mechanical and chemical.

Mechanical cleaning

The mechanical cleaning method is used to remove iodine or other incrustated material in the condenser tubes.

- a.** Close the condenser water supply;
- b.** Undo the tubing connections;
- c.** Remove condenser headers;
- d.** Apply an internal brush through the pipes to release the iodine;
- e.** Wash tubes with a water jet.

Chemical Cleaning

Chemical cleaning is the most proper and effective means for removing deposits from tubes. In this treatment, deposits are dissolved and charged by a chemical bath circulation. Condenser is made up by copper, steel and cast iron. With this information, any company devoted to water treatment can recommend a proper chemical product for this purpose. If it is not possible to rely on a water treatment service, refer to a

chemical product supply company. Figure below shows the typical installation for chemical cleaning. All materials used in the external circulation system, cleaning material quantity, cleaning period duration and any safety precautions required for handling cleaning agents used to perform the service should be approved by the chemical product Supply Company.

Water Treatment

The use untreated or improperly treated water may result in the formation of incrustations, erosion, corrosion, algae and slime. It is recommended that the services of a qualified specialist be hired for treating water in order to determine which treatment, if required, should be performed.

Trane does not accept any liability for any equipment failure resulting from the use of water that is untreated or treated improperly.

Figure VI-04 - Condenser Cleaning

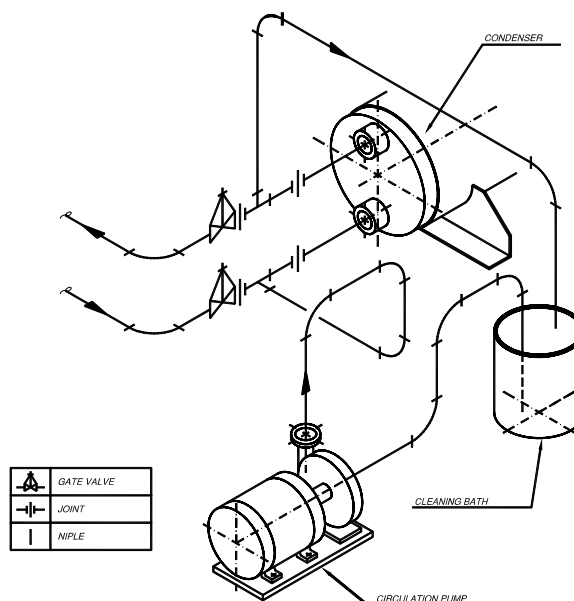

Maintenance Procedures

Corrective maintenance

It will be easier to find the cause of system malfunctioning by identifying the control that opened the circuit. Confirm it by checking for no continuity through the indicated control. Make sure the control is correctly set and running properly.



ATTENTION

Never turn the equipment on without first removing the cause of the failure presented.



ATTENTION

Always use a pressure-regulating valve between the nitrogen cylinder and the manometer set. Never, under any circumstance, fail to use it.

Leakage tests with nitrogen

The leakage test should be performed after effecting interlock piping installation of split units, whenever the liquid sightglass shows bubbling or after the machine undergoes repairs in the cooling system. Use refrigerant as a testing element for leak detection and dry nitrogen for reaching the testing pressure.

Procedures

- Install the pressure-regulating valve in the nitrogen cylinder.
- Inject this gas into the system gradually, until reaching a maximum pressure of 200 psig.

Figure VI-05 - Refrigeration Cycle

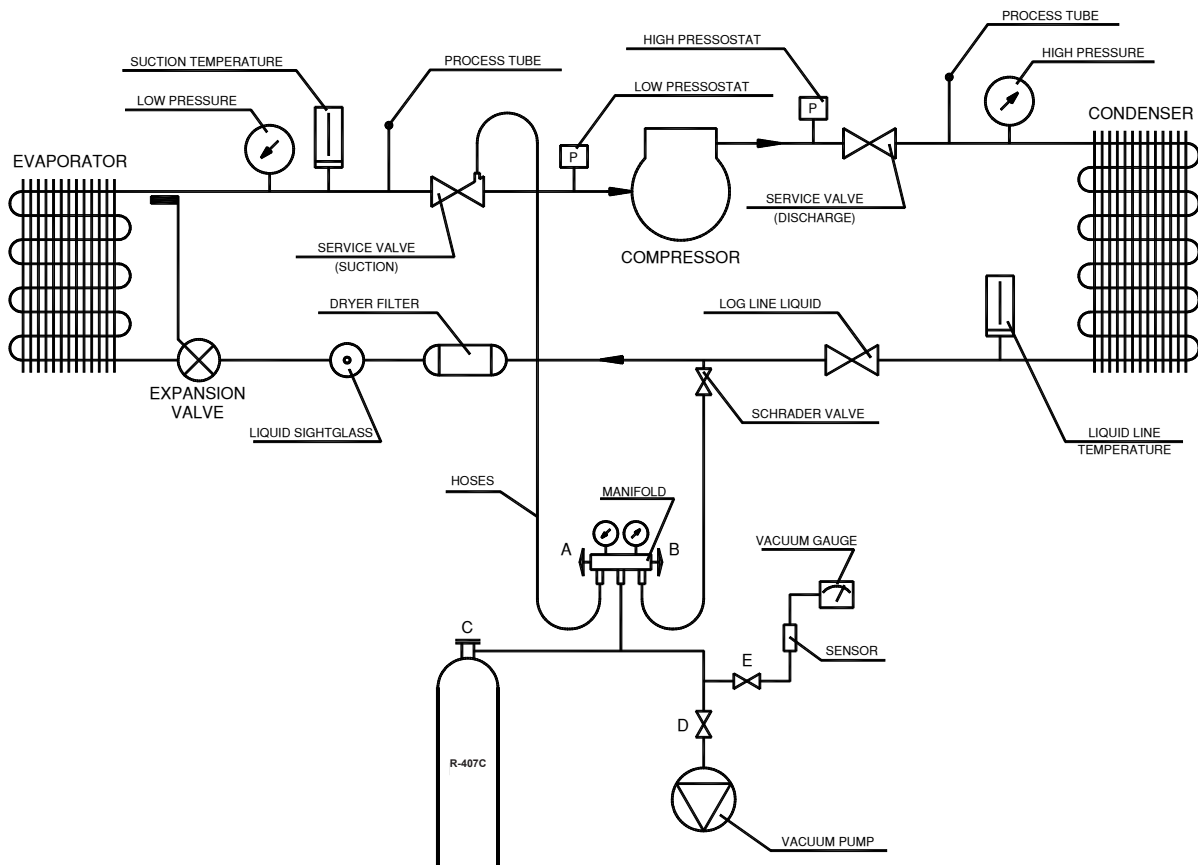

Maintenance Procedures

- Check for leaks in all welding points and circuit connections and flanges with soap foam that forms bubbles in the defect spot.
- Test is with R-407C is performed by injecting a pressure of 14 psig with R-407C prior to placing nitrogen pressure. Check for leaks with an electronic detector or halogen lamp.
- In case you detect any leak, relieve pressure, make the repair and perform a new test to make sure leaking has been removed.

⚠ ATTENTION

Under no circumstance use oxygen or acetylene instead of dry nitrogen to test for leaks; it may cause a violent explosion.

Emptying

- Emptying is required for removing water steam and non-condensable gases from the system.
 - Use a rotating high vacuum pump.
 - Install a manometer-manifold set indicated in refrigeration cycle figure . Open stopcocks A-B-S-E / Close stopcock C.
 - A minimum vacuum time of one hour is recommended for making the first reading. Emptying will only be completed if final vacuum remains between 250 and 500 microns.
- As a release test, the pump stopcock must be closed for 5 minutes and vacuum should not rise more than 100 microns.

Refrigerant load

In order to achieve a precise refrigerant load, use a scale to weigh refrigerant in a cylinder or a graded bottle. Quantity depends on the unit model and tubing dimensions. Before placing refrigerant, make sure equipment is not in vacuum and has no leaks.

Liquid Refrigerant Load

The refrigerant load in the form of liquid is performed with the compressor stopped, through the liquid line Schrader valve. Control refrigerant inlet with the manometer set stopcock. The initial system load should be effected with liquid refrigerant. Open stopcocks A-D-E - *Place refrigerant with cylinder inverted.

- After the estimated refrigerant load is in, close the stopcocks C - B. Start the unit and watch pressures and temperatures to make sure it is running normally.

⚠ ATTENTION

Weigh the refrigerant cylinder before and after the load.

Steam Refrigerant Load

The refrigerant load in the form of steam is performed through the section service valve with the compressor running. This system is normally used for refrigerant part-loads.

- Open stopcocks C-A. Close stopcocks B-D-E.

The refrigerant load will only be correct when high, low, superheating and subcooling pressures are within the normal operation range.

Subcooling Calculation

Subcooling is the difference between saturated condensation temperature (SCDT) and liquid line temperature (LLT).

- Take the saturated condensation temperature matching pressure indicated by the high manometer.
- Take the liquid line temperature indicated by the thermocouple, before the filter dryer.

-Calculate the difference
 $SUB = SCDT - TLL$

- The result should indicate 5 to 10 °C;

- Place the estimated refrigerant cylinder, close the stopcocks C - A.

Superheating Calculation

Superheating is the difference between the suction line temperature (SLT) and saturated evaporation temperature (SEV T).

- Take the suction temperature indicated by the thermocouple at about ten centimeters from the compressor.
- Take the saturated evaporation temperature matching the pressure indicated by the low manometer;
- Calculate the difference:

$$SUP = SLT - SEV T$$

The result should indicate between 8 and 12 °C. In case found superheating and subcooling temperatures do not match the established range, correct them.

⚠ CAUTION

Do not run the compressor with any amount of refrigerant present in the circuit. Damages to the system may occur.

⚠ ATTENTION

Never apply a flame to the cylinder to increase its pressure. Uncontrolled heat may cause excessive pressures and explosion, resulting in body injuries, death and damages to equipment.

⚠ ATTENTION

Do not allow refrigerant contact with skin. If it happens, treat the wound as if it were a sore caused by freezing or congealing. Slowly warm the affected area with warm water.

⚠ CAUTION

Do not allow liquid refrigerant into the suction line. Excessive liquid may damage the compressor.



Maintenance Procedures

R-407C

Notes:

1. By varying 1 °C in subcooling, superheating varies 3 °C.
2. The thermostatic expansion valve closes by rotating the shat clockwise; anticlockwise it opens.

Tab. VI-02 - Superheating and subcooling settings.

Activity	Overheating		Sub cooling	
	Increases	Reduces	Increases	Reduces
Open expansion valve		X		X
Lock expansion valve	X		X	
Put R-407c refrigerant		X	X	
Remove R-407c refrigerant	X			X

Tab. VI-03 - From Pressure (PSIG) x Temperature (°F) To R-407C.

PSIG	Sat. Liq. (°C)	Sat Ste. (°C)	PSIG	Sat. Liq. (°C)	Sat Ste. (°C)
30	-17,2	-10,6	165	27,2	32,2
32	-16,1	-9,4	170	27,8	33,3
34	-15,0	-8,3	175	28,9	34,4
36	-13,9	-7,2	180	30,0	35,6
38	-12,8	-6,1	185	31,1	36,1
40	-11,7	-5,0	190	32,2	37,2
42	-10,6	-3,9	195	32,8	38,3
44	-9,4	-3,3	200	33,9	38,9
46	-8,9	-2,2	205	35,0	40,0
48	-7,8	-1,1	210	35,6	40,6
50	-6,7	-0,6	215	36,7	41,7
52	-6,1	0,6	220	37,2	42,2
54	-5,0	1,7	225	38,3	43,3
56	-4,4	2,2	230	38,9	43,9
58	-3,3	2,8	235	40,0	45,0
60	-2,8	3,9	240	40,6	45,6
62	-1,7	4,4	245	41,7	46,7
64	-1,1	5,6	250	42,2	47,2
66	0,0	6,1	255	43,3	47,8
68	0,6	6,7	260	43,9	48,9
70	1,1	7,8	265	44,4	49,4
75	3,3	9,4	270	45,6	50,0
80	5,0	11,1	275	46,1	50,6
85	6,7	12,8	280	46,7	51,7
90	7,8	13,9	285	47,8	52,2
95	9,4	15,6	290	48,3	52,8
100	11,1	17,2	295	48,9	53,3
105	12,8	18,3	300	49,4	53,9
110	13,9	20,0	310	51,1	55,6
115	15,0	21,1	320	52,2	56,7
120	16,7	22,2	330	53,9	57,8
125	17,8	23,9	340	55,0	58,9
130	18,9	25,0	350	56,1	60,6
135	20,6	26,1	360	57,2	61,7
140	21,7	27,2	370	58,9	62,8
145	22,8	28,3	380	60,0	63,9
150	23,9	29,4	390	61,1	65,0
155	25,0	30,6	400	62,2	66,1
160	26,1	31,7	425	65,0	68,3

Maintenance Procedures

New compressor installation

The compressor may basically present two kinds of problems: mechanical or electrical. In both cases, compressor should be replaced, however, always remember that it is not enough to replace it, always try to locate and remove the cause(s) of the failure.

MECHANICAL BREAK

If compressor has no service valves, transfer refrigerant to an appropriate cylinder, perform pressurization test (maximum 200 psig to protect low pressure control), make a new vacuum, refrigerant load and restart with all readings. Correct installation where it may have impaired equipment, releasing it for running and always maintain a follow-up performed by a qualified company. If compressor has service valves, refrigerant may be kept in the circuit.

- 1.1.** Turn the compressor power main off and remove electrical cables (mark them);
- 1.2.** Close the compressor suction and discharge valves;
- 1.3.** Disconnect the compressor service valves;
- 1.4.** Remove the compressor;
- 1.5.** Install the new compressor;
- 1.6.** Install the power main and pressure control cruppers;
- 1.7.** Empty the compressor;
- 1.8.** Open the compressor valves.

Motor burning

Motor burning implies the formation of acids and settling of oxides and sediments on parts of the circuit, therefore the need to replace refrigerant and oil and clean the whole

circuit by placing antiacid HH filter dryers, in the suction and liquid line. In this case the following should be done:

2.1. Collect all refrigerant in a cylinder and send it for recycling by manufacturer, or perform its recycling with your own equipment;

NEVER RELEASE GAS INTO THE ENVIRONMENT

- 2.2.** Remove the compressor;
- 2.3.** Remove the filter dryer;
- 2.4.** Install the proper filter in the compressor suction line and change the one in the liquid line;
- 2.5.** Install the new or recovered compressor, empty and load the system;
- 2.6.** Check the contactor. Contacts should be cleaned or replaced;
- 2.7.** Start the equipment and follow its operation;
- 2.8.** Check the pressure loss through the suction filter. If pressure loss exceeds the one recommended by manufacturer, the filter should be replaced;
- 2.9.** After running for 24 hours, oil should be analyzed;
- 2.10.** Change oil and filters every 48 hours until obtaining acid-free oil;
- 2.11.** Remove the suction filter. When cleaning a two-compressor circuit, it will be necessary to change the burned compressor oil and of its pair two.



VII-Tools and Equipment

Required Tools

- Set of 7/16 to 1 1/4" pipe wrenches;
- Torque meter with scale up to 180 ft/lbf;
- 6" to 12" adjustable screw wrench;
- 4" cock spanner;
- Complete set of ;
- Screwdriver set;
- Pliers set: combination cutting pliers, cutting pliers, pipe wrench, and wire stripper;
- Tube flange set;
- Ratchet-spanner for refrigeration;
- Set of 1/4 to 1/ 1/4" fixed wrenches;
- Set of 1/4 to 9/16 star wrenches.

Required Equipment

- Pressure regulator for nitrogen;
- 5 cfm vacuum pump;
- Electronic vacuum meter;
- 500-volt Megohmmeter with 0 to 1000 megohms scale;
- Electronic leak detector;
- Ammeter pliers;
- Complete manifold;
- Electronic thermometer;
- R-407C refrigerant and Trane 48 oil;
- Oxyacetylene welding equipment;
- Freon R-407C pressure temperature table;
- Cooling gas transfer or recovery valve;
- Anemometer;
- Psychrometer;
- Sheave remover;
- Manual oil pump.

VIII-Diagnostics



ATTENTION

Turn the power off and wait for each rotating equipment to stop before servicing, inspecting and testing the unit

Troubleshooting

System Check

Before using the equipment irregularities tables described ahead, do the following analyses:

1. Measure the Voltage in the compressor and fans terminals while the unit is running. The Voltage must be within the motor range indicated in the plate. Its unbalancing must be lower than 2%.
2. Check if all the wirings and connections are in good condition and well attached. The electrical diagram is glued on the switchboard cover.
3. Check if all the fuses are properly installed and sized.
4. Check if all the air filters and coils are clean and check the airflow for obstructions.
5. If the unit is not working, set the control switch to OFF. Allow the internal compressor sensors to cool down.
6. Check the thermostat settings.
7. Check if the Fans are turning in the right direction.
8. Inspect the attachment of the air ducts.
9. Inspect the airflow outlet controls (if there are any).
10. Measure the return of air.

Operation Procedures

Install the high and low pressure gauges on the schrader valves in the liquid and suction lines.

When the unit stabilizes (after operating for 15 minutes at full load), take down notes on the suction and head pressures. Failures in the system, such as lack of air, restriction in the filter drier, expansion valve malfunction, cause the pressures to go out of their ranges.

Unbalanced Voltage

Excessive unbalancing among the phases of a three-phase system will cause an overheating in the motors and possible failures.

The maximum unbalance permitted is 2%.

Voltage Unbalance can be defined as 100 times the maximum variation of the three voltages (three phases) in relation with the arithmetic average of those (without taking the signal into account), divided by the arithmetic average.

Example

If the three voltages measured in a line are 221 volts, 230 volts and 227 volts, their arithmetic average will be: $(221 + 230 + 227) / 3 = 226$ volts. The unbalance percentage is: $100 \times (226 - 221) / 226 = 2.2\%$. The result indicates there is an unbalance above the maximum permitted in 2%. This unbalance may result in a current unbalancing of 20%, having as a result an increase in the motor's winding's temperature and a decrease in the useful life of the motor.



IX-Troubleshooting

A. THE CONDENSER FAN DOES NOT START

Symptoms	Possible Cause	Procedure
1. The voltmeter does not read supply voltage.	1. No power.	1. Check the power supply.
2. The voltmeter does not read supply voltage for the contactors.	2. The non-fused molded case switch is off.	2. Turn the non-fused molded case switch on.
3. The voltmeter reads voltage before the fuses, but not after them.	3. Burnt out fuse.	3. Replace fuses. Check motor load.
4. The voltmeter reads low voltage.	4. Low voltage.	4. Contact the Power Company.
5. There is voltage in the motor terminals, but it does not start.	5. Burnt out motor.	5. Replace it.
6. Start contactor does not close.	6. Check the controls and if the contactor coil is burnt out.	6. Repair or replace it.
7. Contactor does not energize.	7. Overload relay contact is open.	7. Reset the overload relay.

Troubleshooting

B. COMPRESSOR DOES NOT START

Symptoms	Possible Cause	Procedure
1. Electrical circuit test reveals there is no voltage on the motor start switch line side.	1. No power.	1. Check the power supply.
2. Electrical circuit test reveals there is no voltage on the motor start switch line side.	2. Non-fused molded case switch is open.	2. Find out why the non-fused molded case switch was opened. If the system is in working conditions, close the switch.
3. Electrical circuit test reveals there is voltage on line side, but not on the fuse load side.	3. Burnt out fuse.	3. Replace fuses. Check motor load.
4. The voltmeter reads low voltage.	4. Low voltage.	4. The use of the voltmeter is already installed in the system. Call the Power Company.
5. There is voltage in the motor's terminals, but it does not start.	5. Burnt out motor.	5. Repair or replace it.
6. Start switch inoperative.	6. Test to check there are no burnt out coils or broken contacts.	6. Repair or replace it.
7. The start switch's coil does not receive power.	7. Control circuit is open. 7.1. High pressure control. 7.2. Low pressure control. 7.3. Limit pressure control. 7.4. Motor protections 7.5. Interlocking circuit open. 7.6. Turned off by the ambient thermostat	7. Find out what control turned it off and the cause.
8. The compressor does not run.	8. The compressor is stuck or damaged.	8. Repair or replace the compressor.
9. The low pressure control contacts are open.	9. Suction pressure is below the control point of the pressure switch.	9. Check for loss of refrigerant, repair the leak and reload.
10. The high pressure control contacts open. High pressure above normal.	10. Head pressure above the high pressure control point.	10. See problem G.
11. Start switch circuit does not set.	11. Overload relays contacts are open.	11. Rearm the relay, the RCM and check for the cause.
12. The system does not start.	12. Contacts of the flow switch are open.	12. Restore the water flow and check the flow switch operation. Check the switches.



Troubleshooting

C. COMPRESSOR RUNS INTERMITTENTLY

Symptoms	Possible Cause	Procedure
1. Normal operation, except for frequent stops and starts	1. Intermittent contact in the control circuit (electrical bad contact).	1. Repair or replace the defective control.
2. Same as above.	2. Low pressure control's differential is too tight.	2. Adjust the differential for the normal running conditions.
3. The solenoid valve hisses when closed. There is also change in the refrigerant line temperature through the valve.	3. Leaking in the liquid line's solenoid valve.	3. Repair or replace it.
4. Normal operation except for too frequent stops and starts by Low Pressure. Bubbles in the sightglass.	4. It lacks refrigerant.	4. Repair the refrigerant leak and reload.
5. Suction pressure too low and ice forming in the drier.	5. Drier in the liquid line is clogged.	5. Replace the drier core

D. COMPRESSOR RUNS CONTINUOUSLY

Symptoms	Possible Cause	Procedure
1. High temperature in the conditioned area	1. Excessive load.	1. Check for outdoor air infiltration. Check the area's thermal insulation for inadequacy.
2. Low temperature in the conditioned area.	2. Thermostat is set to a too low temperature.	2. Readjust or replace it.
3. Low temperature in the conditioned space.	3. Start switch contacts jammed.	3. Repair or replace the contactor.
4. Conditioned site is too cold.	4. Solenoid valve in the liquid line is open and stuck.	4. Repair or replace the valve.

Troubleshooting

E. COMPRESSOR WITH OIL LEVEL TOO LOW

Symptoms	Possible Cause	Procedure
1. Oil level is too low	1. Insufficient oil load.	1. Add a sufficient amount of the compressor appropriate oil.
2. Oil level drops gradually.	2. Filter drier clogged.	2. Replace the filter drier.
3. Suction excessively cold.	3. Expansion valve bulb is loose (bad thermal contact).	3. Produce a good contact between the remote bulb and the suction line.
4. Same as previous item and noisy operation of the compressor.	4. Return of liquid to the compressor.	4. Reset the superheat, subcooling, or check the remote bulb contact of the expansion valve.
5. Starts and stops excessively frequent.	5. The compressor starts and stops frequently.	5. See related problems in problem "B".

F. COMPRESSOR IS NOISY

Symptoms	Possible Cause	Procedure
1. Rattling noises.	1. It lacks oil.	1. Add oil.
2. Excessive noise.	2. Compressor internal parts broken.	2. Replace the compressor.
3. Excessively cold suction line.	3. Liquid is returning to the compressor.	3. Check and adjust the superheating. The valve may be too big or the remote bulb may be loose in the suction line.
4. Excessively cold suction line. The compressor vibrates.	4. Expansion valve stuck in the open position.	4. Repair or replace



Troubleshooting

G. SYSTEM HAS DEFICIENT THROUGHPUT

Symptoms	Possible Cause	Procedure
1. Expansion valve hisses.	1. Bubbles in the liquid.	1. Add refrigerant.
2. Change of temperature in the refrigerant line through the filter drier or the solenoid blocking valve.	2. Filter drier or the solenoid blocking valve is clogged.	2. Clean or replace it.
3. Short cycling.	3. Expansion valve is stuck or clogged.	3. Repair or replace the expansion valve.
4. Superheating is too high.	4. Excessive pressure drop in the evaporator.	4. Check superheating and readjust the expansion valve.
5. Supply air temperature too high or too low.	5. Inadequate superheating.	5. Check the superheating. Adjust the expansion valve.
6. Reduced airflow. Evaporation temperature below zero.	6. Clogged air filters.	6. Clean or replace them.

Troubleshooting

H. HEAD PRESSURE TOO HIGH

Symptoms	Possible Cause	Procedure
1. High air temperature through the condenser.	1. Small airflow through the condenser.	1. Readjust the flow. Check for obstructions.
2. Air coming out of the condenser excessively cold. Small rise in temperature through the condenser.	2. Dirty condenser fins.	2. Clean the fins.
3. Air coming out of the condenser in high temperature.	3. Malfunction in the condenser's fans.	3. Check the motors of the condenser fans.
4. Condenser exceptionally hot and excessive head pressure.	4. Air or non-condensable gases in the system.	4. Transfer refrigerant for recycling. Produce new vacuum and load the system.
5. Same as above.	5. Excessive refrigerant load.	5. Gradually remove the excess refrigerant. Normal subcooling is from 6 to 10 oC.
6. Dirty tubes in the "Shell and Tube" condenser.	6. Water is coming out too cold from condenser. Small rise in temperature through the condenser.	6. Clean condenser tubes.
7. Cooling tower malfunction.	7. Water enters the condenser at high temperature.	7. Check the tower's fan motor, the starting device and the thermostat.



Troubleshooting

I. HEAD PRESSURE TOO LOW

Symptoms	Possible Cause	Procedure
1. Small rise in water temperature through the condenser.	1. Excessive water flow through the condenser	1. Readjust the flow and the project's pressure drop.
2. The same for air.	2. Excessive airflow through the condenser.	2. Readjust the flow and the project's pressure drop.
3. Bubbles in the sightglass.	3. Lacking refrigerant.	3. Repair leak and reload.
4. Temperature of air entering the condenser is too low.	4. Outdoor air temperature is too cold.	4. Install an automatic pressure regulator.
5. Compressor's discharge or suction valves broken or leaking.	5. Suction pressure rises more rapidly than 5 psig per minute after a stop.	5. Remove head, check the valves and replace the ones that are not operating properly.

J. SUCTION PRESSURE TOO HIGH

Symptoms	Possible Cause	Procedure
1. Abnormally cold suction line. Liquid returns to compressor.	1. Excessive flow in the expansion valve.	1. Regulate and adjust the expansion valve superheating and check if the bulb is properly attached to the suction line.
2. Same as above.	2. Expansion valve is stuck in the open position.	2. Repair or replace the expansion valve.
3. Excess load in the equipment.	3. The compressor runs continuously.	3.
4. Expansion valve is stuck.	4. Suction line abnormally cold. Liquid is returning to the compressor.	4. Repair or replace the valve.
5. Suction valves broken in the compressor.	5. Compressor is noisy.	5. Remove head, check the valves and replace the ones that are inoperative.
6. Excessive flow in the expansion valve.	6. Suction line abnormally cold. Liquid is returning to the compressor.	6. Regulate the superheating setting of the expansion valve and check if the bulb is properly attached to the suction line.

Troubleshooting

K. SUCTION PRESSURE TOO LOW

Symptoms	Possible Cause	Procedure
1. Bubbles in the sightglass.	1. Lacking refrigerant.	1. Repair the leak and reload.
2. Compressor enters short cycling.	2. Poor thermal load in the chiller.	2. See item B.
3. Change in temperature in the liquid line through the drier or the solenoid blocking valve.	3. Liquid line drier clogged or restriction in the solenoid valve.	3. Replace the filter drier or the solenoid valve.
4. There is no refrigerant flow through the valve.	4. The expansion valve's remote bulb has lost its load.	4. Replace the expansion valve.
5. Capacity loss.	5. Expansion valve is obstructed.	5. Clean the valve and replace it if required.
6. Conditioned ambient is too cold.	6. RCM's potentiometer is set too low.	6. Adjust or replace it if required.
7. Superheating too high.	7. Excessive drop in pressure through the chiller.	7. Readjust the superheating.
8. Low airflow.	8. Filter is clogged.	8. Clean or replace the filter.

L. SCROLL COMPRESSOR EXCESSIVE CONSUMPTION

Symptoms	Possible Cause	Procedure
1. High temperature in the conditioned area.	1. It is operating with excessive thermal load.	1. Check for area air infiltrations and thermal insulation.
2. Excessive consumption.	2. It is operating with low voltage.	2. Ensure the voltage is within the utilization range. In case it is not, call the Power Company.
3. Excessive consumption.	3. Overload relay disarms.	3. Check operation. Replace relay if required.



Troubleshooting

M. SCROLL COMPRESSOR'S LOW CONSUMPTION

Symptoms	Possible Cause	Procedure
1. Little change in the high and low pressures.	1. The compressor is turning counterclockwise.	1. Swap two phases.
2. Suction pressure is extremely low.	2. Check for restrictions and lack of refrigerant.	2. Eliminate leaks and complete the load. Eliminate restrictions.
3. Compressor does not pump and the suction and head pressures are low. The compressor is correctly phased.	3. Compressor is damaged.	3. Check oil condition and replace compressor.

N. THERMOSTAT'S WINDING OPENS SCROLL COMPRESSOR

Symptoms	Possible Cause	Procedure
1. Compressor vibrates and makes noise.	1. The compressor is turning counterclockwise.	1. Swap two phases in the unit.
2. Suction pressure is low.	2. Lack of gas and motor overheat.	2. Eliminate leaks and load gas.
3. Suction pressure is low.	3. Compressor starts repeatedly, opening the motor's internal thermostat.	3. Same as above.

O. SCROLL COMPRESSOR WITH INCORRECT PHASING

Symptoms	Possible Cause	Procedure
1. Low ampere rating. High and low pressures change little. Rattling sounds. Compressor vibrates excessively.	1. The compressor is turning counterclockwise.	1. Swap two phases.

Troubleshooting

High Pressure Control Valve - Head Master Alco

Symptoms	Possible Cause	Procedure
1. Low high pressure during operation	Valve incapable of choking the C port because: a. foreign material inserted between the C port seat and the disc seat. b. Loss of load of the power element. c. Insufficient system load for winter weather conditions	Artificially raise the peening pressure and apply a light bump in the valve's body to dislodge the foreign material. Replace the valve. In series HP 14 only, replace the power assembly. Add refrigerant according to specific table Replace valve
	Wrong load pressure in the valve for the refrigerant system	Insulate reservoir.
	Reservoir is exposed to low temperature ambient that acts as condenser.	Eliminate obstruction or open valve.
	Hot gas bypass line restricted or disconnected	Replace or repair the compressor or
	The compressor is not pumping or there is an obstruction in the liquid line or the low side is causing too low suction pressure.	remove the obstruction or other cause for the low suction pressure. Replace or repair the motor, belts,
2. The system operates with high head pressure or its cycles operate with interruptions at high pressure.	The condenser fan (or fans) is not working or is turning in the wrong direction.	wiring or fan control, according to the need. Operate the condenser fans
	Fan cycling.	continuously while the system is operating. Modify the manifold, the circuit or
	The drop in pressure through the condenser exceeds the 20 psi permitted, forcing B port to open partially.	replace the condenser as necessary to reduce the drop in pressure to less than 20 psi. Increase the size of the condenser or
	The condenser is undersized or the airflow is restricted or there is a short circuit.	remove the restriction or the short circuit, as needed. Artificially reduce the peening pressure
	B port is slightly open due to the presence of foreign material between the seat and the disk's seat.	below the valve's setpoint and apply a light bump in the valve's body while the system is in operation to dislodge the foreign materials. Replace the valve.
	B Port's seat is damaged due to the presence of foreign material.	Replace the valve.
	Wrong load pressure in the valve for the system's refrigerant.	Purge or bleed the refrigerant or the non-
	Excess load or air in the system.	condensables, as needed. Remove the obstruction or open the
	Obstruction or closed valve in the condenser's discharge or draining line.	valve.
	The liquid line's solenoid valve does not open.	Check the solenoid valve.
3. The system does not start or shortens the cycles in the low pressure fail switching after the interruption or defrosting.	The thermostatic valve does not manage to supply due to the loss of load or other reason.	Replace or repair the thermostatic valve.

X-Electrical Diagrams

Control Sequence

In the next pages, we placed electrical diagrams for the Genius and Diamond Air Conditioning units.

With an educational purpose, we explain the diagrams for the SRVE-100/125/150 equipments.

The conditioner is turned on through the ON-OFF switch in the lower part of the thermostat. When turned on, we'll have power on the G terminal (electrical diagram of the SRDV-100/125/150), and if the RS1 overload relay is closed, it will turn on the C1 counter, which feeds the evaporator's fan. Two auxiliary contacts, one for each compressor, energize their circuits.

If the thermostat requests, a refrigeration stage will feed the Y1 terminal, with which it will turn on the C3 counter that feeds the first compressor. This will work if the high and low pressure controls are closed.

At the same time, when closing the C3 counter, the C3 auxiliary (in parallel with the C4 auxiliary) contacts close, which turns on the condenser fan of the C2 counter.

It also feeds the TR time relay, which has a serial contact with the

counter from the second C4 compressor (15 sec. delay), in order to avoid that both compressors get in at the same time, thus avoiding the startup peak.

If the thermostat requests, more cold will be fed to the Y2 terminal, what makes the second compressor to start working in case the high and low pressure controls are closed.

The disconnection of the compressors is achieved in the reverse meaning that, by diminishing the temperature, the second phase of the thermostat will be turned off, no longer supplying power to the Y2 terminal, thus turning it off.

By lowering the temperature even some more until reaching the desired temperature, the thermostat cuts off the power supply to the Y1 terminal, with which it will turn off the compressor.

By turning it off, it will open its auxiliary contact and also close the condenser's fan, leaving the evaporator fan working, which will only stop working when the ON-OFF switch is set to the OFF position.

Electrical Diagrams

Genius

Figure X-01 - Power Electrical Diagram and SAVE Command 050/075 1t 3t 50/60Hz - Standard

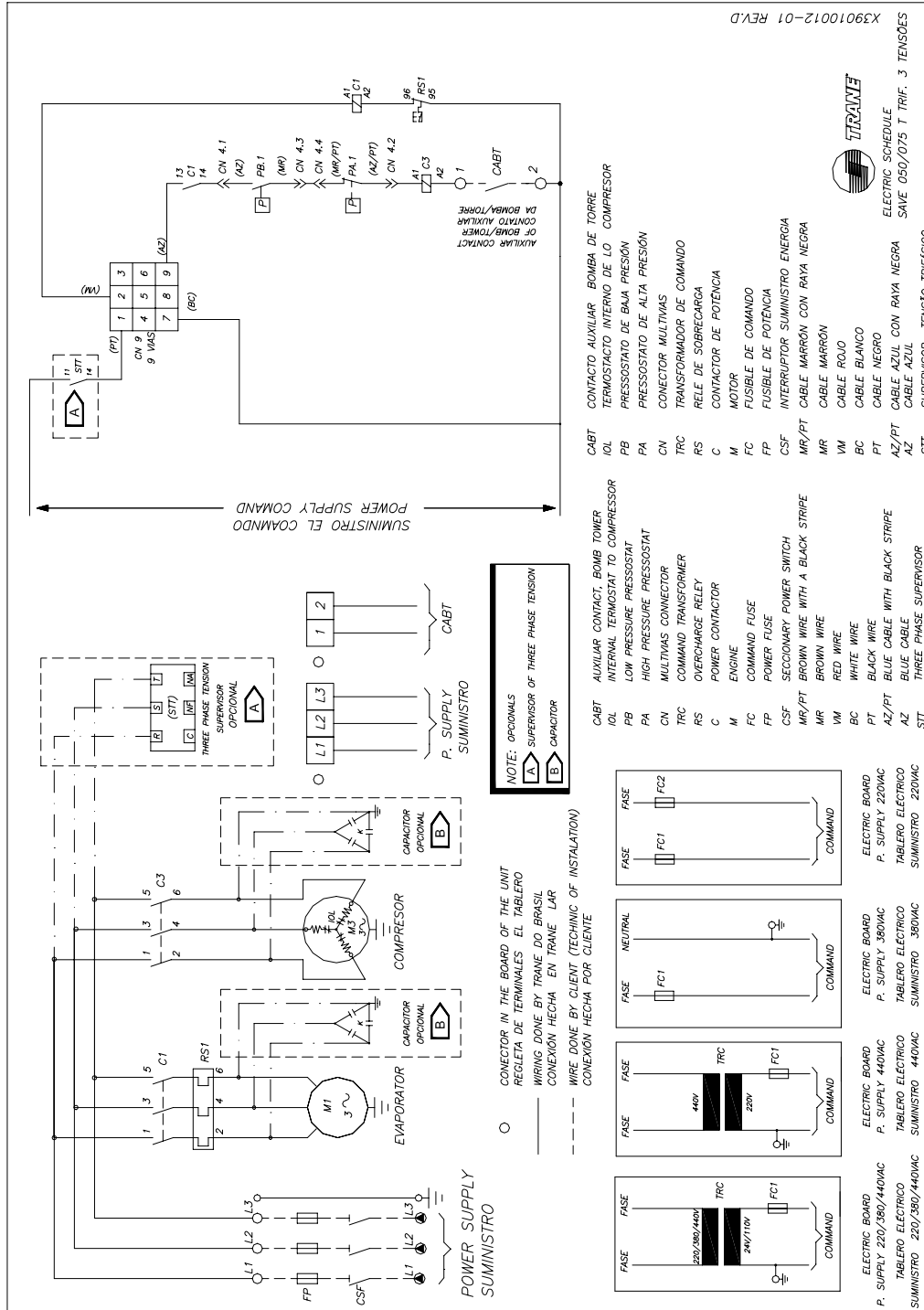

X39010012-01 REV.D

Electrical Diagrams

Genius

Figure X-02- Power Electrical Diagram and SAVE Command 050/075 1t 3t 50/60H - With Heating 1 or 2 Stages

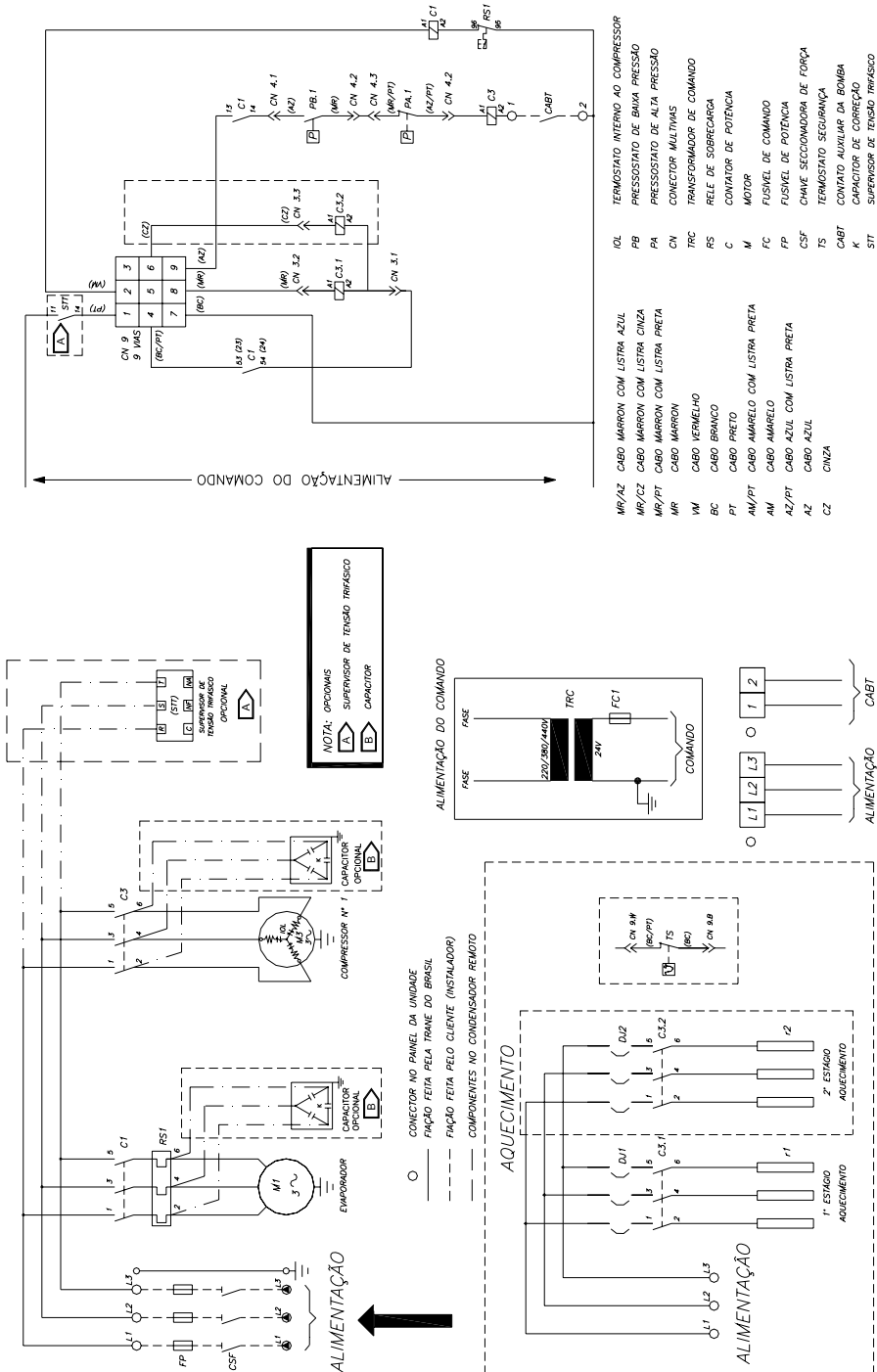

Electrical Diagrams

Figure X-03 - Power Electrical Diagram and SAVE Command 050/075 1t 3t 50/60H - With RTRM

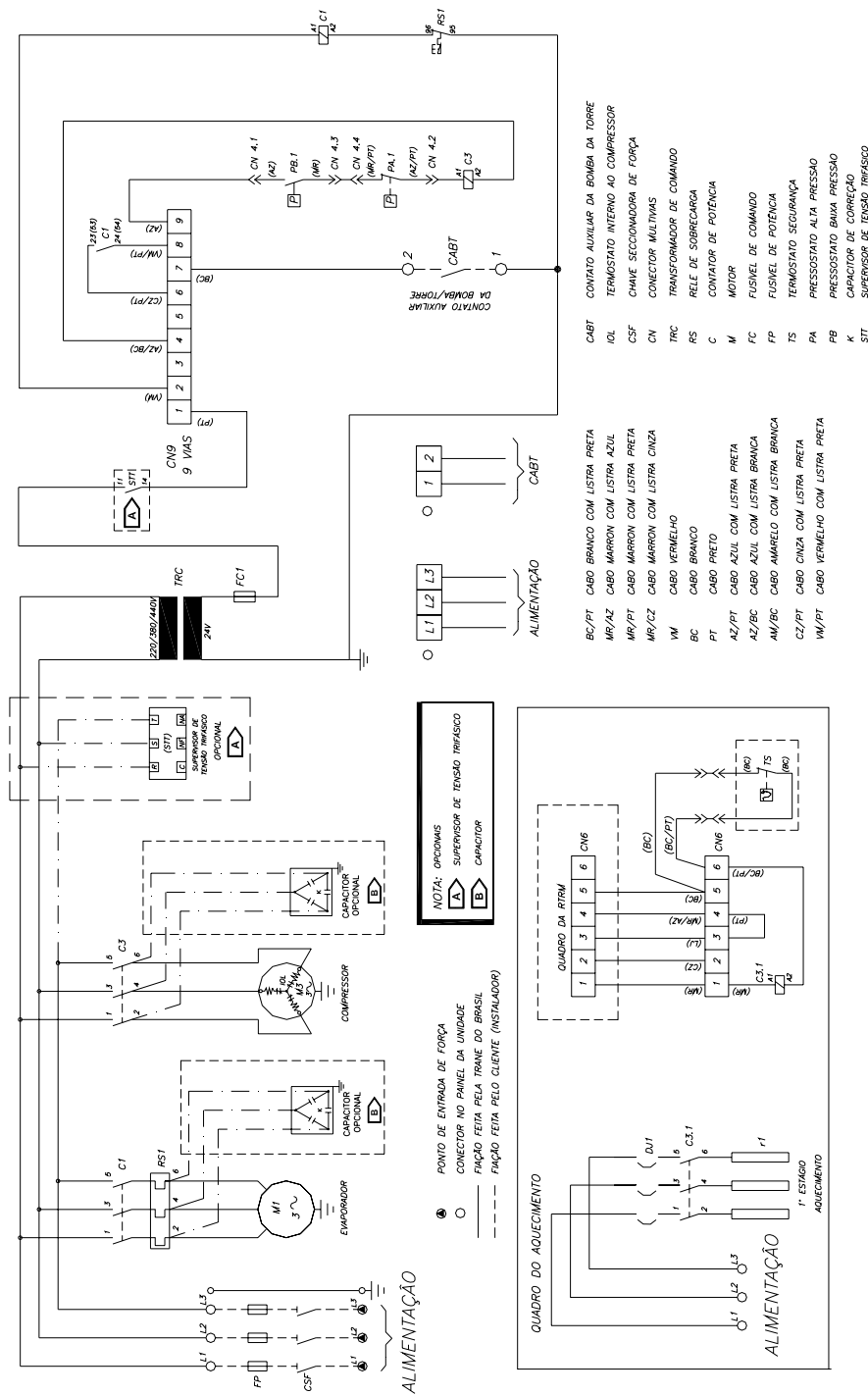

Electrical Diagrams

Figure X-04 - Power Electrical Diagram and SAVE Command 100/125/150 2t 3t 50/60Hz - Standard

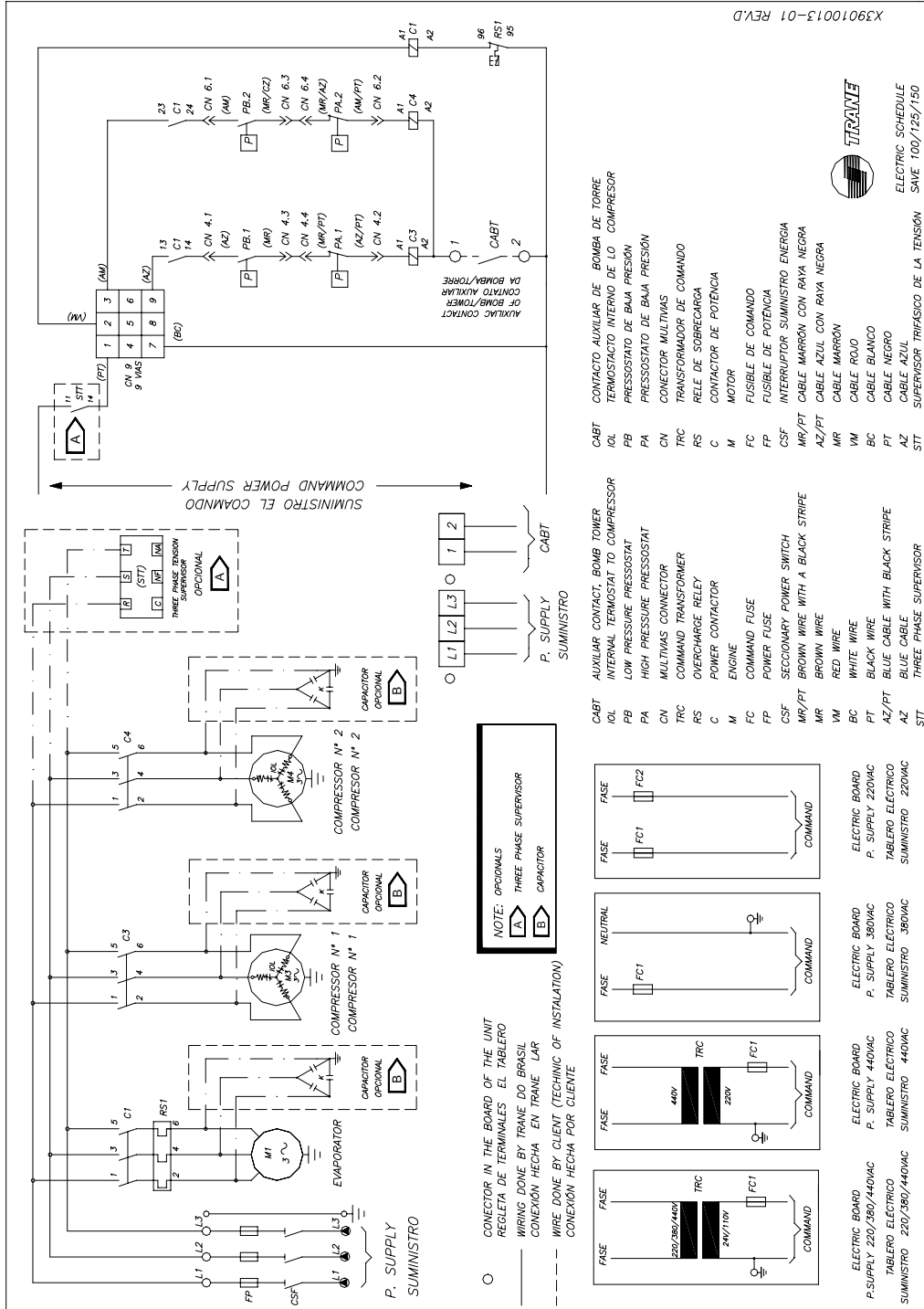

Electrical Diagrams

Genius

Figure X-05 - Power Electrical Diagram and SAVE Command 100/125/150 2t 3t 50/60HZ - With Heating 1 or 2 Stages

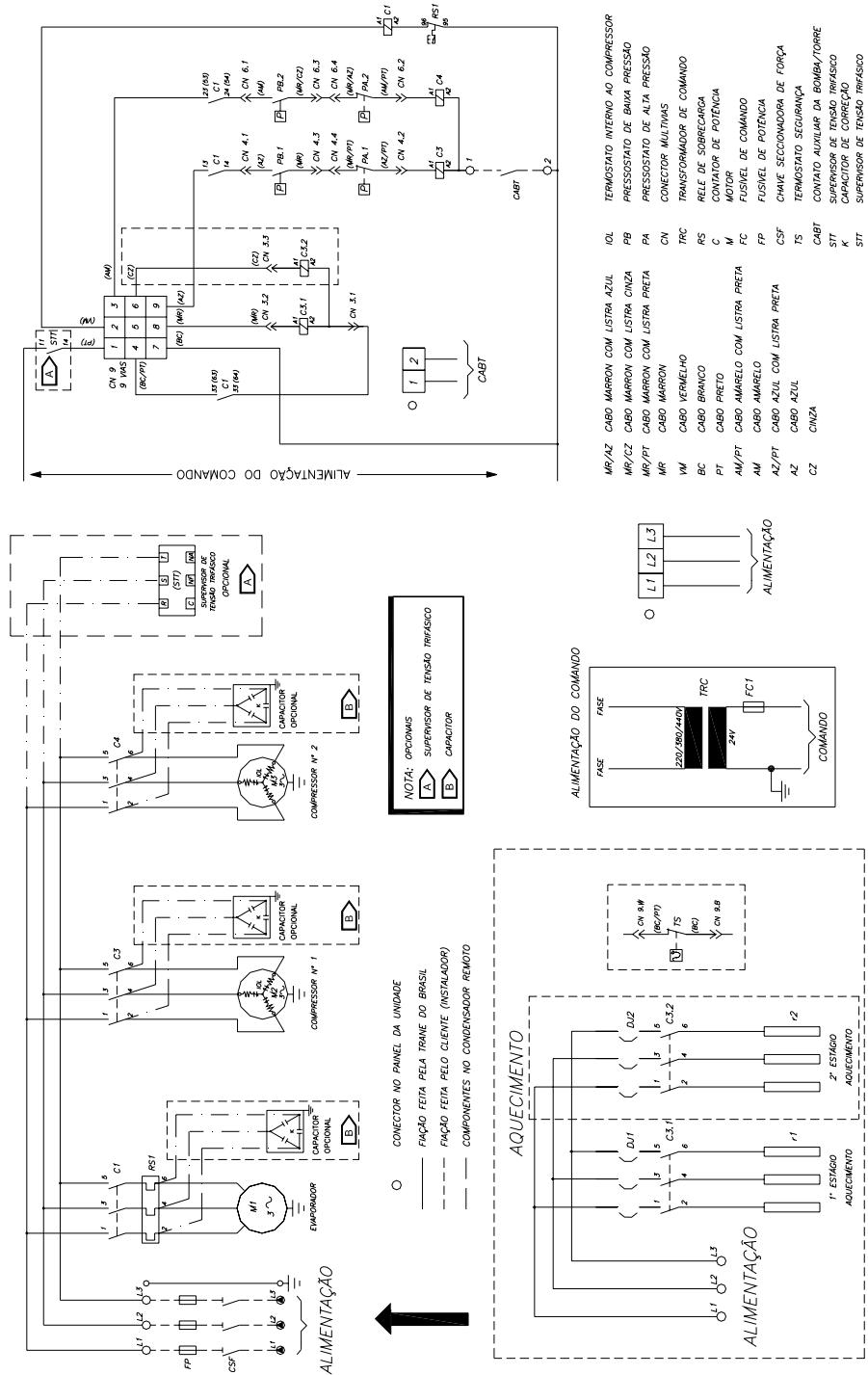

Electrical Diagrams

Genius

Figure X-06 - Power Electrical Diagram and SAVE Command 100/125/150 2t 3t 50/60HZ - With RTRM

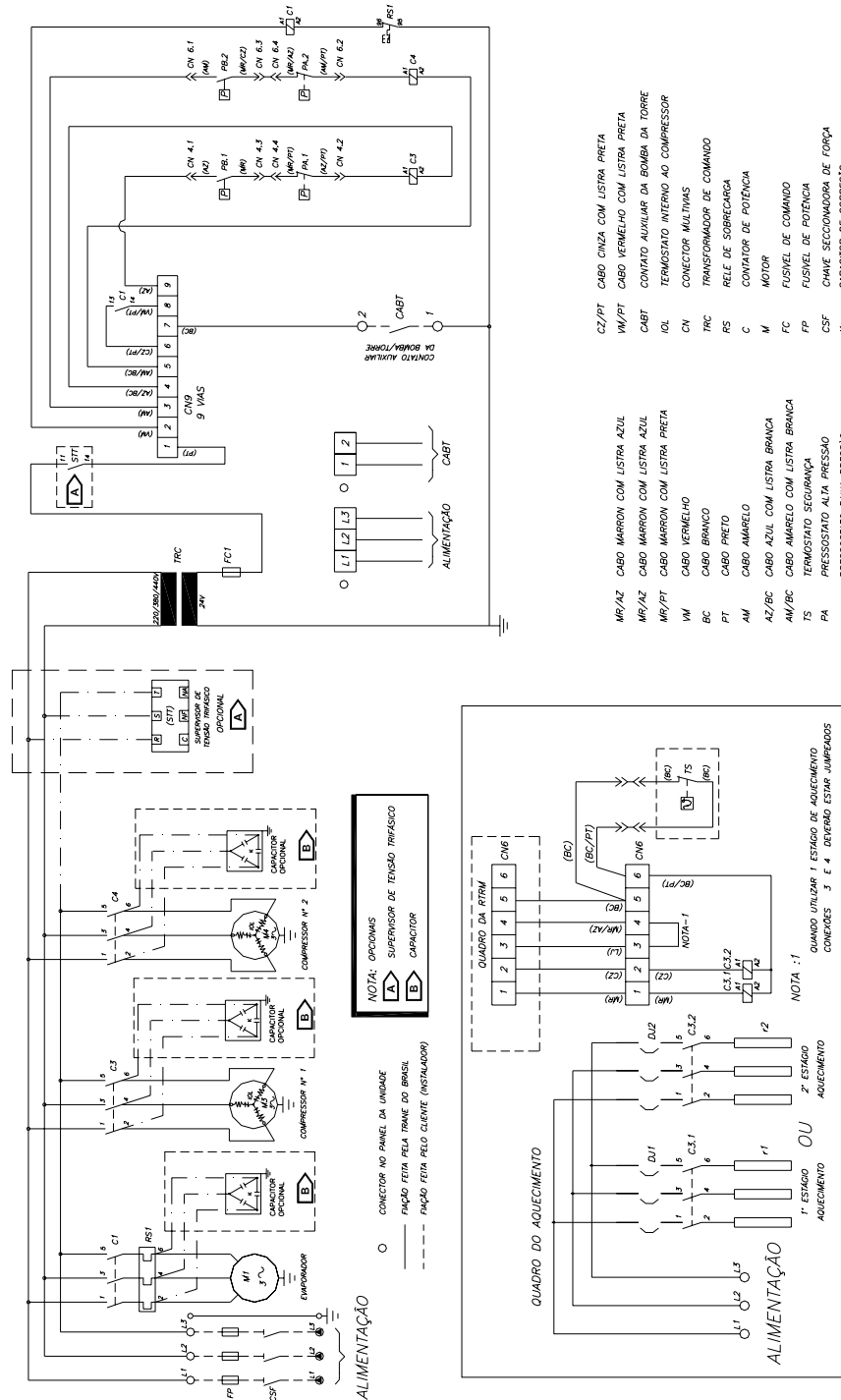

Electrical Diagrams

Diamond

Figure X-07 - Power Electrical Diagram and SAVE Command 200/350 - 50/60HZ - Standard

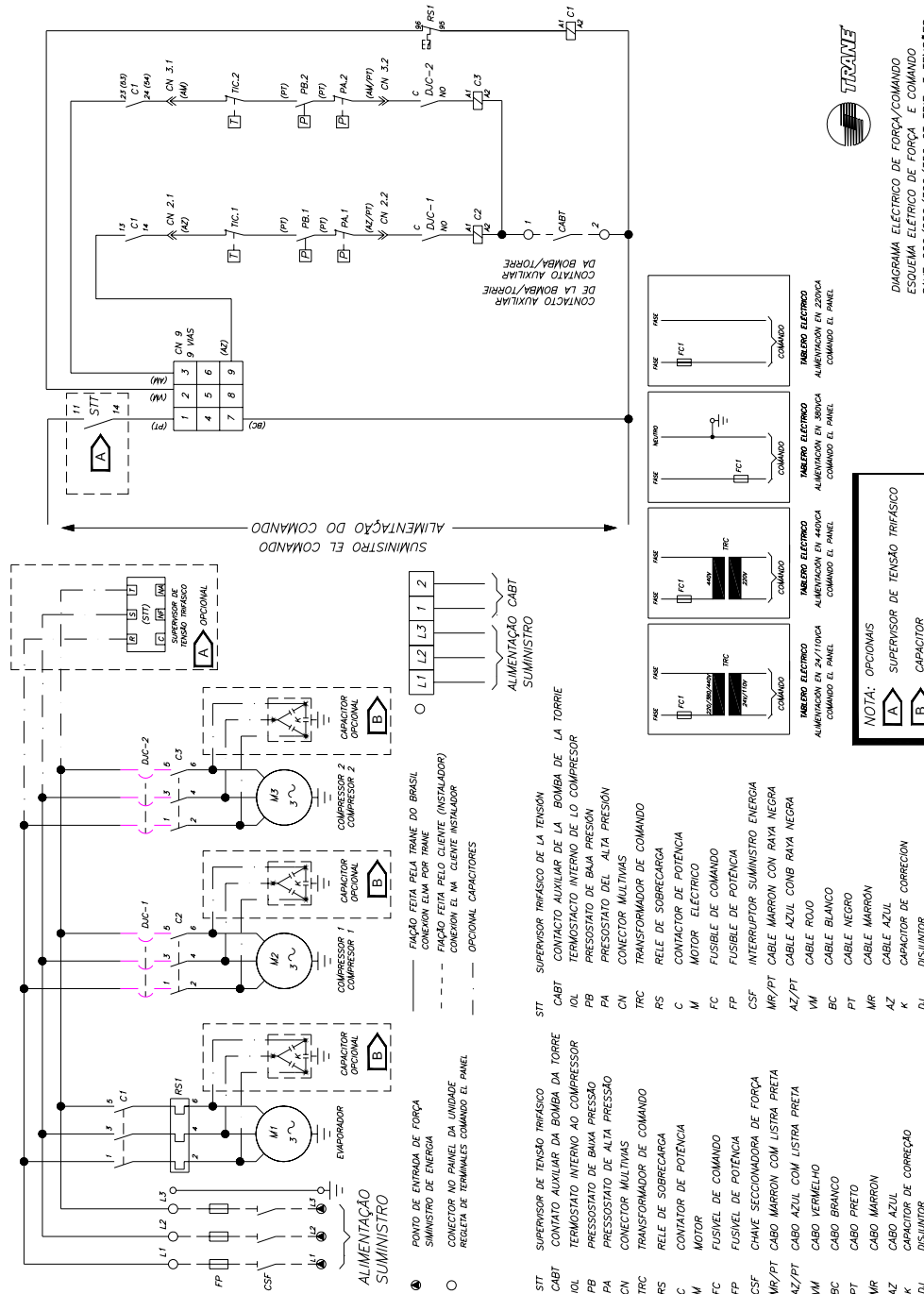

Electrical Diagrams

Diamond

Figure X-08 - Power Electrical Diagram and SAVE Command 400 - 50/60HZ - Standard

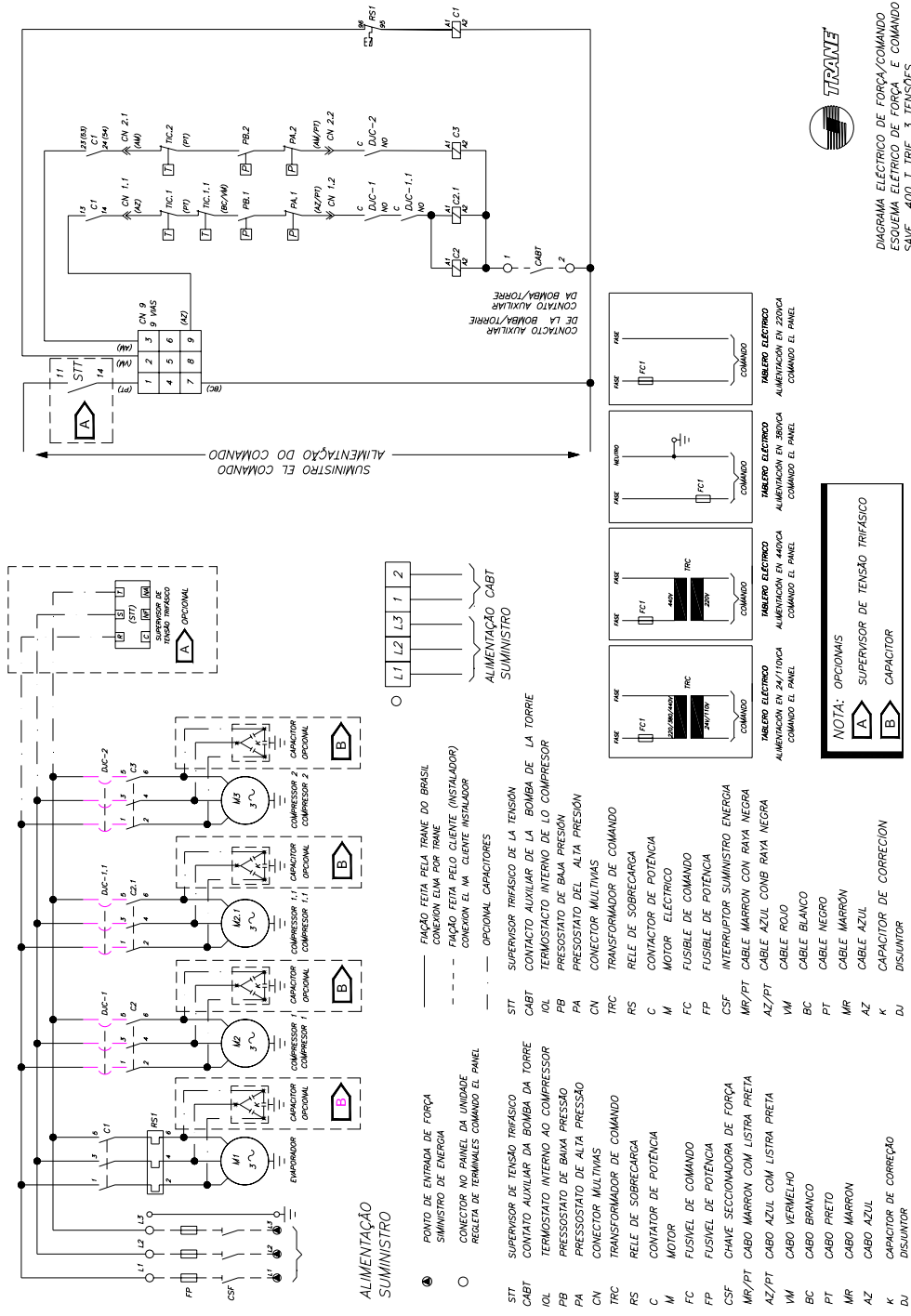

Electrical Diagrams

Genius

Figure X-09 - Power Electrical Diagram and SIVE Command 050/075 1T 3T 50/60Hz - Standard

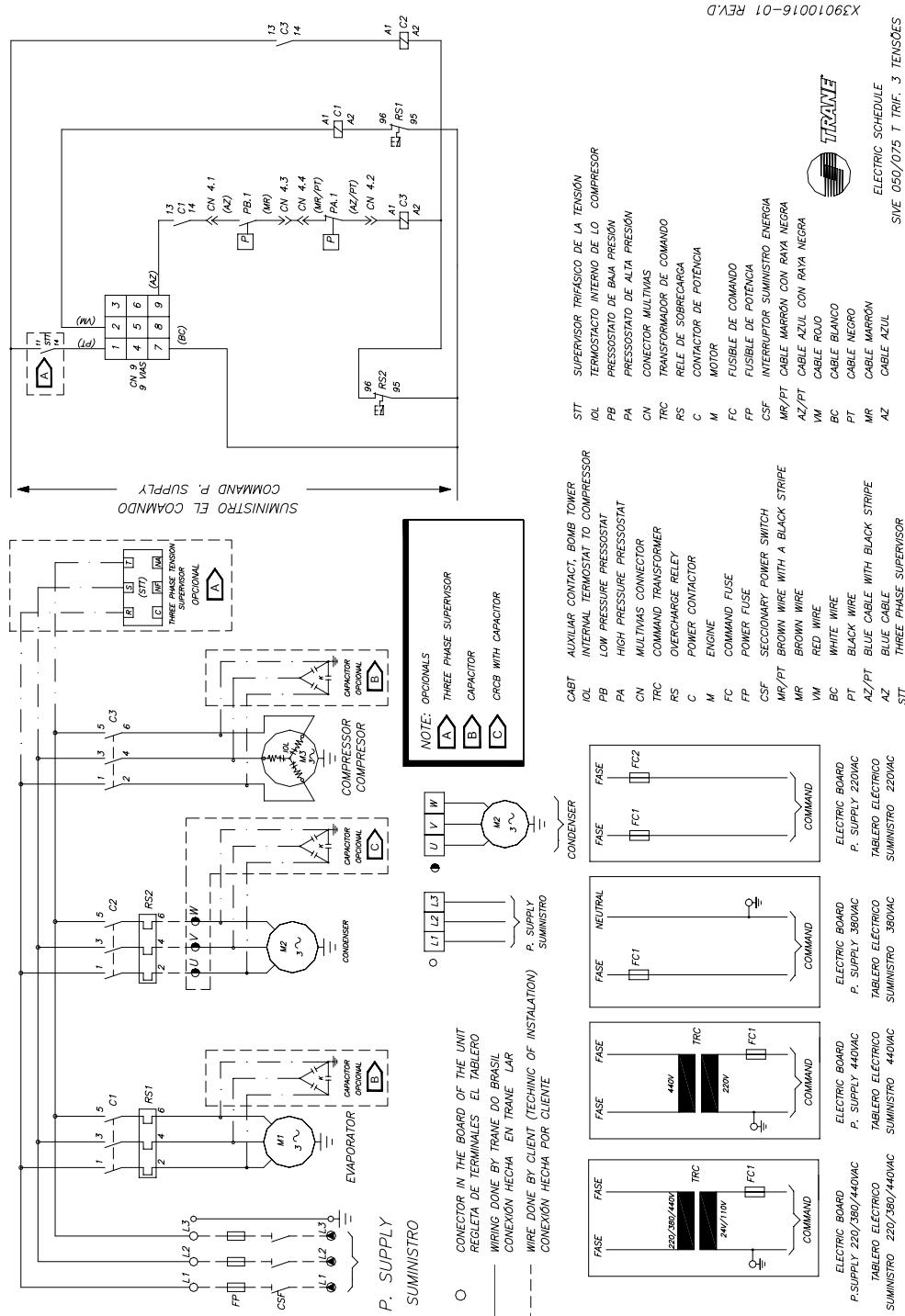

X39010016-01 REV.0

Electrical Diagrams

Genius

Figure X-11 - Power Electrical Diagram and SIVE Command 050/075 1T 3T 50/60HZ - With RTRM

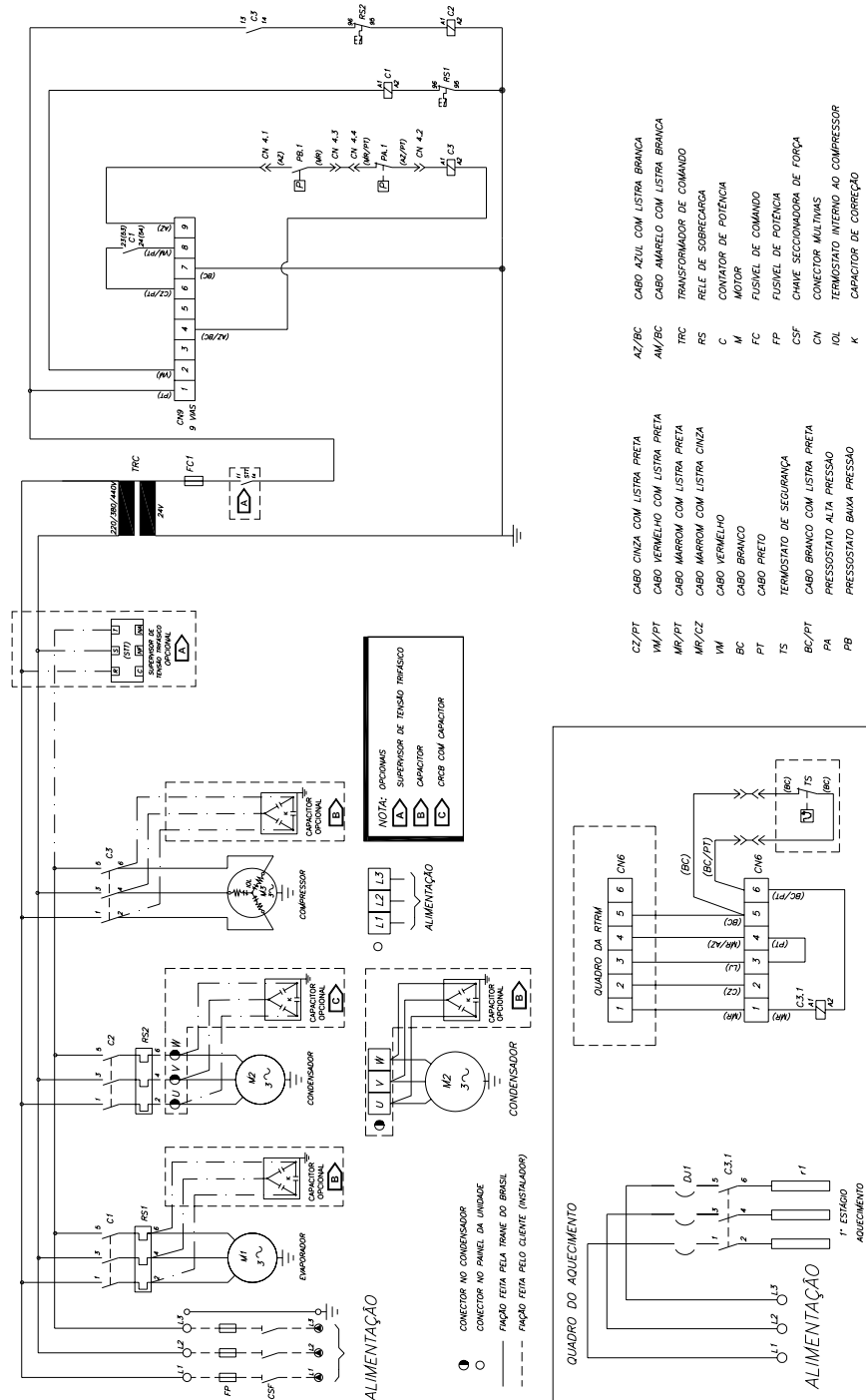

Electrical Diagrams

Genius

Figure X-12 - Power Electrical Diagram and SIVE Command 100/125/150 2T 3T 50/60HZ - Standard

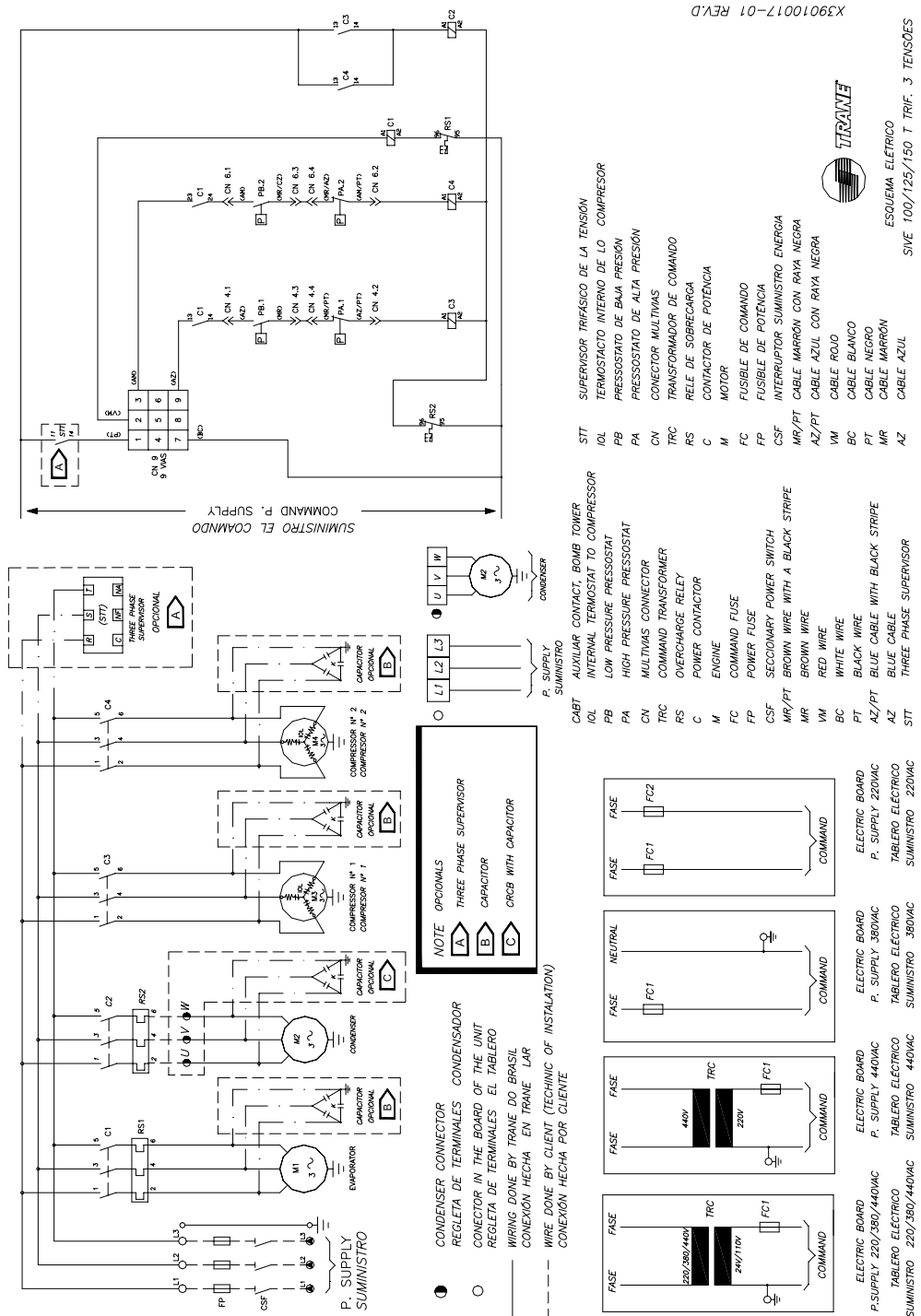

Electrical Diagrams

Genius

Figure X-13 - Power Electrical Diagram and SIVE Command 100/125/150 2T 3T 50/60HZ - With Heating 1 or 2 Stages

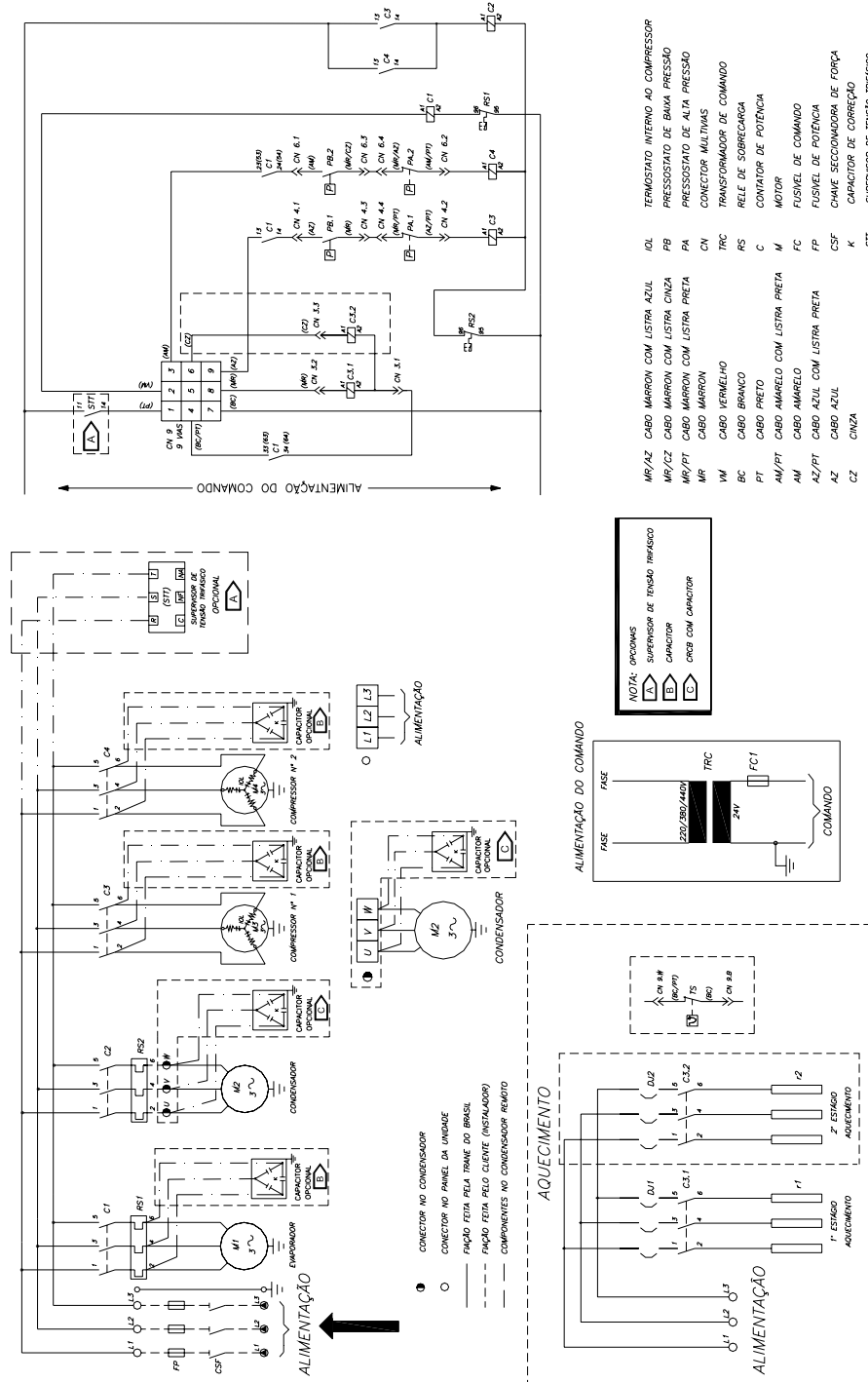

Electrical Diagrams

Genius

Figure X-14 - Power Electrical Diagram and SIVE Command 100/125/150 2T 3T 50/60HZ - With RTRM

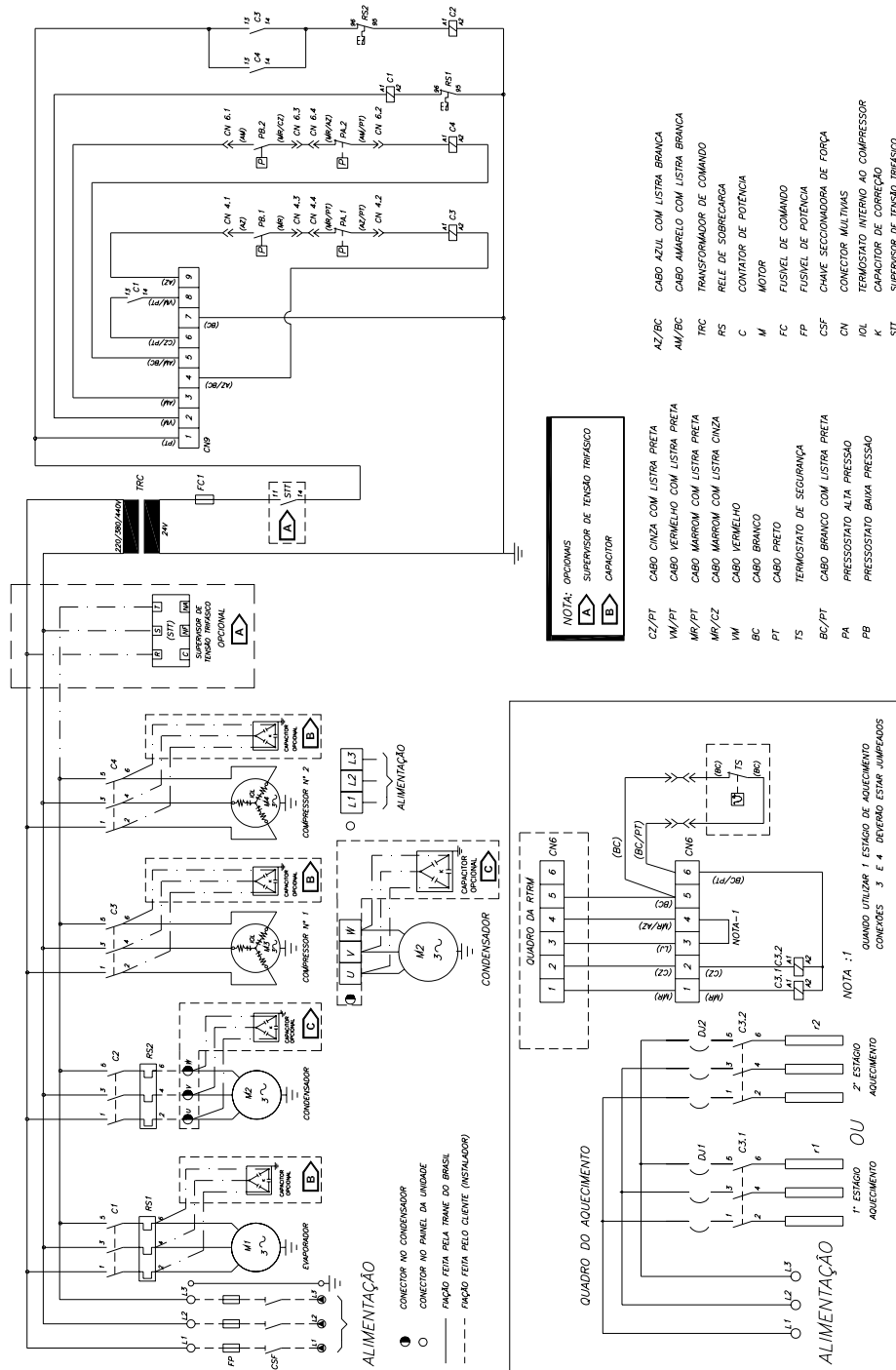

Electrical Diagrams

Diamond

Figure X-15 - Power Electrical Diagram and SIVE Command 200/350 2T 3T 50/60HZ - Standard

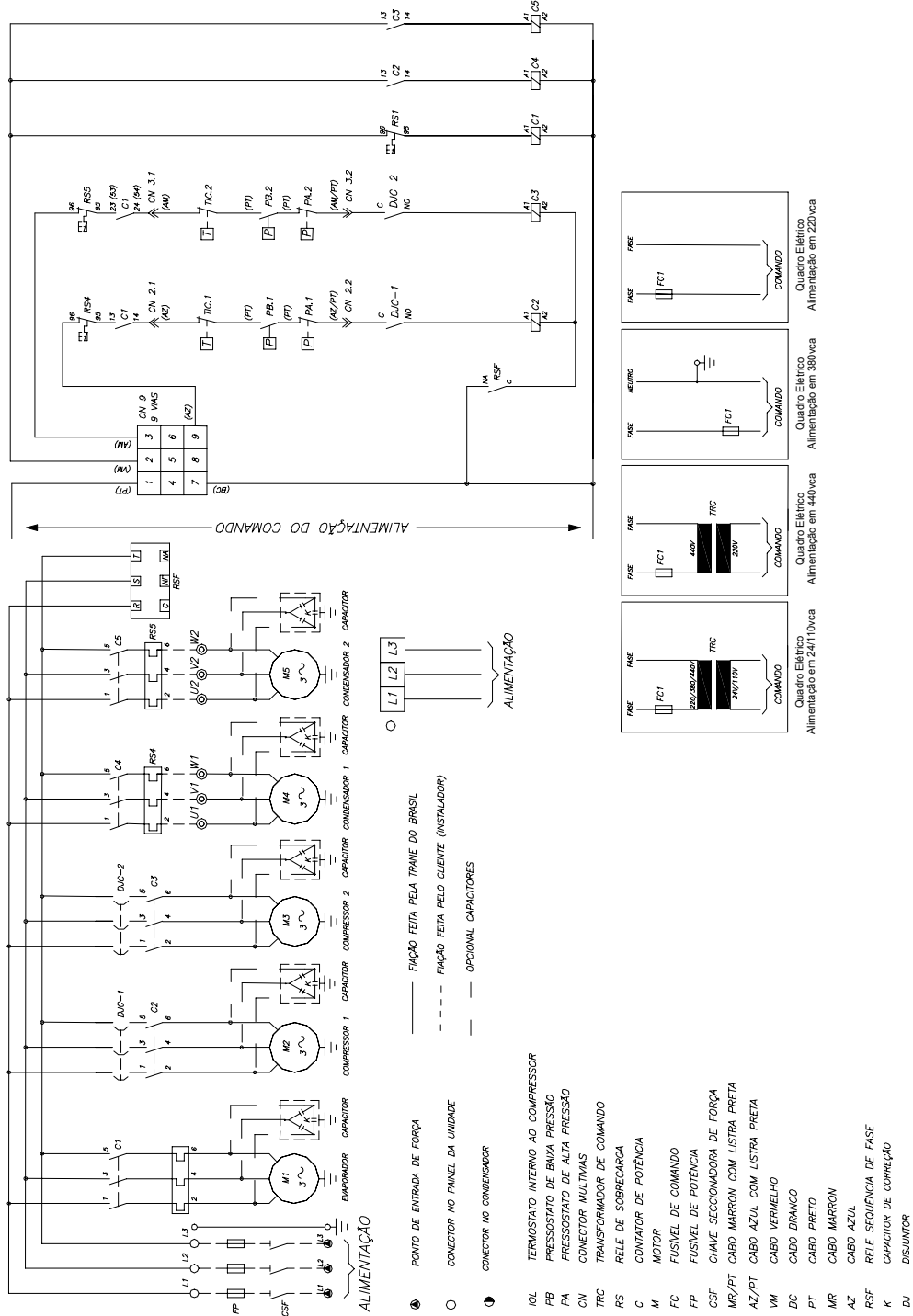

Electrical Diagrams

Genius

Figure X-16 - Power Electrical Diagram and SRVE Command 050/075 2T 3T 50/60Hz - Standard

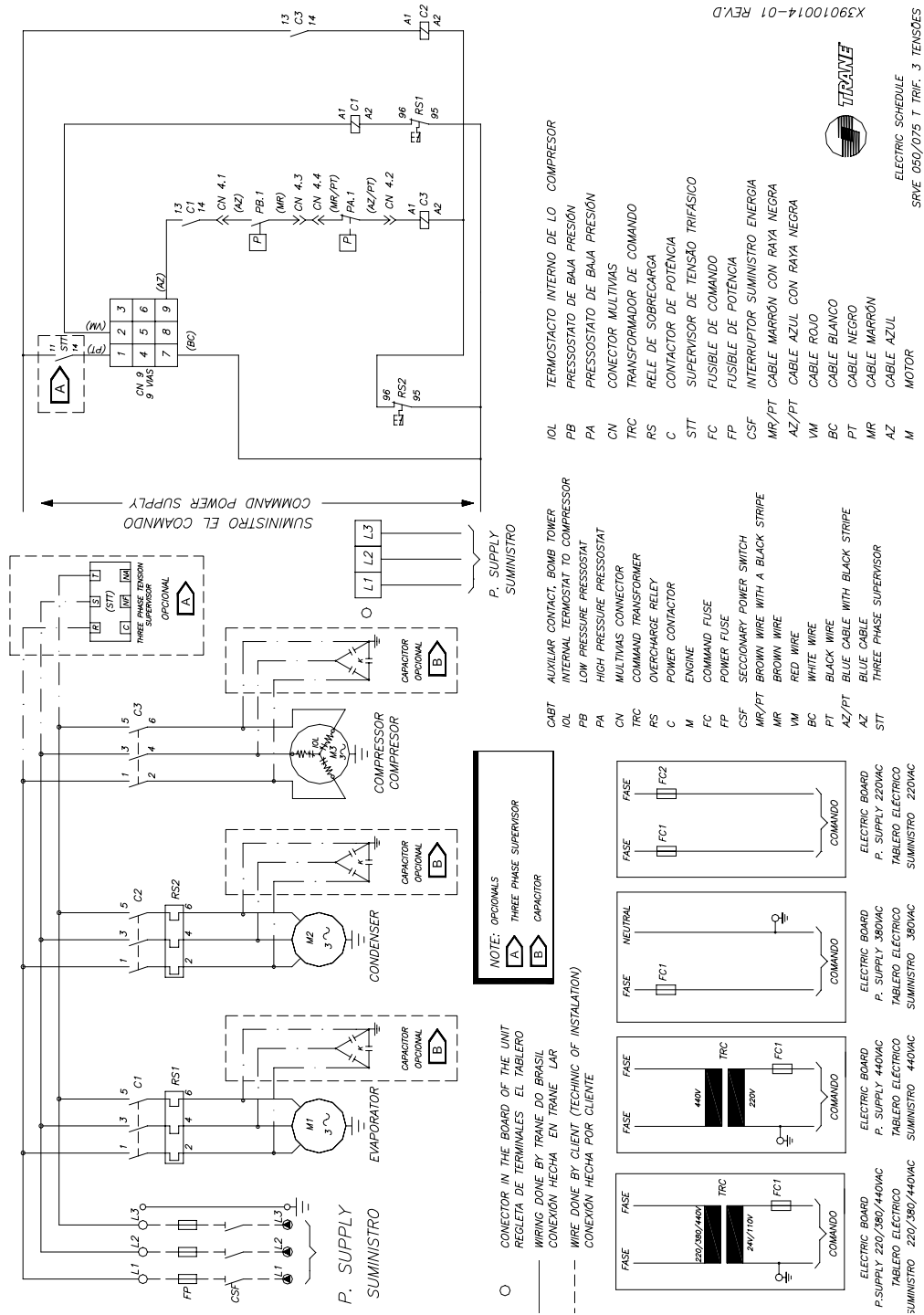

Electrical Diagrams

Genius

Figure X-17 - Power Electrical Diagram and SRVE Command 050/075 2T 3T 50/60HZ - With Heating 1 or 2 Stages

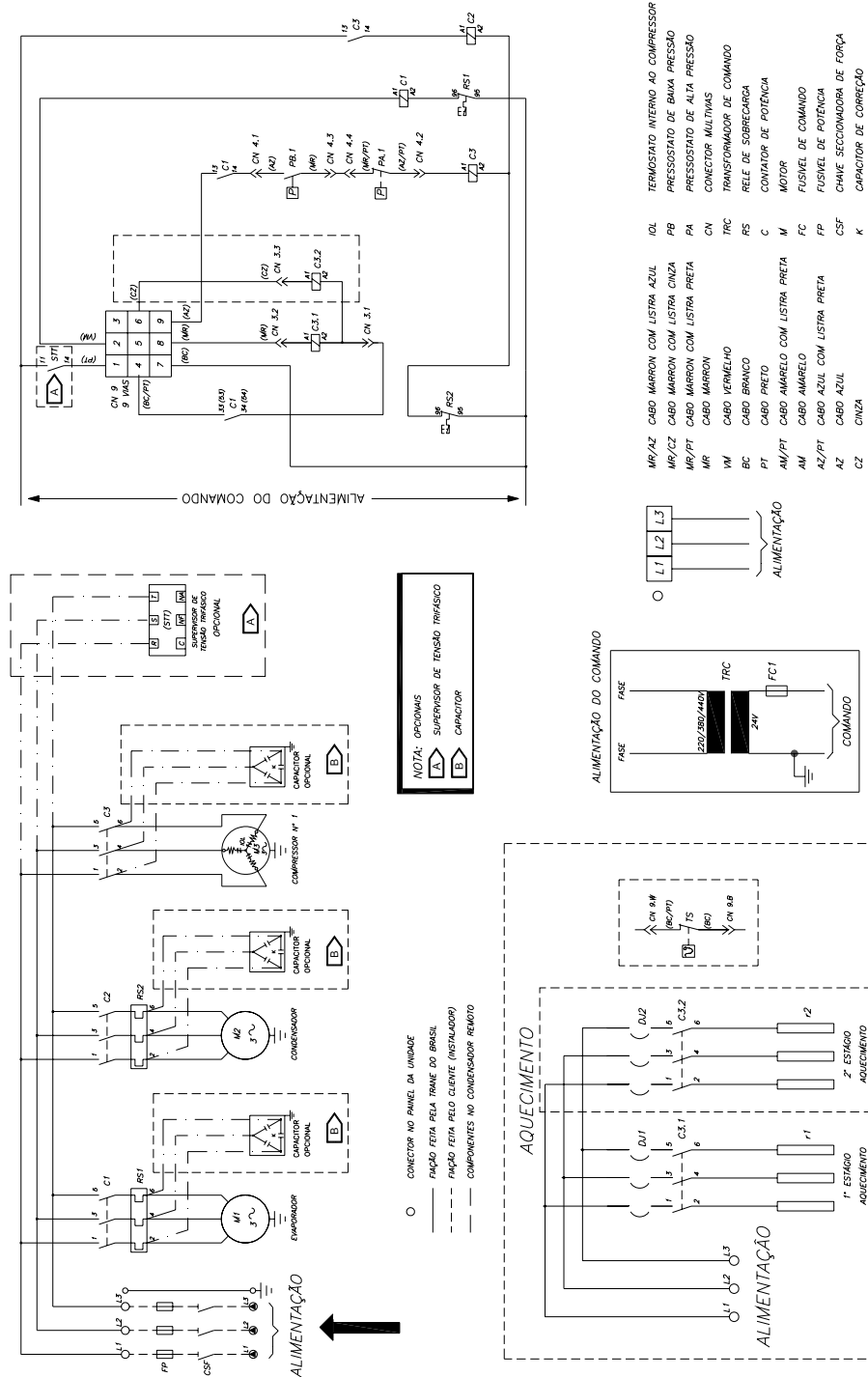

Electrical Diagrams

Genius

Figure X-19 - Power Electrical Diagram and SRVE Command 100/125/150 2T 3T 50/60Hz - Standard

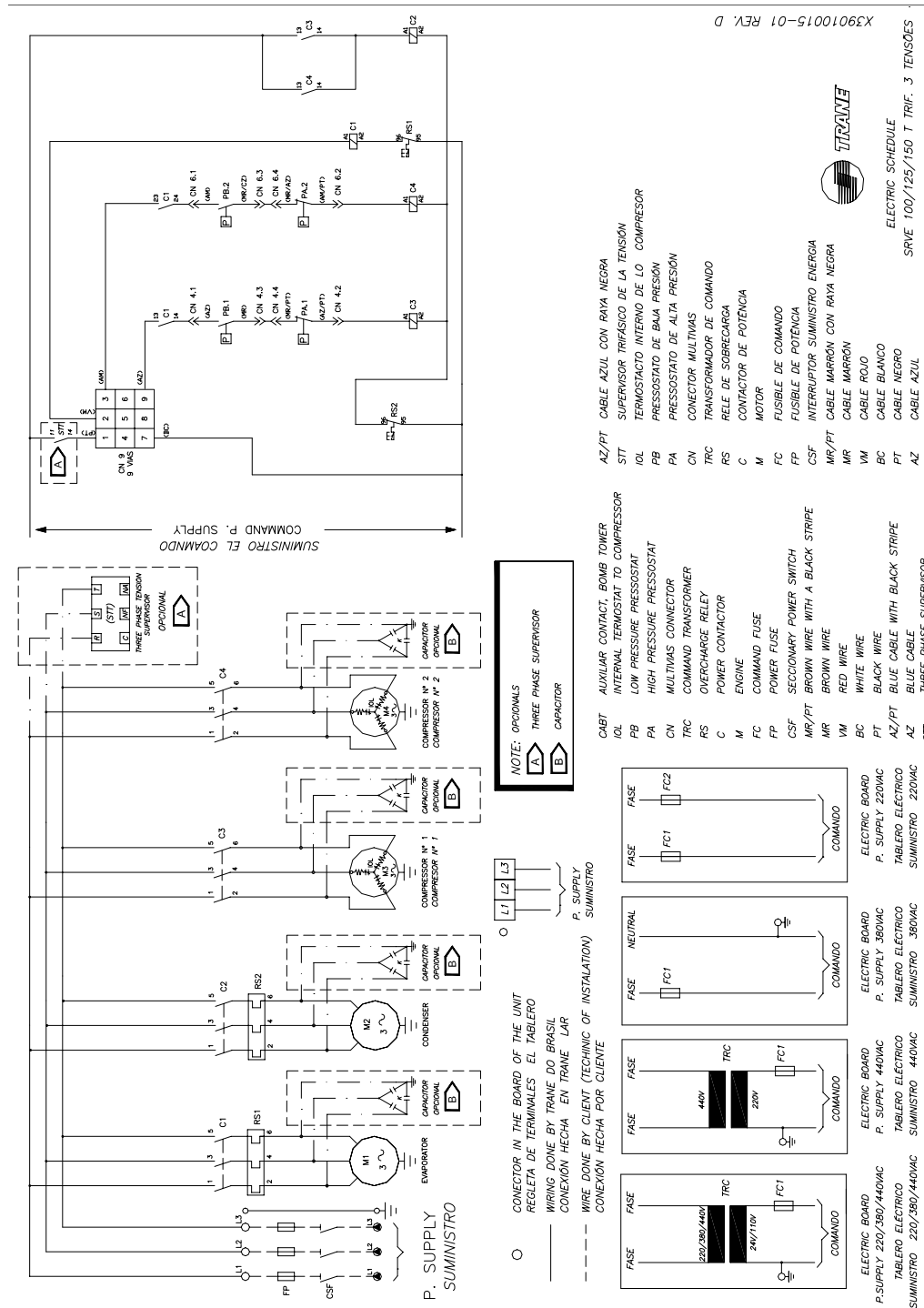

Electrical Diagrams

Genius

Figure X-20 - Power Electrical Diagram and SRVE Command 100/125/150 2T 3T 50/60HZ - Heating 1 or 2 Stages

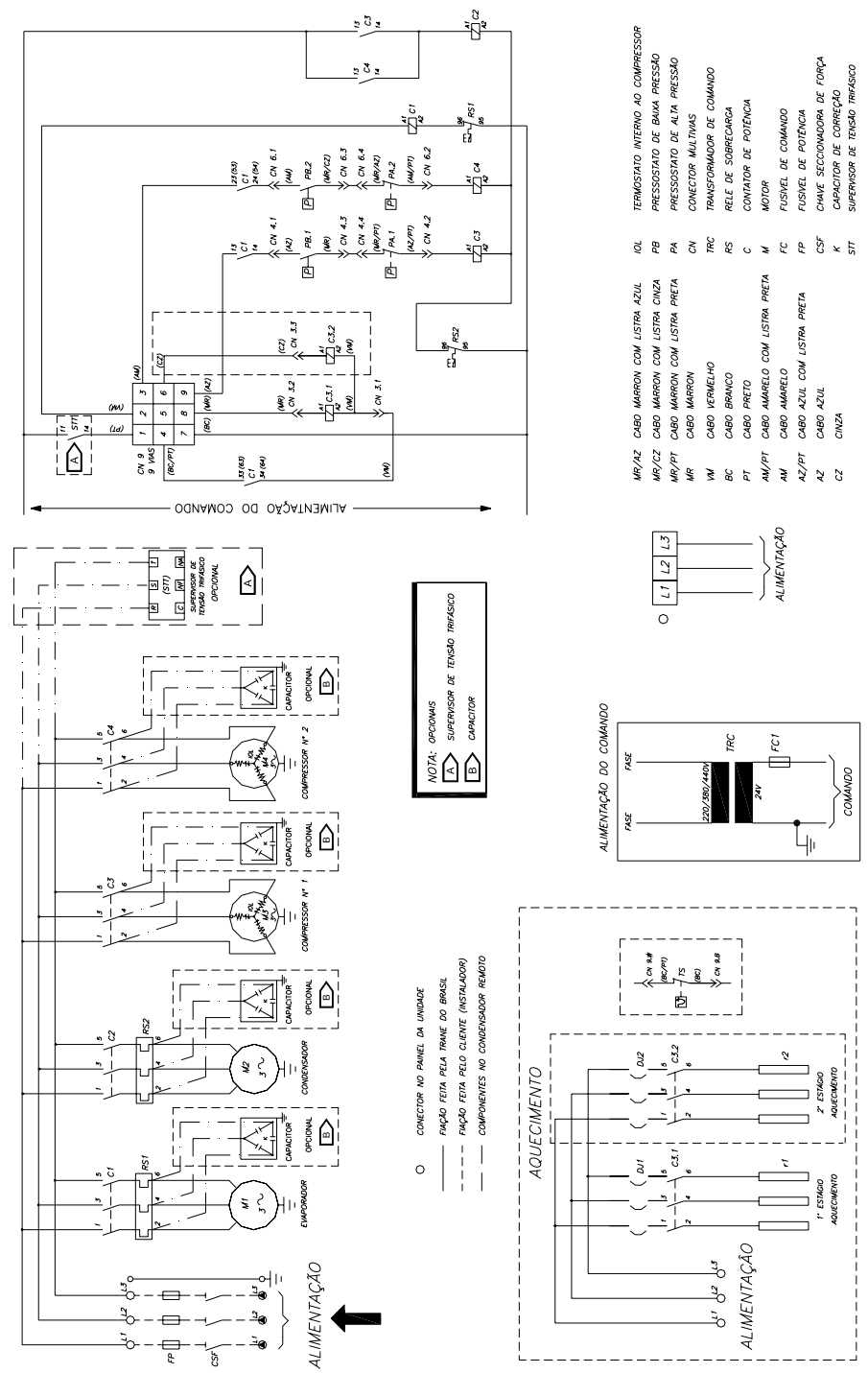

Electrical Diagrams

Genius

Figure X-21 - Power Electrical Diagram and SRVE Command 100/125/150 2T 3T 50/60HZ - With RTRM

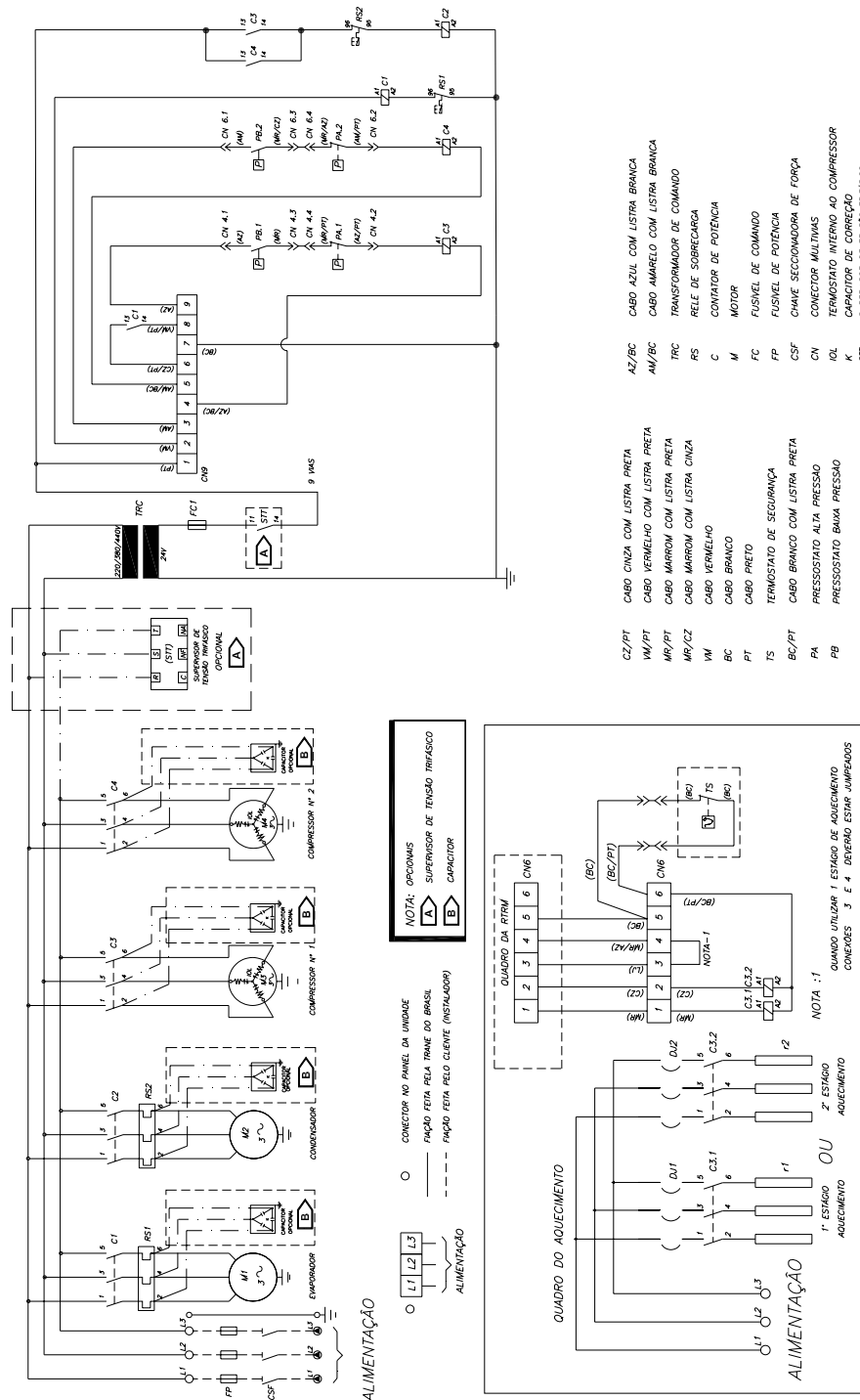

Electrical Diagrams

Genius

Figure X-22 - Power Electrical Diagram and SSVE

D2313-1015

ESQUEMA ELÉTRICO SSVE
 INTERFACE UNID. CONDENSADORA
 EMPAPADORA PADRÃO
 EMPAPADORA PADRÃO C/ AQUECIMENTO

NOTA : FAÇO COMANDO Ø 1,0 mm2 (M)
 --- FAÇO QUANDO UTILIZAR CAPACITOR
 --- CABLEADO QUANDO UTILICE CARACTOR
 --- FAÇO PELA REJA TRANE DO BRASIL
 --- CONEXÃO HECHA POR TRANE

NOTAS:
 [A] UTILIZAR QUANDO MÁQUINA PADRÃO
 [B] HECHO QUANDO UNIDAD PADRÃO
 [C] UTILIZAR QUANDO MÁQUINA PADRÃO C/ AQUECIMENTO
 HECHO QUANDO UNIDAD PADRÃO /CALENTAMIENTO
 [D] UTILIZAR SIEMPRE PARA ALIMENTAÇÃO DO AQUECIMENTO
 INSERIR PONTES QUANDO SUMINISTRO CALENTAMIENTO

[UTILIZAR JUNTO COM 2313-1010-01]
 [UTILIZAR CON 2313-1010-01]

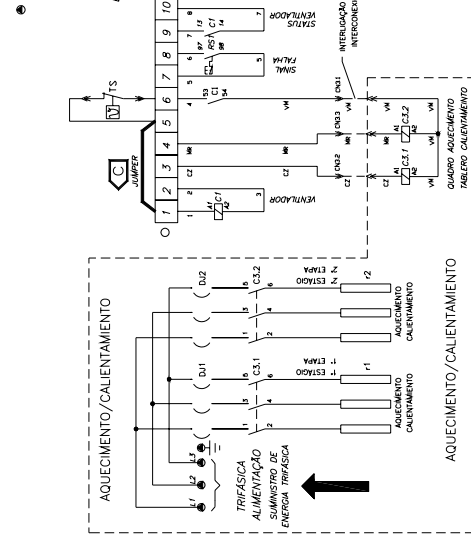
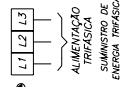
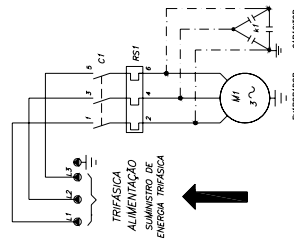
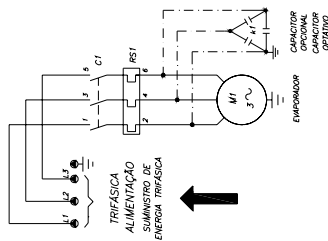
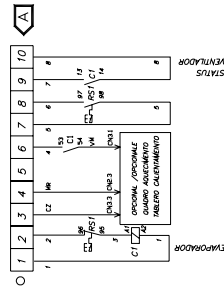

M MOTOR/MOTOR
 C CONVIDOR DE POTENCIA/CONVIDOR DE POTENCIA
 CN CONECTOR MULTIAS/CONECTOR MULTIAS
 K CAPACITOR DE CORREÇÃO
 CAPACITOR DE CORREÇÃO
 M CABO VERMELHO/CABE ROJO
 AZ CABO AZUL/CABLE AZUL
 AM CABO AMARELO/CABLE AMARILLO
 RS RELE SOBRECARGA / RELE SOBRECARGA

Electrical Diagrams

Genius

Figure X-23 - Connection Diagram and SSVE

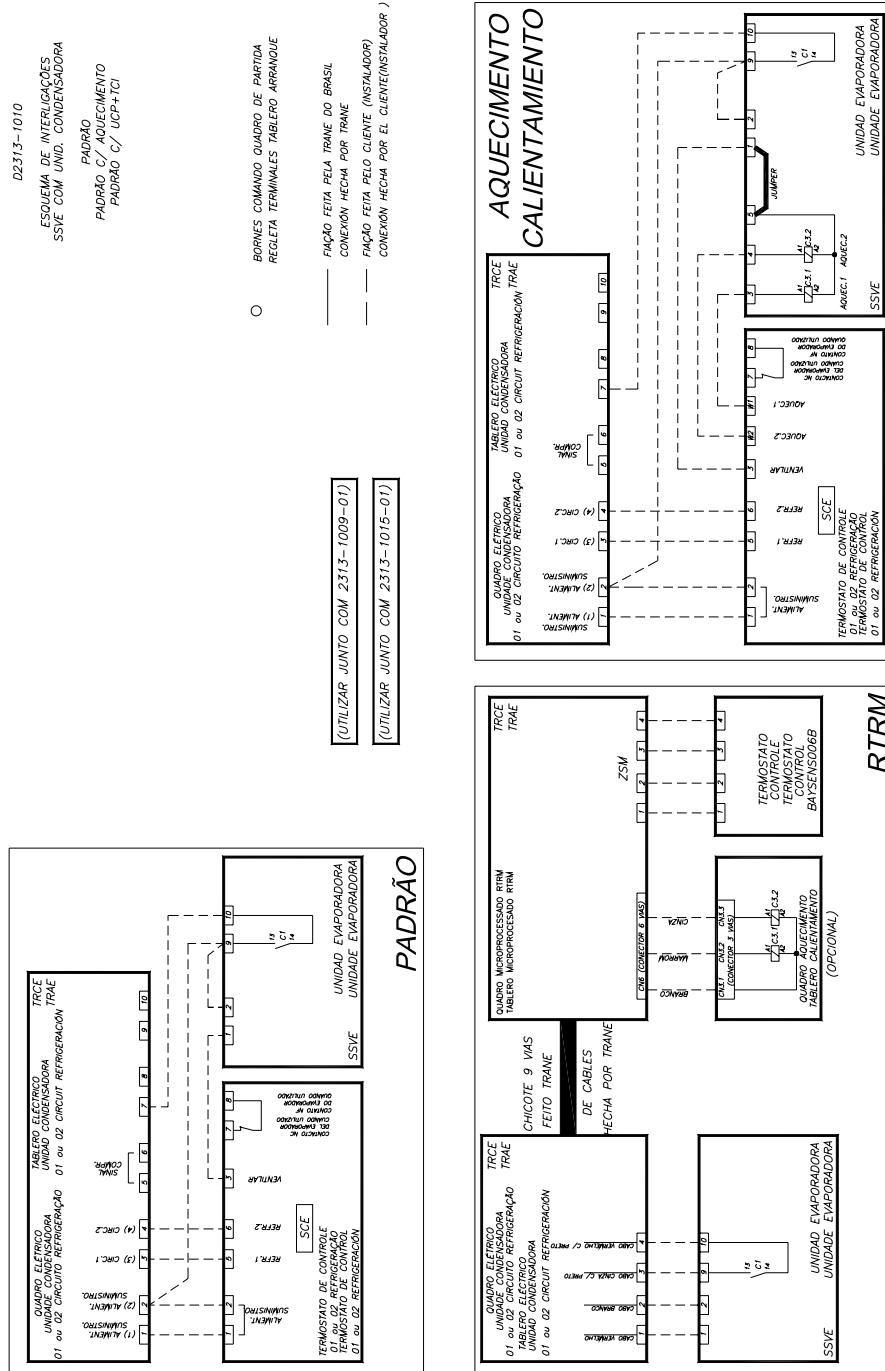



XI-Conversion Table

To convert from:	To:	Multiply By:	To convert from:	To:	Multiply By:
Length			Velocity		
Feet (ft)	meters (m)	0,30481	Feet per minute (ft/min)	meters per second (m/s)	0,00508
Inche (in)	milimeters (mm)	25,4	Feet per second (ft/s)	meters per second (m/s)	0,3048
Area			Energy, Power and Capacity		
Square feet (ft ²)	square meters(m ²)	0,93	British Termal Units (BTU)	Kilowatt (kW)	0,000293
Square inche(in ²)	square milimeters(mm ²)	645,2	British Termal Units (BTU)	Kilocalorie (kcal)	0,252
Volume			Tons (refrig. Effect)	Kilowatt (kW)	3,516
Cubic feet (ft ³)	cubic meters(m ³)	0,0283	Tons (refrig. Effect)	Kilocalorie per hour (kcal/h)	3024
Cubic Inches (in ³)	cubic milimeters (mm ³)	16387	Horsepower (HP)	Kilowatt (kW)	0,7457
Gallons (gal)	litres (L)	3,785	Pressão		
Gallons (gal)	cubic meters (m ³)	0,003785	Feet of water (ft.H ₂ O)	Pascal (Pa)	2990
Flow			Inches os water (in.H ₂ O)	Pascal (Pa)	249
Cubic feet / min (cfm)	cubic meters / second (m ³ /s)	0,000472	Pounds per square inch (PSI)	Pascal (Pa)	6895
Cubic feet / min (cfm)	cubic meters / hour (m ³ /h)	1,69884	Pounds per square inch (PSI)	Bar ou kg/cm ²	6,895 x 10 ⁻²
Gallons / min (GPM)	cubic meters / hour (m ³ /h)	0,2271	Peso		
Gallons / min (GPM)	litres / second (L/s)	0,06308	Ounces (oz)	Kilograms (kg)	0,02835
			Pounds (lbs)	Kilograms (kg)	0,4536

Temperature		
°C	1 C ou F 1	—/—
-40,0	-40	-40
-39,4	-39	-38,2
-38,9	-38	-36,4
-38,3	-37	-34,6
-37,8	-36	-32,8
-37,2	-35	-31
-36,7	-34	-29,2
-36,1	-33	-27,4
-35,6	-32	-25,6
-35,0	-31	-23,8
-34,4	-30	-22
-33,9	-29	-20,2
-33,3	-28	-18,4
-32,8	-27	-16,6
-32,2	-26	-14,8
-31,7	-25	-13
-31,1	-24	-11,2
-30,6	-23	-9,4
-30,0	-22	-7,6
-29,4	-21	-5,8
-28,9	-20	-4
-28,3	-19	-2,2
-27,8	-18	-0,4
-27,2	-17	1,4
-26,7	-16	3,2
-26,1	-15	5
-25,6	-14	6,8
-25,0	-13	8,6
-24,4	-12	10,4
-23,9	-11	12,2
-23,3	-10	14
-22,8	-9	15,8
-22,2	-8	17,6
-21,7	-7	19,4
-21,1	-6	21,2
-20,6	-5	23
-20,0	-4	24,8
-19,4	-3	26,6
-18,9	-2	28,4
-18,3	-1	30,2
-17,8	0	32
-17,2	1	33,8
-16,7	2	35,6
-16,1	3	37,4
-15,6	4	39,2

Temperature		
°C	1 C ou F 1	°F
-15,0	5	41
-14,4	6	42,8
-13,9	7	44,6
-13,3	8	46,4
-12,8	9	48,2
-12,2	10	50
-11,7	11	51,8
-11,1	12	53,6
-10,6	13	55,4
-10,0	14	57,2
-9,4	15	59
-8,9	16	60,8
-8,3	17	62,6
-7,8	18	64,4
-7,2	19	66,2
-6,7	20	68
-6,1	21	69,8
-5,6	22	71,6
-5,0	23	73,4
-4,4	24	75,2
-3,9	25	77
-3,3	26	78,8
-2,8	27	80,6
-2,2	28	82,4
-1,7	29	84,2
-1,1	30	86
-0,6	31	87,8
0,0	32	89,6
0,6	33	91,4
1,1	34	93,2
1,7	35	95
2,2	36	96,8
2,8	37	98,6
3,3	38	100,4
3,9	39	102,2
4,4	40	104
5,0	41	105,8
5,6	42	107,6
6,1	43	109,4
6,7	44	111,2
7,2	45	113
7,8	46	114,8
8,3	47	116,6
8,9	48	118,4
9,4	49	120,2

T temperature		
°C	1 C ou F 1	°F
10,0	50	122
10,6	51	123,8
11,1	52	125,6
11,7	53	127,4
12,2	54	129,2
12,8	55	131
13,3	56	132,8
13,9	57	134,6
14,4	58	136,4
15,0	59	138,2
15,6	60	140
16,1	61	141,8
16,7	62	143,6
17,2	63	145,4
17,8	64	147,2
18,3	65	149
18,9	66	150,8
19,4	67	152,6
20,0	68	154,4
20,6	69	156,2
21,1	70	158
21,7	71	159,8
22,2	72	161,6
22,8	73	163,4
23,3	74	165,2
23,9	75	167
24,4	76	168,8
25,0	77	170,6
25,6	78	172,4
26,1	79	174,2
26,7	80	176
27,2	81	177,8
27,8	82	179,6
28,3	83	181,4
28,9	84	183,2
29,4	85	185
30,0	86	186,8
30,6	87	188,6
31,1	88	190,4
31,7	89	192,2
32,2	90	194
32,8	91	195,8
33,3	92	197,6
33,9	93	199,4
34,4	94	201,2

Temperature		
°C	1 C ou F 1	°F
35,0	95	203
35,6	96	204,8
36,1	97	206,6
36,7	98	208,4
37,2	99	210,2
37,8	100	212
38,3	101	213,8
38,9	102	215,6
39,4	103	217,4
40,0	104	219,2
40,6	105	221
41,1	106	222,8
41,7	107	224,6
42,2	108	226,4
42,8	109	228,2
43,3	110	230
43,9	111	231,8
44,4	112	233,6
45,0	113	235,4
45,6	114	237,2
46,1	115	239
46,7	116	240,8
47,2	117	242,6
47,8	118	244,4
48,3	119	246,2
48,9	120	248
49,4	121	249,8
50,0	122	251,6
50,6	123	253,4
51,1	124	255,2
51,7	125	257
52,2	126	258,8
52,8	127	260,6
53,3	128	262,4
53,9	129	264,2
54,4	130	266
55,0	131	267,8
55,6	132	269,6
56,1	133	271,4
56,7	134	273,2
57,2	135	275
57,8	136	276,8
58,3	137	278,6
58,9	138	280,4
59,4	139	282,2

Temperature		
°C	1 C ou F 1	°F
60,0	140	284
60,6	141	285,8
61,1	142	287,6
61,7	143	289,4
62,2	144	291,2
62,8	145	293
63,3	146	294,8
63,9	147	296,6
64,4	148	298,4
65,0	149	300,2
65,6	150	302
66,1	151	303,8
66,7	152	305,6
67,2	153	307,4
67,8	154	309,2
68,3	155	311
68,9	156	312,8
69,4	157	314,6
70,0	158	316,4
70,6	159	318,2
71,1	160	320
71,7	161	321,8
72,2	162	323,6
72,8	163	325,4
73,3	164	327,2
73,9	165	329
74,4	166	330,8
75,0	167	332,6
75,6	168	334,4
76,1	169	336,2
76,7	170	338
77,2	171	339,8
77,8	172	341,6
78,3	173	343,4
78,9	174	345,2
79,4	175	347
80,0	176	348,8
80,6	177	350,6
81,1	178	352,4
81,7	179	354,2
82,2	180	356
82,8	181	357,8
83,3	182	359,6
83,9	183	361,4
84,4	184	363,2



Trane optimizes the performance of homes and buildings around the world. A business of Ingersoll Rand, the leader in creating and sustaining safe, comfortable and energy efficient environments, Trane offers a broad portfolio of advanced controls and HVAC systems, comprehensive building services, and parts. For more information, visit www.trane.com.br

Trane has a policy of continuous product and product data improvement and reserves the right to change design and specifications without notice.

© 2015 Trane
All rights reserved
PKG-SVN002F-EN November 2015
Supersedes PKG-SVN002E-EN December 2014

We are committed to environmentally friendly
printing practices that reduce waste.

