



Installation, Operation, and Maintenance

Split System

Cooling Condensers — 20 to 120 Tons

Remote Chillers — 20 to 120 Tons

RAUJ-C20
RAUJ-C25
RAUJ-C30
RAUJ-C40
RAUJ-C50
RAUJ-C60
RAUJ-C80
RAUJ-D10
RAUJ-D12



▲ SAFETY WARNING

Only qualified personnel should install and service the equipment. The installation, starting up, and servicing of heating, ventilating, and air-conditioning equipment can be hazardous and requires specific knowledge and training. Improperly installed, adjusted or altered equipment by an unqualified person could result in death or serious injury. When working on the equipment, observe all precautions in the literature and on the tags, stickers, and labels that are attached to the equipment.



Introduction

Read this manual thoroughly before operating or servicing this unit.

Warnings, Cautions, and Notices

Safety advisories appear throughout this manual as required. Your personal safety and the proper operation of this machine depend upon the strict observance of these precautions.

The three types of advisories are defined as follows:



Indicates a potentially hazardous situation which, if not avoided, could result in death or serious injury.



Indicates a potentially hazardous situation which, if not avoided, could result in minor or moderate injury. It could also be used to alert against unsafe practices.



Indicates a situation that could result in equipment or property-damage only accidents.

Important Environmental Concerns

Scientific research has shown that certain man-made chemicals can affect the earth's naturally occurring stratospheric ozone layer when released to the atmosphere. In particular, several of the identified chemicals that may affect the ozone layer are refrigerants that contain Chlorine, Fluorine and Carbon (CFCs) and those containing Hydrogen, Chlorine, Fluorine and Carbon (HCFCs). Not all refrigerants containing these compounds have the same potential impact to the environment. Trane advocates the responsible handling of all refrigerants-including industry replacements for CFCs and HCFCs such as saturated or unsaturated HFCs and HCFCs.

Important Responsible Refrigerant Practices

Trane believes that responsible refrigerant practices are important to the environment, our customers, and the air conditioning industry. All technicians who handle refrigerants must be certified according to local rules. For the USA, the Federal Clean Air Act (Section 608) sets forth the requirements for handling, reclaiming, recovering and recycling of certain refrigerants and the equipment that is used in these service procedures. In addition, some states or municipalities may have additional requirements that must also be adhered to for responsible management of refrigerants. Know the applicable laws and follow them.

⚠ WARNING

Proper Field Wiring and Grounding Required!

Failure to follow code could result in death or serious injury.

All field wiring **MUST** be performed by qualified personnel. Improperly installed and grounded field wiring poses **FIRE** and **ELECTROCUTION** hazards. To avoid these hazards, you **MUST** follow requirements for field wiring installation and grounding as described in NEC and your local/state/national electrical codes.

⚠ WARNING

Personal Protective Equipment (PPE) Required!

Failure to wear proper PPE for the job being undertaken could result in death or serious injury. Technicians, in order to protect themselves from potential electrical, mechanical, and chemical hazards, **MUST** follow precautions in this manual and on the tags, stickers, and labels, as well as the instructions below:

- Before installing/servicing this unit, technicians **MUST** put on all PPE required for the work being undertaken (Examples; cut resistant gloves/sleeves, butyl gloves, safety glasses, hard hat/bump cap, fall protection, electrical PPE and arc flash clothing). **ALWAYS** refer to appropriate Safety Data Sheets (SDS) and OSHA guidelines for proper PPE.
- When working with or around hazardous chemicals, **ALWAYS** refer to the appropriate SDS and OSHA/GHS (Global Harmonized System of Classification and Labelling of Chemicals) guidelines for information on allowable personal exposure levels, proper respiratory protection and handling instructions.
- If there is a risk of energized electrical contact, arc, or flash, technicians **MUST** put on all PPE in accordance with OSHA, NFPA 70E, or other country-specific requirements for arc flash protection, **PRIOR** to servicing the unit. **NEVER PERFORM ANY SWITCHING, DISCONNECTING, OR VOLTAGE TESTING WITHOUT PROPER ELECTRICAL PPE AND ARC FLASH CLOTHING. ENSURE ELECTRICAL METERS AND EQUIPMENT ARE PROPERLY RATED FOR INTENDED VOLTAGE.**

⚠ WARNING**Follow EHS Policies!**

Failure to follow instructions below could result in death or serious injury.

- All Trane personnel must follow the company's Environmental, Health and Safety (EHS) policies when performing work such as hot work, electrical, fall protection, lockout/tagout, refrigerant handling, etc. Where local regulations are more stringent than these policies, those regulations supersede these policies.
- Non-Trane personnel should always follow local regulations.

⚠ WARNING**R-410A Refrigerant under Higher Pressure than R-22!**

Failure to use proper equipment or components as described below, could result in equipment failing and possibly exploding, which could result in death, serious injury, or equipment damage.

The units described in this manual use R-410A refrigerant which operates at higher pressures than R-22. Use **ONLY** R-410A rated service equipment or components with these units. For specific handling concerns with R-410A, please contact your local Trane representative.

Copyright

This document and the information in it are the property of Trane, and may not be used or reproduced in whole or in part without written permission. Trane reserves the right to revise this publication at any time, and to make changes to its content without obligation to notify any person of such revision or change.

Trademarks

All trademarks referenced in this document are the trademarks of their respective owners.

Revision History

- Updated Chiller Unit Dimensions section to add dimensions of chiller mounting location.
- Miscellaneous edits in Dimensions and Weights, Installation Mechanical and Start-Up chapters.



Table of Contents

Model Number Description	7	Refrigerant Piping Components	46
20 to 60 Ton Units	7	Refrigerant Piping	49
80 to 120 Ton Units	8	Typical Field-Installed Evaporator Piping: Dual-Circuit Examples	51
General Information	9	Hot Gas Bypass for Commercial Comfort-Cooling Applications	52
Unit Inspection	9	Optional Pressure Gauges	52
Exterior Inspection	9	Final Refrigerant Pipe Connections	53
Inspection for Concealed Damage	9	Brazing Procedures	53
Repair	9	Leak Testing Procedure	54
Nameplates	9	Installation Mechanical — EVP	55
Unit Nameplate	9	EVP Chilled Water Piping Requirements	55
Compressor Nameplate	9	TXV for Remote Chiller	55
EVP Chiller — Applications Only	9	Typical Field-Installed EVP Chiller Evaporator Piping	55
Unit Protection	9	Remote EVP Chiller	56
Phase Monitor (1U3)	9	Water Treatment	56
Manual Motor Protectors (380V through 575V Only)	10	Water Flow Limits	56
Discharge Line Thermostat	10	Water Temperature Limits	56
Unit Description	10	Short Water Loops	56
General Data	12	Chilled Water Piping	57
Dimensions and Weights	14	Final Water Piping Connections	60
Unit Clearances	14	Installation Electrical	61
Unit Dimensions	16	Electrical	61
Unit Weights	39	Wiring Requirements	63
Installation Mechanical	40	Main Electrical Power Requirements	63
Location Requirements	40	Field Installed Control Wiring Requirements	63
Isolation	40	Low Voltage Wiring (AC & DC)	64
Foundation	40	Field Installed Power Wiring	64
Leveling the Unit	40	Field Installed Control Wiring	66
Rigging and Lifting	40	EVP Chiller Control	82
Unit Mounting	43	Operating Principles	86
Unit Isolation	44	Component Locations	86
Neoprene Isolators (20 to 60 Ton units)	44	Condenser Fans	86
Spring Isolators (20 to 120 Ton units)	45	Compressors	87
Installation	46	Compressor Junction Box	88
General Unit Requirements	46	Unit Operation	89
Refrigerant Piping Requirements	46	VAV W7100A Discharge Air Controller (7U11)	89

Economizer Cycle	90	Preliminary Expansion Valve Adjustment	107
Chilled Water Temperature Controller (6U11)	90	Adding Preliminary Charge	108
Thermostatic Expansion Valve	91	Compressor Start-Up(All Systems)	109
Condenser Fans	91	Motors Rotating Backward	112
Low Ambient Dampers	92	Subcooling	113
Compressor Crankcase Heaters	92	Measuring Superheat	113
Low Ambient Thermostats	93	Compressor Oil	113
Hot Gas Bypass Operation	93	Compressor Crankcase Heaters	113
Pre-Start	94	Compressor Sequencing	114
EVP Chiller Applications	94	Pressure Curves	114
System Evacuation Procedures	94	Final System Setup	116
Standing Vacuum Test	95	Maintenance	118
Discharge Air Controller Checkout (Honeywell W7100A)	96	Monthly Maintenance	118
Discharge Air Sensor Checkout (Honeywell Sensor)	98	Air Handling Equipment	118
Economizer Actuator Checkout	98	Condensing Unit	118
EVP Chiller Control Checkout (Honeywell W7100G)	99	Coil Cleaning	119
Chilled Water Sensor Checkout (Honeywell Sensor)	100	Microchannel Condenser Coil Repair and Replacement	119
Master Energy Control Checkout	101	EVP Remote Evaporator Chiller	119
Zone Thermostat Checkout (Honeywell T7067)	102	Water Strainer Maintenance	119
Discharge Air Sensor Checkout (Honeywell 6RT1)	102	EVP Evaporator Replacement	120
Voltage Imbalance	104	Water Loop	120
Electrical Phasing	104	Scroll Compressor	120
Start-Up	105	Operational Sounds	120
Low Ambient Damper Adjustment (Factory or Field Installed)	105	Failure Diagnosis and Replacement	120
EVP Chiller Applications	105	Refrigerant Evacuation and Charging	120
Freezestat Setting	105	Compressor Replacement	121
“Air Over” Evaporator Application	105	CSHD Compressors (20 to 60 Ton)	121
Verifying Proper Supply Fan Rotation	105	CSHN Compressors (80 to 120T)	121
System Airflow Measurement	106	Suction Line Filter	124
Measuring Airflow	106	Fuse Replacement Data	124
Alternate Method	106	Fall Restraint — Condenser Roof	125
		Warranty and Liability Clause	126
		Commercial Equipment Rated 20 Tons and Larger and Related Accessories	126
		Products Covered	126



Table of Contents

Wiring Diagrams 127



Model Number Description

20 to 60 Ton Units

Digit 1 — Unit Type

R = Remote Condenser

Digit 2 — Condenser

A = Air-Cooled

Digit 3 — System Type

U = Upflow

Digit 4 — Development Sequence

J = Third

Digit 5, 6, 7 — Nominal Capacity

C20 = 20 Tons

C25 = 25 Tons

C30 = 30 Tons

C40 = 40 Tons

C50 = 50 Tons

C60 = 60 Tons

Digit 8 — Voltage and Start Characteristics

D = 415/50/3 XL

E = 200/60/3 XL

F = 230/60/3 XL

4 = 460/60/3 XL

5 = 575/60/3 XL

9 = 380/50/3 XL

Digit 9 — System Controls

B = No System Control

E = Supply Air VAV Control

P = EVP Control

Digit 10 — Design Sequence

Factory Assigned

Digit 11 — Ambient Control

0 = Standard

1 = 0°F (Low Ambient Dampers)

Digit 12 — Agency Approval

0 = None

3 = cULus (60 Hz only)

Digit 13 — Disconnect Switch

0 = None

A = Non-Fused Disconnect Switch

Digit 14 — Hot-Gas Bypass Valve

0 = None

B = Hot-Gas Bypass Valve

Digit 15 — Suction Service Valve

0 = None

D = Suction Service Valve

Digit 16 — Pressure Gauges

0 = None

F = Pressure Gauges and Piping

Digit 17 — Return Air Sensor

0 = None

G = Return Air Sensor

Digit 18 — Corrosion Protected Condenser Coil

0 = None

J = Corrosion Protected Condenser Coil

Digit 19 — Options

0 = None

C = Remote Chiller Evaporator and Install Kit

T = Flow Switch (EVP Control Only)

Digit 20 — Isolators

1 = Spring Isolator

2 = Neoprene Isolators

Note: The service digit for each model number contains 20 digits. All 20 digits must be referenced.



Model Number Description

80 to 120 Ton Units

Digit 1 — Unit Type

R = Remote Condenser

Digit 2 — Condenser

A = Air-Cooled

Digit 3 — System Type

U = Upflow

Digit 4 — Development Sequence

J = Third

Digit 5, 6, 7 — Nominal Capacity

C80 = 80 Tons

D10 = 100 Tons

D12 = 120 Tons

Digit 8 — Voltage and Start Characteristics

E = 200/60/3 XL

F = 230/60/3 XL

4 = 460/60/3 XL

5 = 575/60/3 XL

***** = 380/50/3 XL

***** = 415/50/3 XL

Digit 9 — System Controls

B = No System Control

E = Supply Air VAV Control

P = EVP Control

Digit 10 — Design Sequence

Factory Assigned

Digit 11 — Ambient Control

0 = Standard

1 = 0°F (Low Ambient Dampers)

Digit 12 — Agency Approval

0 = None

3 = cULus (60 Hz only)

Digit 13 — Circuits

2 = Dual

Digit 14 — Hot-Gas Bypass Valve

0 = None

B = Hot-Gas Bypass Valve

Digit 15 — Suction Service Valve

0 = None

D = Suction Service Valve

Digit 16 — Pressure Gauges

0 = None

F = Pressure Gauges and Piping

Digit 17 — Corrosion Protected Condenser Coil

0 = None

J = Corrosion Protected Condenser Coil

Digit 18 — Isolators

0 = None

1 = Spring Isolator

Digit 19 —

C = Remote Chiller Evap and Install Kit

3 = Flow Switch (EVP Controls Only)

Notes:

1. The service digit for each model number contains 19 digits. All 19 digits must be referenced.
2. * = Design special.



General Information

Unit Inspection

To protect against loss due to damage incurred in transit, perform inspection immediately upon receipt of the unit.

Exterior Inspection

If the job site inspection reveals damage or material shortages, file a claim with the carrier immediately. Specify the type and extent of the damage on the bill of lading before signing. Notify the appropriate sales representative.

Important: Do not proceed with installation of a damaged unit without sales representative's approval.

- Visually inspect the complete exterior for signs of shipping damages to unit or packing material.
- Verify that the nameplate data matches the sales order and bill of lading.
- Verify that the unit is properly equipped and there are no material shortages.
- Verify that the power supply complies with the unit nameplate and electric heater specifications.

Inspection for Concealed Damage

Visually inspect the components for concealed damage as soon as possible after delivery and before it is stored.

Do NOT walk on the sheet metal base pans. Bridging between the unit's main supports may consist of multiple 2 by 12 boards or sheet metal grating.

⚠ WARNING

No Step Surface!
Failure to follow instruction below could result in death or serious injury.
Do not walk on the sheet metal drain pan. Walking on the drain pan could cause the supporting metal to collapse and result in the operator/technician falling.

If concealed damage is discovered:

- Notify the carrier's terminal of the damage immediately by phone and by mail.
- Concealed damage must be reported within 15 days.
- Request an immediate, joint inspection of the damage with the carrier and consignee.
- Stop unpacking the unit.
- Do not remove damaged material from receiving location.
- Take photos of the damage, if possible.

- The owner must provide reasonable evidence that the damage did not occur after delivery.

Repair

Notify the appropriate sales representative before arranging unit installation or repair.

Important: Do not repair unit until the damage has been inspected by the carrier's representative.

Nameplates

Unit Nameplate

One Mylar unit nameplate is located on the outside upper right corner of the control panel door. It includes the unit model number, serial number, electrical characteristics, weight, refrigerant charge, as well as other pertinent unit data. A small metal nameplate with model number, serial number, and unit weight is located just above the Mylar nameplate, and a third nameplate is located on the inside of the control panel door.

When ordering replacement parts or requesting service, be sure to refer to the specific model number, serial number, and DL number (if applicable) stamped on the unit nameplate.

Compressor Nameplate

The nameplate for the scroll compressors is located on the lower housing of the compressor.

EVP Chiller — Applications Only

If ordered with remote EVP chiller kit, piping components ship in condenser section. The heat exchanger ships separately. Location of nameplate depends on size.

- 20-30 ton chiller: same side as water connections near center left.
- 40-120 ton chiller: same side as water connections near bottom.

To view nameplate, raise insulation flap over nameplate. Replace and retape insulation flap after viewing.

Unit Protection

Phase Monitor (1U3)

The unit is equipped with a phase monitor in the control box. The phase monitor will protect against phase loss, imbalance and reversal of the line voltage. If a fault occurs, the red LED will energize. While the fault condition is present the phase monitor interrupts



General Information

the 115V control circuit. If no faults are observed, a green LED will be energized.

Manual Motor Protectors (380V through 575V Only)

Manual motor protectors will be used as branch circuit protection for compressors. These devices are capable of providing both overload and short-circuit protection.

Before operating, the manual motor protector must be switched with the rotary on/off switch to the "ON" position and the overload setpoint dial must be set to the appropriate rating of the motor.

Important: *In order to avoid nuisance trips, the overload setpoint dial must be adjusted to the following calculated value:*
$$\text{Overload Setting} = (\text{Compressor RLA}) \times 1.12$$

Figure 1. Compressor protection module

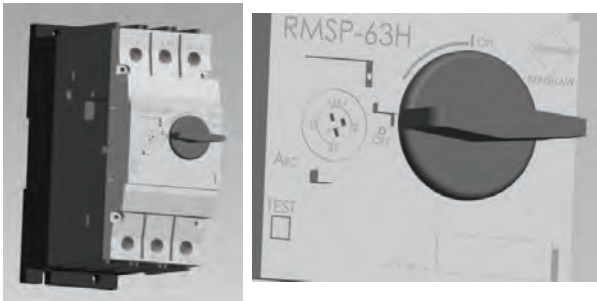

The 80 to 120 ton CSHN compressors include a preinstalled motor protection module mounted and wired into the compressor terminal box. This device provides protection against the following:

- Overcurrent caused by overloading (sensed by motor temperature)
- Overheating of the motor
- Phase loss/reversal
- Phase sequence

The motor protector includes a motor protection module and Positive Temperature Coefficient thermistors (PTC) embedded in the motor windings. The close contact between the thermistors and windings ensures a very low level of thermal inertia.

Discharge Line Thermostat

The first compressor on each circuit is equipped with a Discharge Line Thermostat. If the temperature of the line exceeds 230°F the thermostat interrupts the 115V control circuit for the compressors and all the compressors on the circuit will de-energize. Once the temperature drops below 180°F the thermostat will close and allow the compressor to be energized.

Unit Description

All air cooled condensing units are designed for outdoor installations with vertical air discharge. These units may be installed on a flat roof or placed on a concrete slab at ground level.

Before shipment, each unit is leak-tested, evacuated, a nitrogen holding charge is added, and the controls are tested for proper operation.

The condenser coils are all-aluminum microchannel design. Corrosion protected condenser coils are a standard option. Louvered condenser grilles for coil protection are standard. Direct-drive, vertical discharge condenser fans are provided with built-in current and overload protection.

For "Ship with" items, see the following figures.

If low ambient operation is required, low ambient dampers are available as a field or factory installed option.

Units may be ordered with one of the following options:

- No System Controls (Field provided controls required)
- Constant Volume Controls
- Supply Air Temperature Control (VAV applications)
- EVP Chiller Controls

Basic unit components include:

- Manifolded scroll compressors
- Condenser coils
- Condenser fans (number based on unit size)
- Discharge service valve (one per circuit)

Figure 2. Component layout and 'ship-with' locations – 20 to 60 ton units:

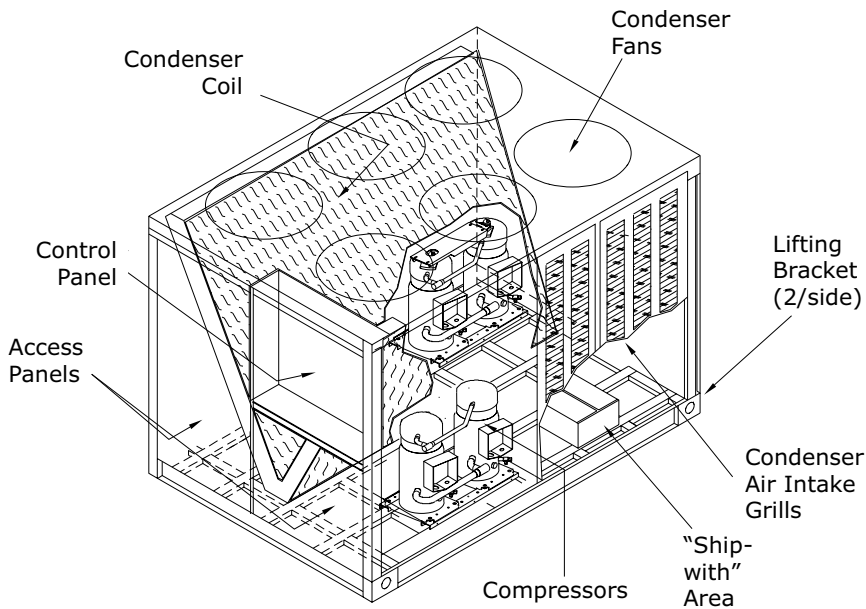
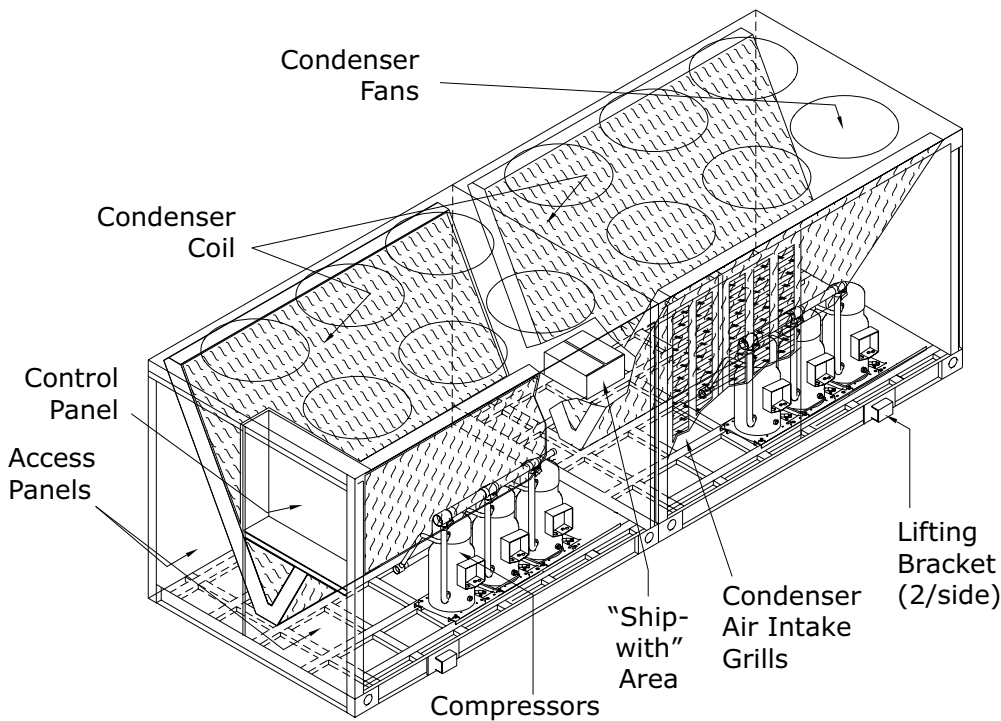

Figure 3. Component layout and 'ship-with' locations – 80 to 120 ton units:



¹ 60 ton unit shown
² 120 ton unit shown



General Information

General Data

Table 1. General data – RAUJ condensing units

Unit Size (tons)		20	25	30	40	50	60	80	100	120
Compressor Data										
Type		Scroll								
Number of Refrigerant Circuits		1	1	1	2	2	2	2	2	2
Manifolded Compressor sizes ^(a)	Tons	10-10	10-13.5	15-15	10-10	11.5-13.5	15-15	15-15-15	15-15-20	20-20-20
Unit Capacity Steps	%	100-50	100-42	100-50	100-75-50-25	100-73-46-23	100-75-50-25	100-83-66-50-33-17	100-80-60-45-30-15	100-83-66-50-33-17
Condenser Fan Data										
Type/Drive Type		Prop/Direct								
Qty		2	3	3	4	6	6	8	12	12
Diameter	in	26	26	26	26	26	26	26	26	26
Power/motor	hp	1.0	1.0	1.0	1.0	1.0	1.0	1.0	1.0	1.0
Nominal Total Airflow	cfm	14600	20700	20700	26790	36890	40490	56490	73890	76280
Condenser Coil Data										
Type		Microchannel								
Number of Coils		2	2	2	2	2	2	4	4	4
Size	in	42x71	42x71	42x71	59x71	51x96	51x96	59x71	51x96	64x96
Face Area	ft ²	41.4	41.4	41.4	58.2	68.0	68.0	116.4	136.0	170.7
Rows/Fin Per Ft.		1/240	1/240	1/240	1/240	1/240	1/240	1/240	1/240	1/240
Storage Capacity ^(b)	lbs	18.7	18.7	18.7	23.5	25.0	25.0	47.1	50.0	62.9
Refrigerant Data^(c)										
Type		R-410A								
Operating Charge ^(d)	lbs	11.9	11.8	11.8	22.7	23.4	23.8	57.1	59.1	65.3
Outdoor Air Temperature for Mechanical Cooling										
Standard Ambient Operating Range ^(e)	°F	40-125	40-125	40-125	40-125	40-125	40-125	40-125	40-125	40-125
Low Ambient Option	°F	0-125	0-125	0-125	0-125	0-125	0-125	0-125	0-125	0-125

^(a) Circuit 1 compressor manifold sizes shown. For units with 2 circuits, compressor manifold set is the same for circuit 1 and 2.

^(b) Condenser storage capacity is given at conditions of 95°F outdoor temperature, and 95% full.

^(c) Refer to Refrigerant Piping in the Application Considerations section. Condensing units are shipped with nitrogen holding charge only.

^(d) Operating charge is approximate for condensing unit only, and does not include charge for low side or interconnecting lines. Condensing units are shipped with a nitrogen holding charge only.

^(e) Maximum operating ambient for EVP remote chillers is 115°F.

Table 2. Altitude correction multiplier for capacity

Configuration	Altitude (ft.)				
	2,000	4,000	6,000	8,000	10,000
Condensing Unit Only	0.982	0.960	0.933	0.902	0.866
Condensing Unit / Air Handling Unit Combination	0.983	0.963	0.939	0.911	0.881
Condensing Unit With Evaporator	0.986	0.968	0.947	0.921	0.891

Dimensions and Weights

Unit Clearances

The figure below illustrates the minimum operating and service clearances for either a single, multiple, or pit application. These clearances are the minimum distances necessary to assure adequate serviceability, cataloged unit capacity, and peak operating efficiency.

Important: Providing less than the recommended clearances could result in condenser coil starvation or recirculation of hot condenser air.

Locate the unit as close to the applicable system support equipment as possible to minimize refrigerant piping lengths.

Allow adequate clearance for water and refrigerant piping connections, space to perform service procedures, i.e. read gauges, thermometers, and operate water system valves.

Note: EVP braze plate chiller installation must also allow adequate clearance as described above.

Note: EVP chiller is intended for indoor application. If a sub-freezing location is required, contact Trane for installation precautions required to prevent damage.

Figure 4. Unit clearances

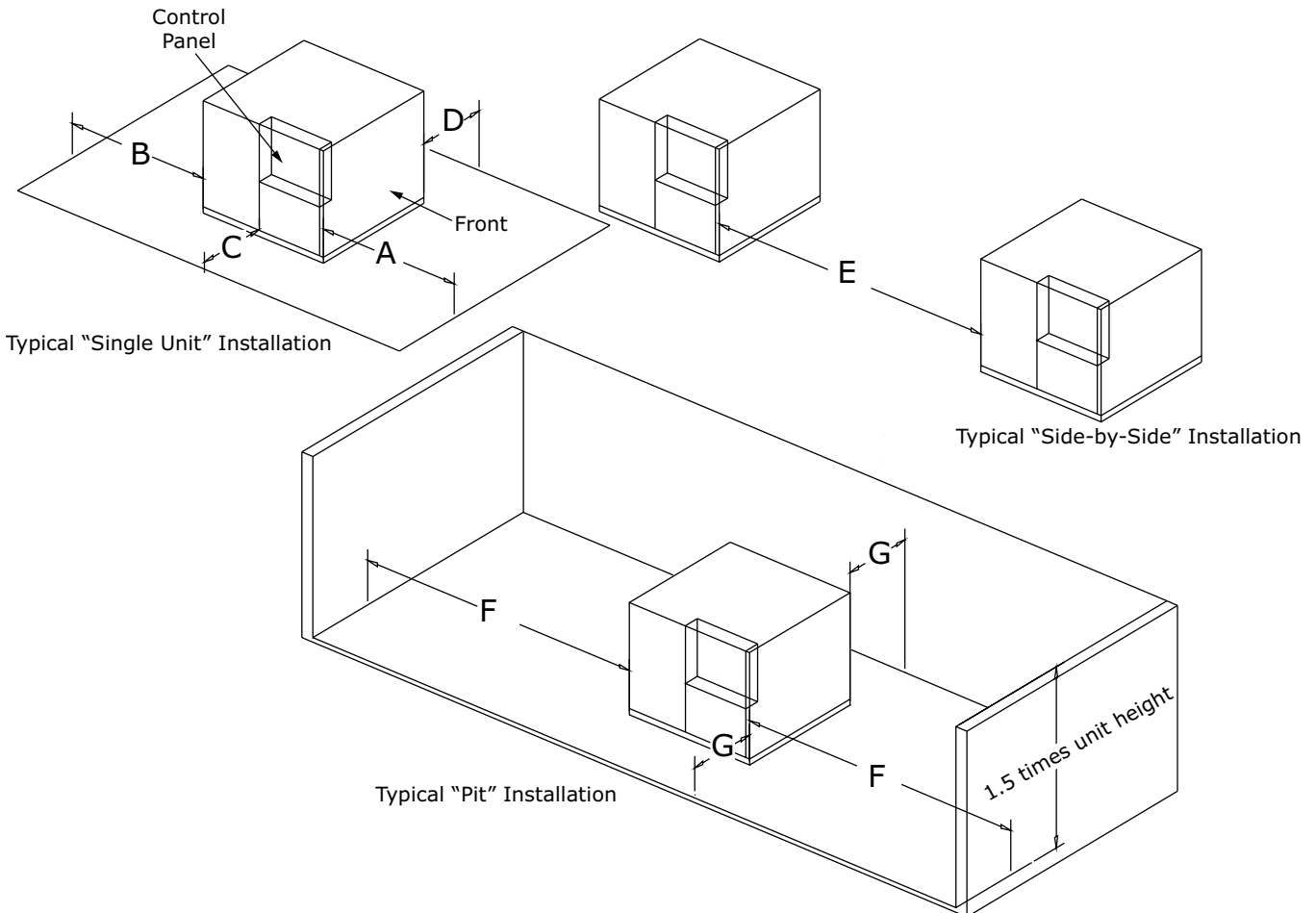

Table 3. Unit clearances

Dimension	Location	Clearance (in)	
		20 to 60 tons	80 to 120 tons
A	Front	72	96
B	Back	72	96
C	Left (control panel side)	42	48
D	Back	42	48
E	Distance between units (side-by-side)	192	192
F	Pit installation - front and back	192	192
G	Pit installation - sides	48	48



Dimensions and Weights

Unit Dimensions

Figure 5. Air-cooled condensing unit – 20 ton

NOTES:

1. SEE CONNECTION DRAWING FOR CONNECTION LOCATION AND SIZES.
2. LOW AMBIENT DAMPER ONLY COMES WITH SELECTED UNIT .
3. FRONT OF UNIT CLEARANCE 72" . BACK OF UNIT CLEARANCE 72" . LEFT AND RIGHT SIDE OF UNIT CLEARANCE 42" .

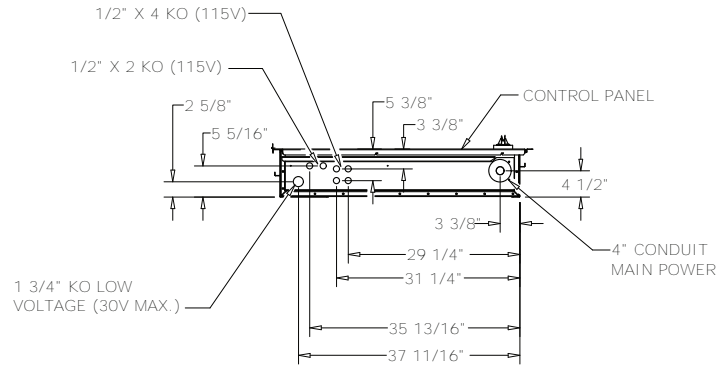
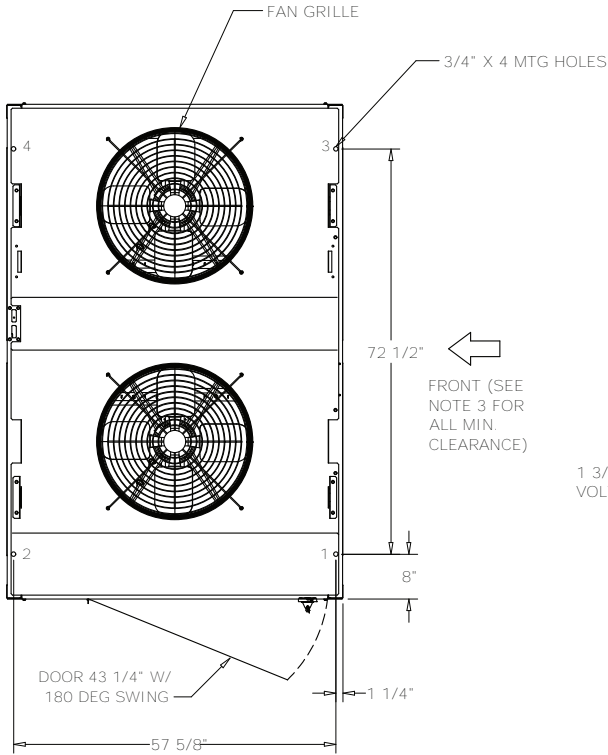

DETAIL A

CONTROL BOX BOTTOM

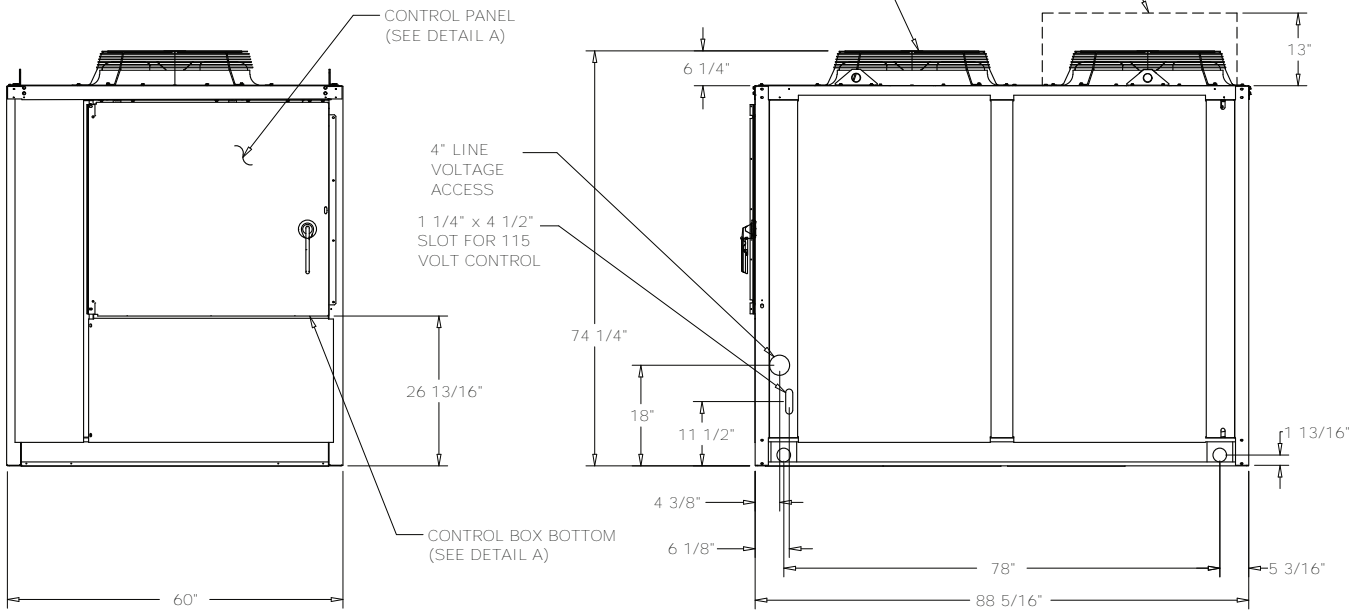
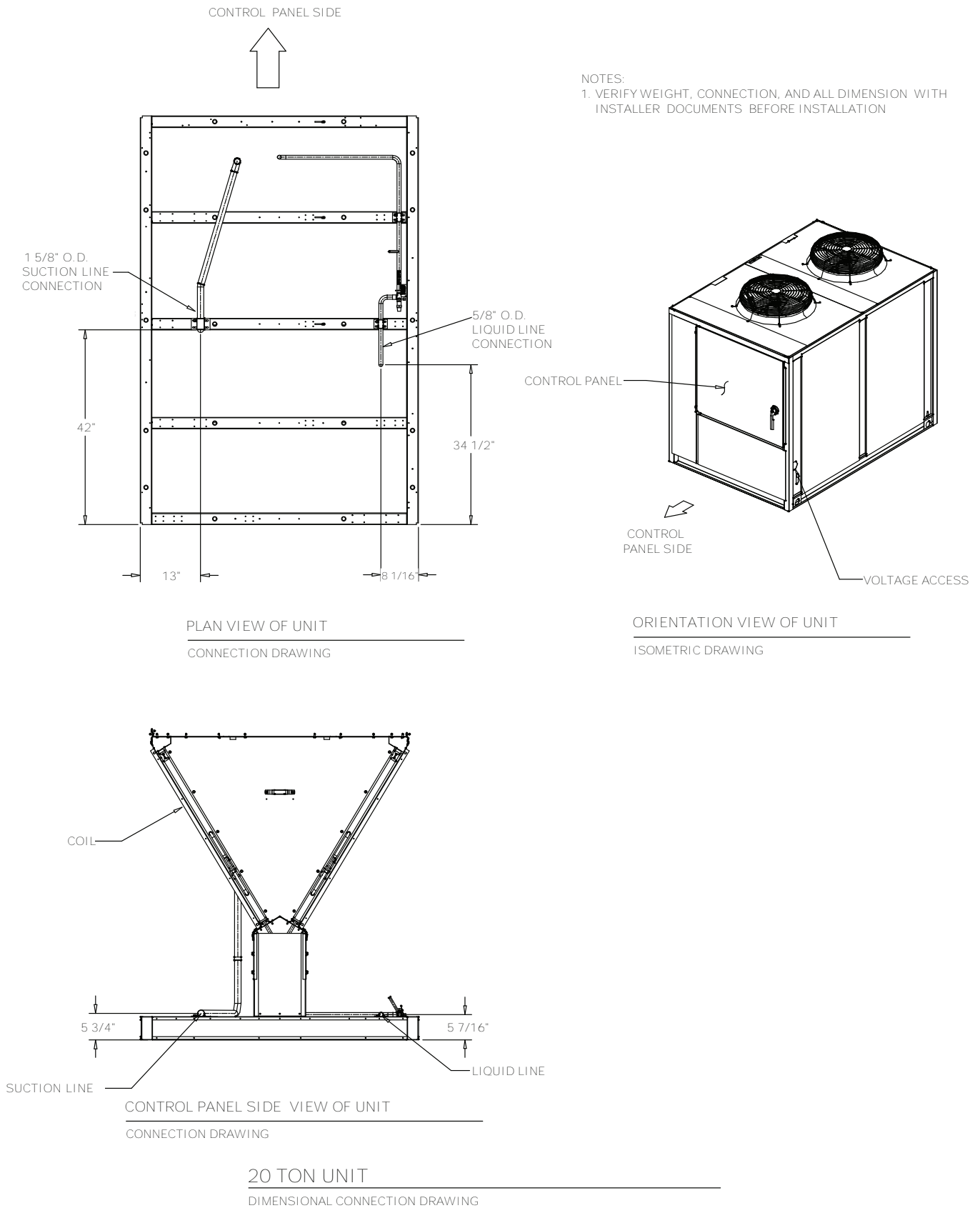

Figure 6. Air-cooled condensing unit connections – 20 ton





Dimensions and Weights

Figure 7. Air-cooled condensing unit — 25 and 30 ton

NOTES:

1. SEE CONNECTION DRAWING FOR CONNECTION LOCATION AND SIZES.
2. LOW AMBIENT DAMPER ONLY COMES WITH SELECTED UNIT .
3. FRONT OF 20 AND 30 UNIT CLEARANCE 72" . BACK OF UNIT CLEARANCE 72".
LEFT AND RIGHT SIDE OF 20 AND 30 UNIT CLEARANCE 42".

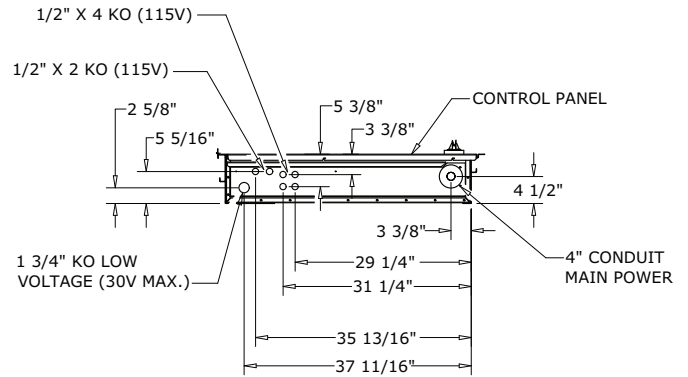
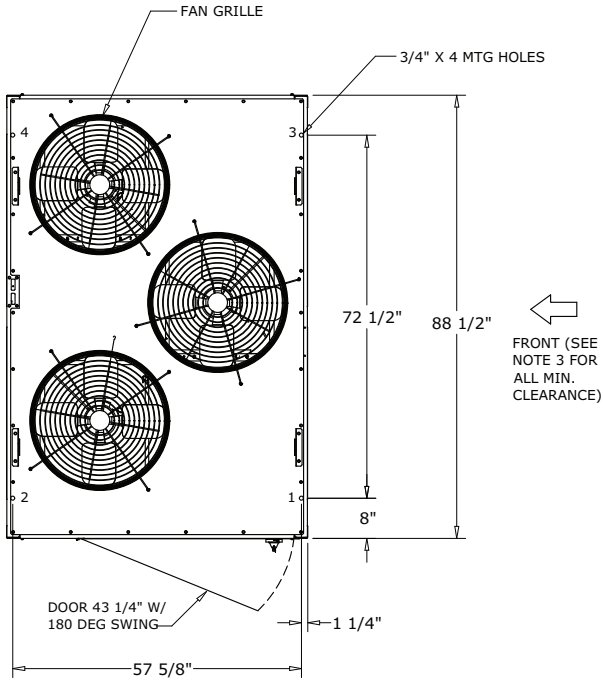

DETAIL A

CONTROL BOX BOTTOM

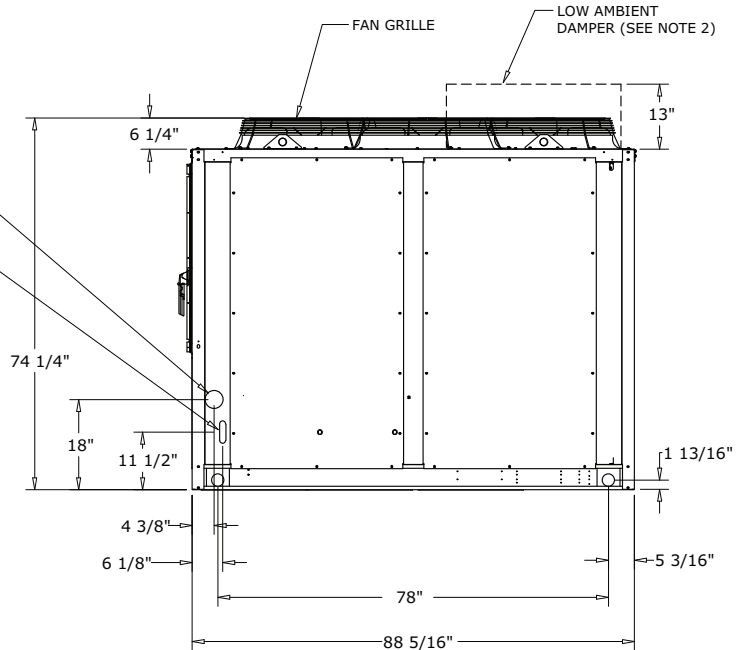
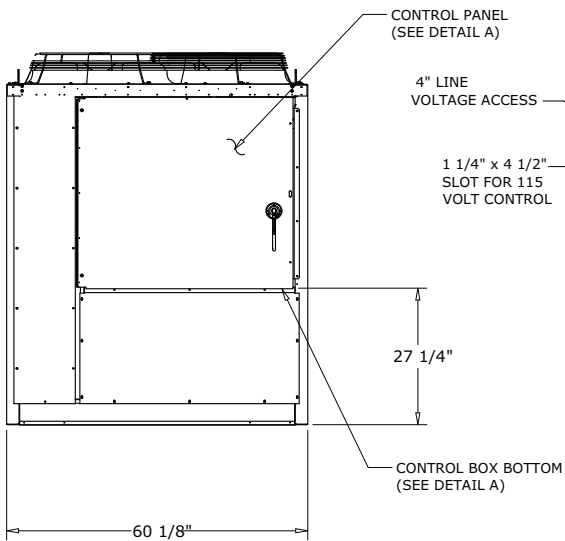
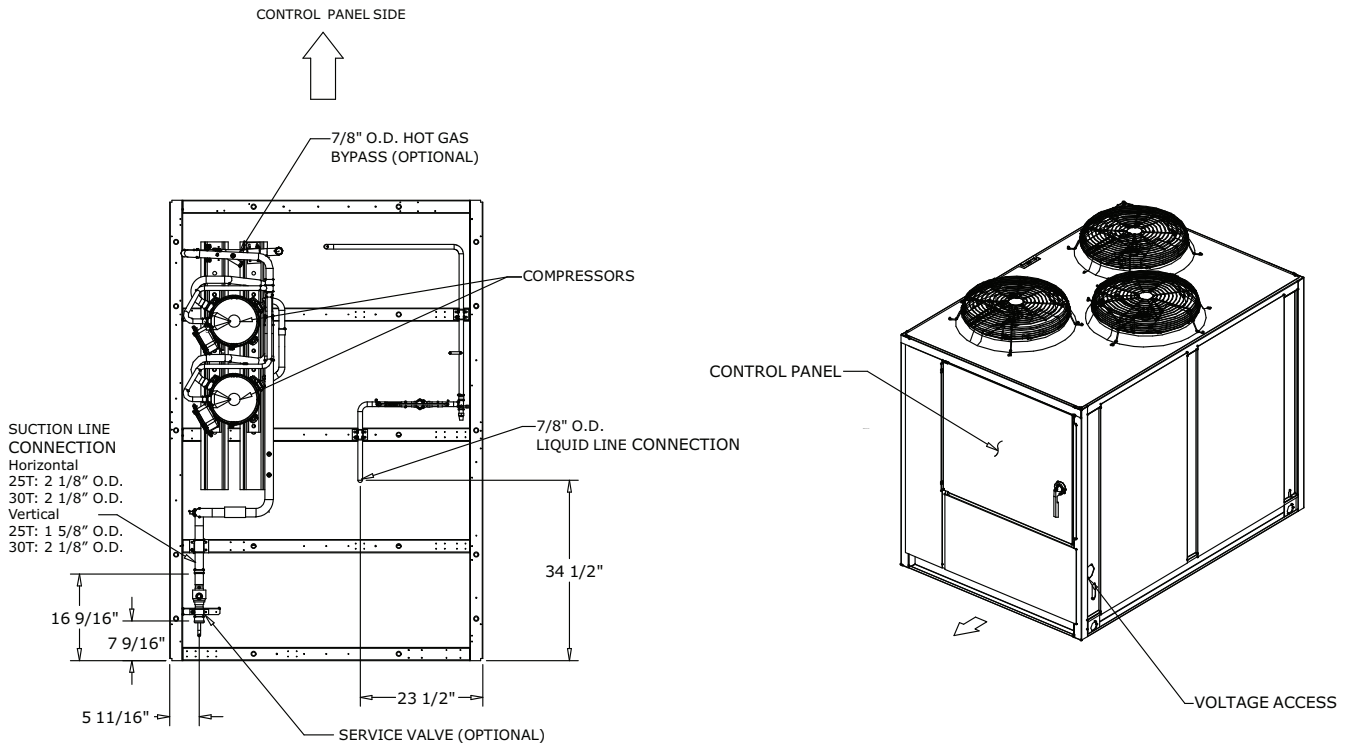
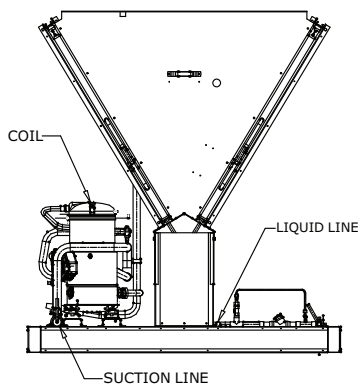

Figure 8. Air-cooled condensing unit connections – 25 and 30 tons

NOTES:
 1. VERIFY WEIGHT, CONNECTION, AND ALL DIMENSION WITH INSTALLER DOCUMENTS BEFORE INSTALLATION



PLAN VIEW OF UNIT
 CONNECTION DRAWING



CONTROL PANEL SIDE VIEW OF UNIT
 CONNECTION DRAWING

ORIENTATION VIEW OF UNIT
 ISOMETRIC DRAWING

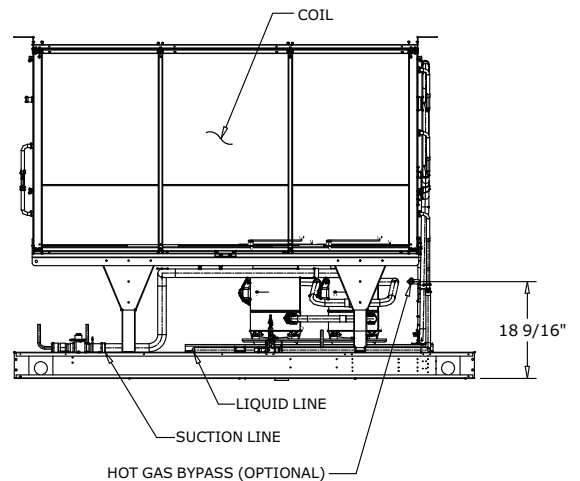

BACK VIEW OF UNIT
 CONNECTION DRAWING

25 - 30 TON UNIT
 DIMENSIONAL CONNECTION DRAWING



Dimensions and Weights

Figure 9. Air-cooled condensing unit — 40 ton

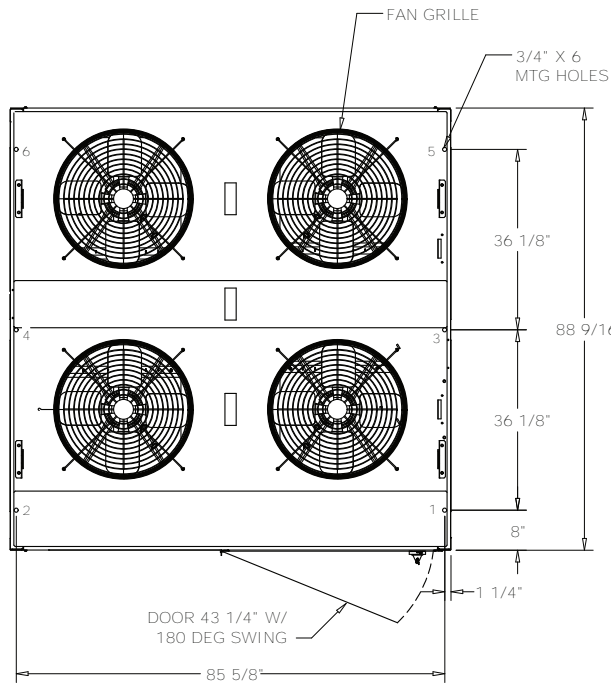

NOTES:

1. SEE CONNECTION DRAWING FOR CONNECTION LOCATION AND SIZES.
2. LOW AMBIENT DAMPER ONLY COMES WITH SELECTED UNIT .
3. FRONT AND BACK OF UNIT CLEARANCE 72" . LEFT AND RIGHT SIDE OF UNIT CLEARANCE 42" .

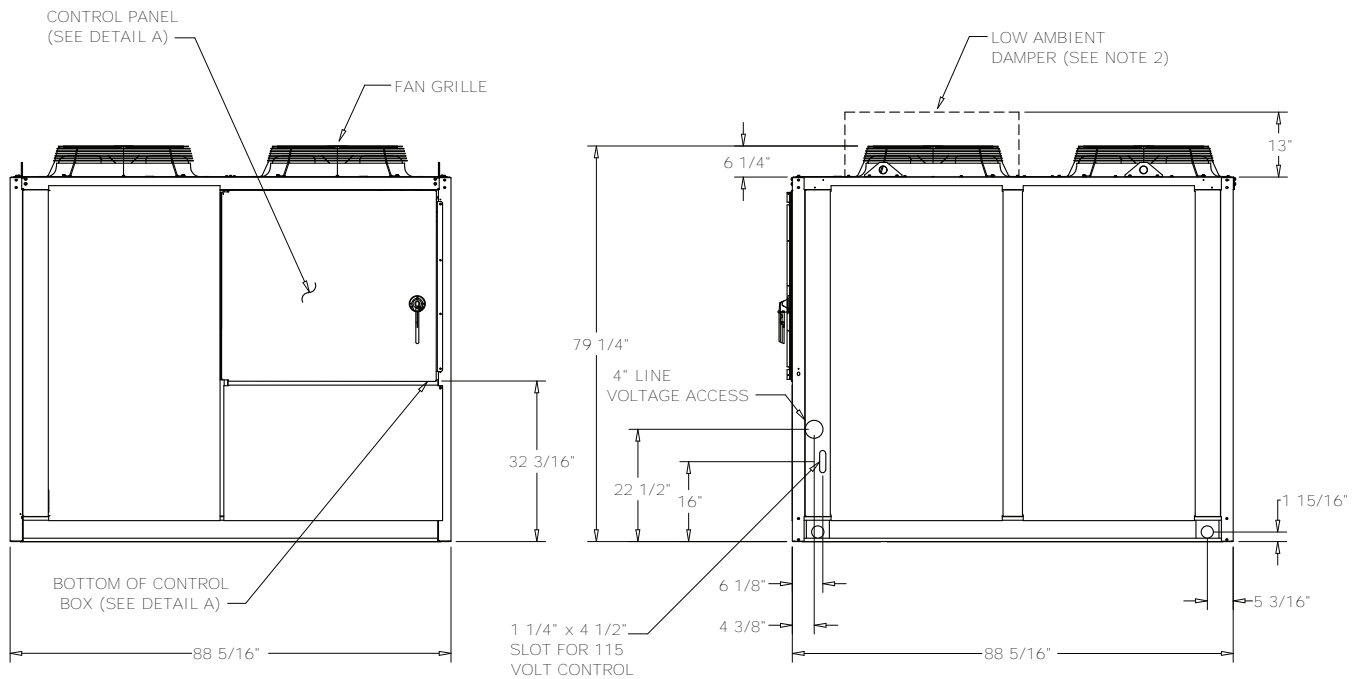
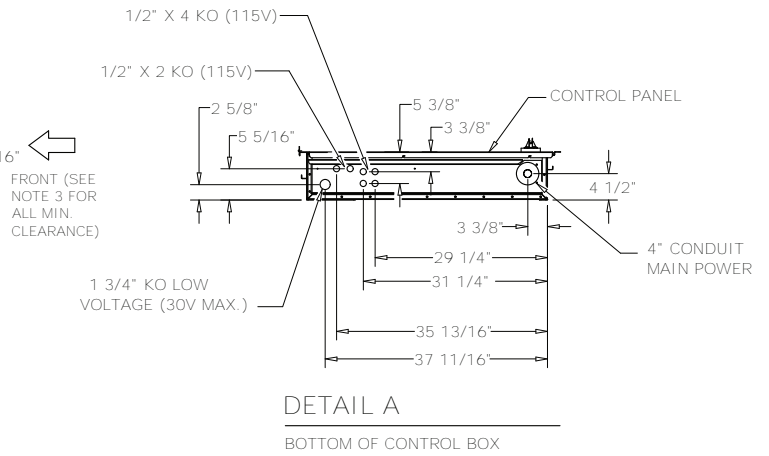
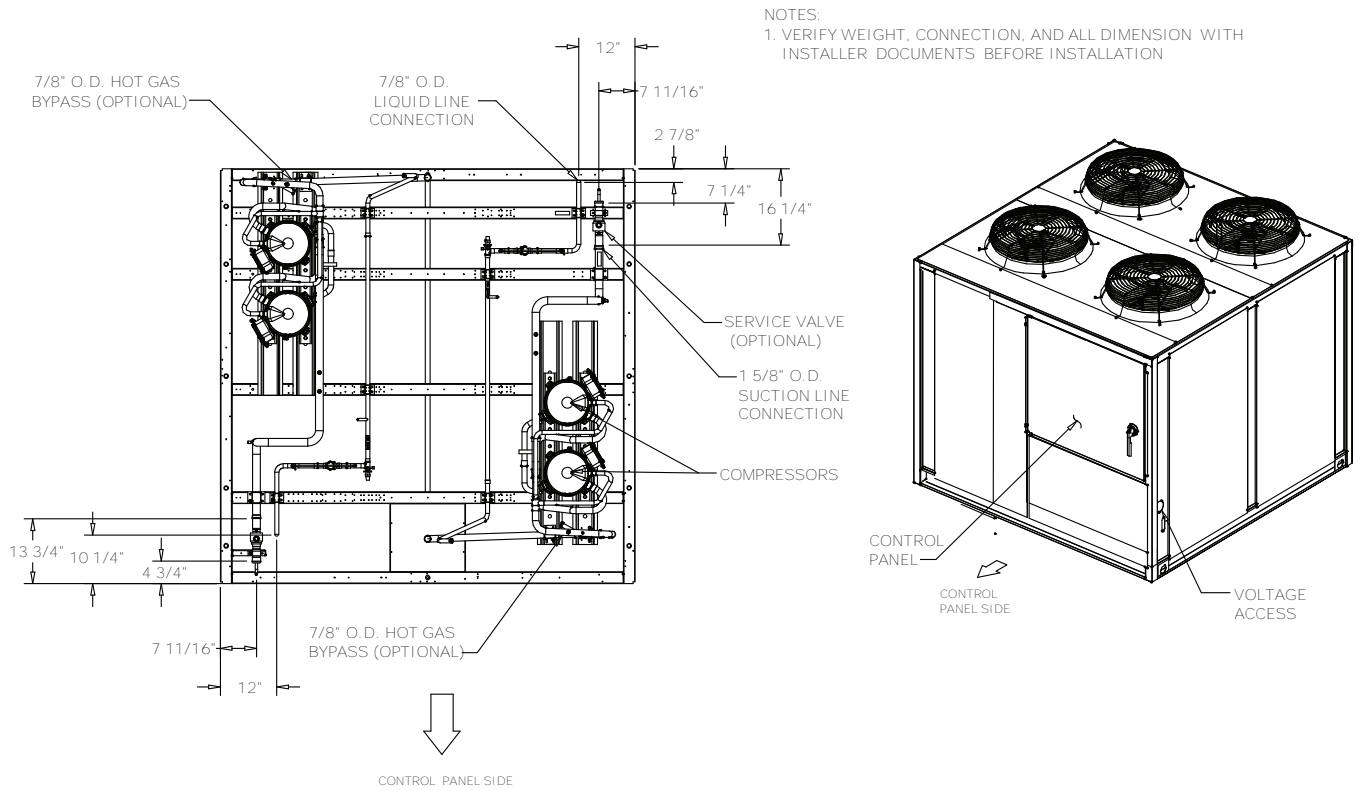

Figure 10. Air-cooled condensing unit connections — 40 ton



NOTES:
1. VERIFY WEIGHT, CONNECTION, AND ALL DIMENSION WITH INSTALLER DOCUMENTS BEFORE INSTALLATION

PLAN VIEW OF UNIT
CONNECTION DRAWING

ORIENTATION VIEW OF UNIT
ISOMETRIC DRAWING

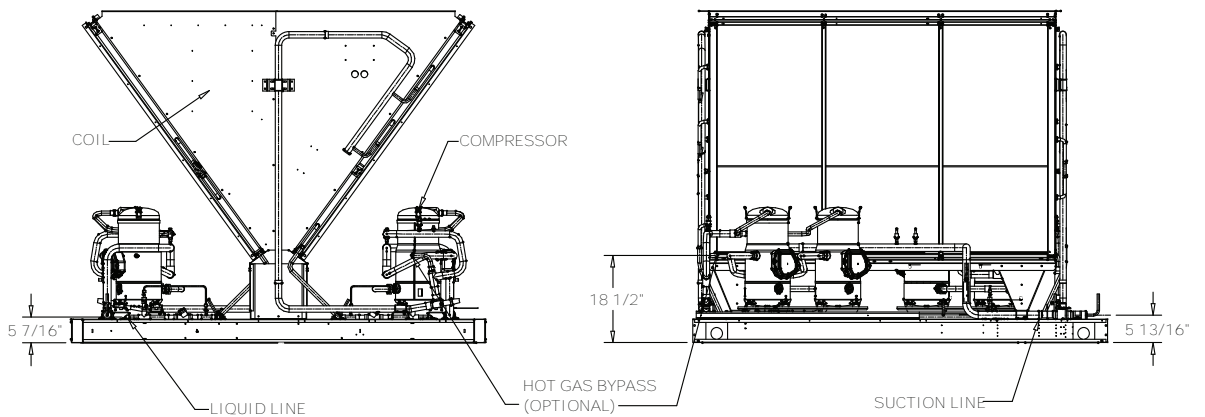

CONTROL PANEL SIDE VIEW OF UNIT
CONNECTION DRAWING

BACK VIEW OF UNIT
CONNECTION DRAWING

40 TON UNIT
DIMENSIONAL CONNECTION DRAWING



Dimensions and Weights

Figure 11. Air-cooled condensing unit — 50 ton

NOTES:

1. SEE CONNECTION DRAWING FOR CONNECTION LOCATION AND SIZES.
2. LOW AMBIENT DAMPER ONLY COMES WITH SELECTED UNIT .
3. FRONT AND BACK OF UNIT CLEARANCE 72" . LEFT AND RIGHT SIDE OF UNIT CLEARANCE 42" .

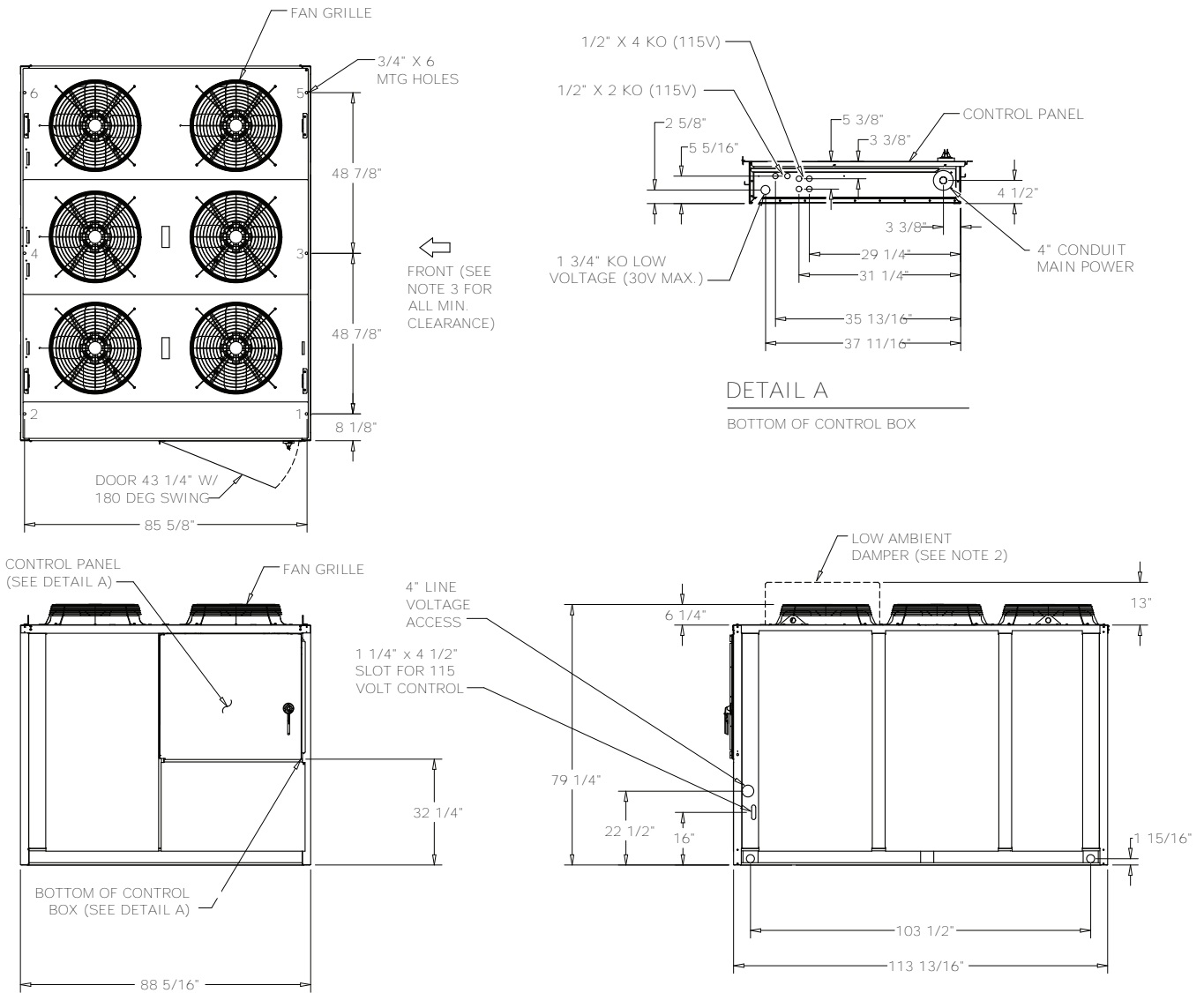
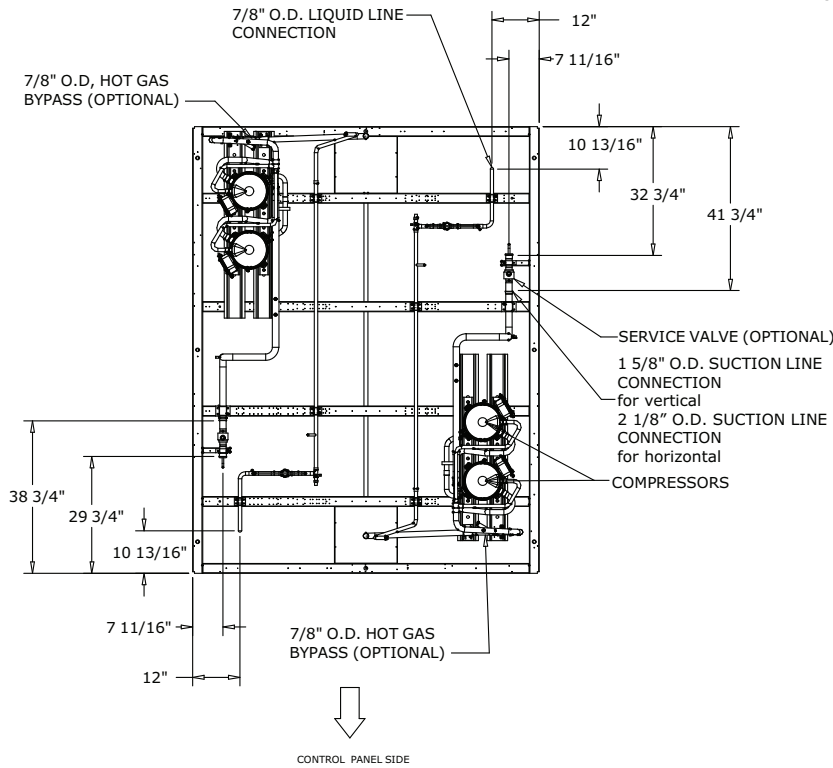
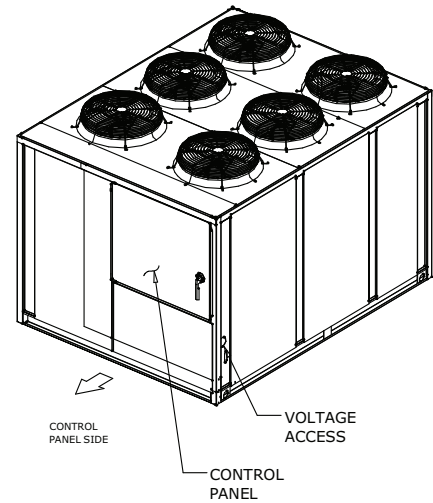

Figure 12. Air-cooled condensing unit connections — 50 ton

NOTES:
1. VERIFY WEIGHT, CONNECTION, AND ALL DIMENSION WITH INSTALLER DOCUMENTS BEFORE INSTALLATION



PLAN VIEW OF UNIT
CONNECTION DRAWING



ORIENTATION VIEW OF UNIT
ISOMETRIC DRAWING

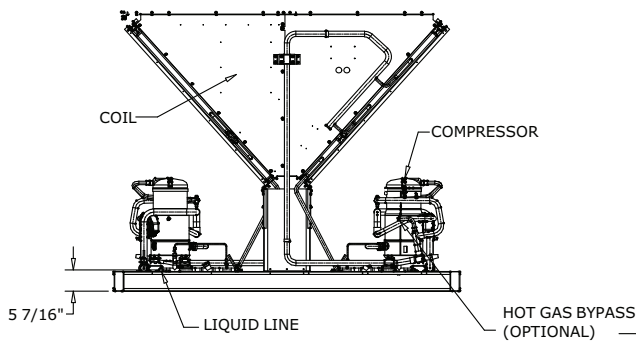

CONTROL PANEL SIDE VIEW OF UNIT
CONNECTION DRAWING

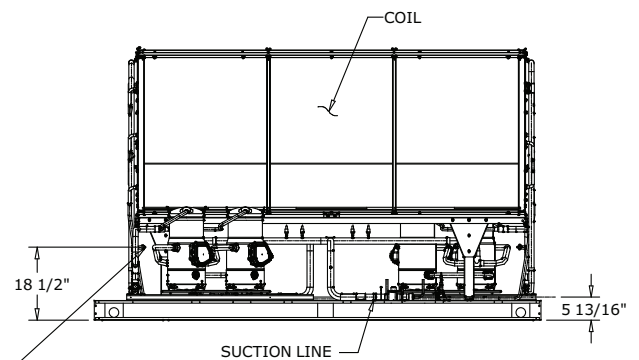

BACK VIEW OF UNIT
CONNECTION DRAWING

50 TON UNIT
DIMENSIONAL CONNECTION DRAWING



Dimensions and Weights

Figure 13. Air-cooled condensing unit — 60 ton

NOTES:

1. SEE CONNECTION DRAWING FOR CONNECTION LOCATION AND SIZES.
2. LOW AMBIENT DAMPER ONLY COMES WITH SELECTED UNIT.
3. FRONT AND BACK OF UNIT CLEARANCE 72". LEFT AND RIGHT SIDE OF UNIT CLEARANCE 42".

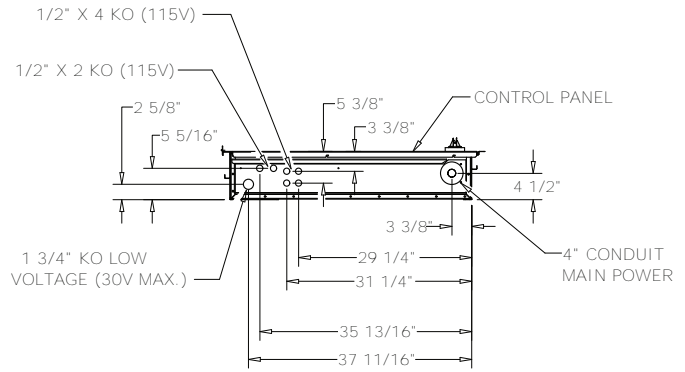
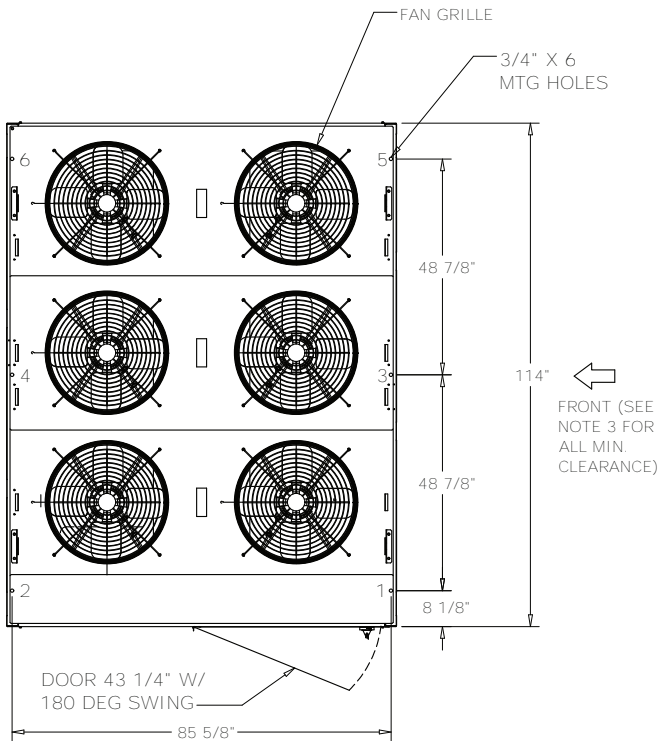

DETAIL A
BOTTOM OF CONTROL BOX

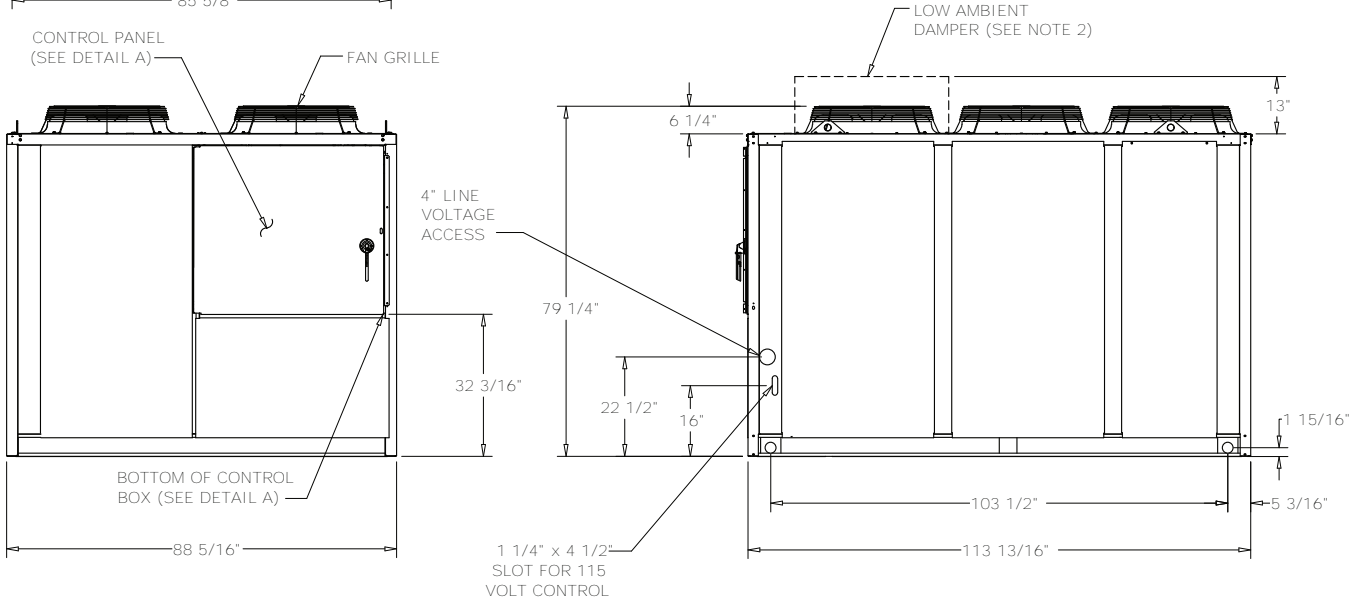
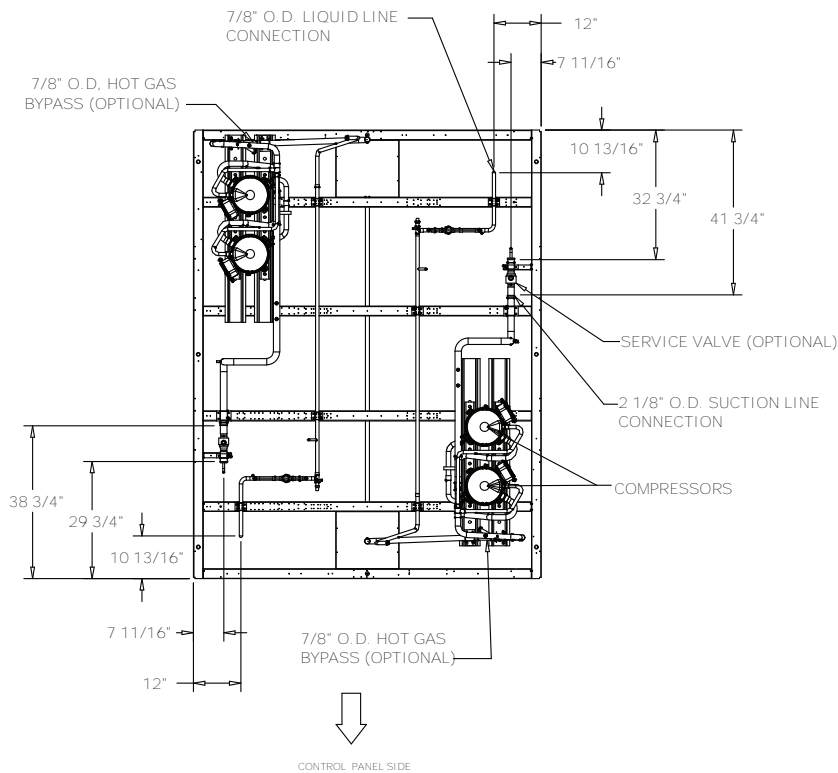
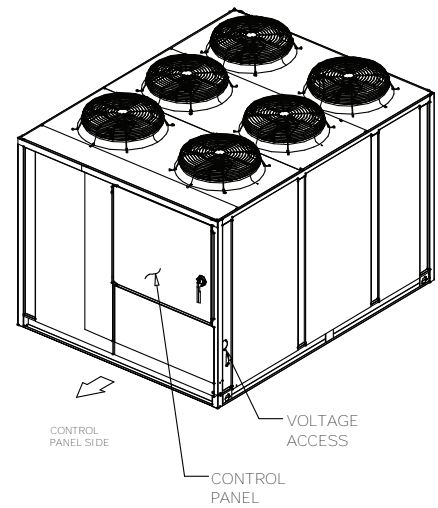

Figure 14. Air-cooled condensing unit connections — 60 ton

NOTES:
1. VERIFY WEIGHT, CONNECTION, AND ALL DIMENSION WITH INSTALLER DOCUMENTS BEFORE INSTALLATION



PLAN VIEW OF UNIT
CONNECTION DRAWING



ORIENTATION VIEW OF UNIT
ISOMETRIC DRAWING

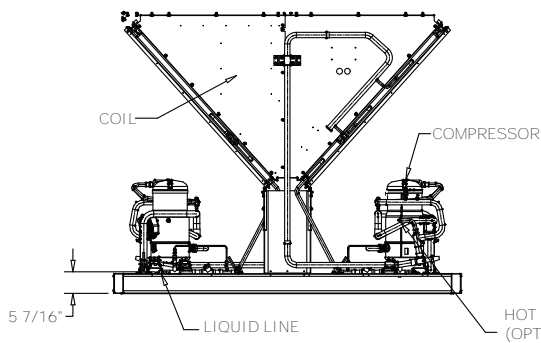

CONTROL PANEL SIDE VIEW OF UNIT
CONNECTION DRAWING

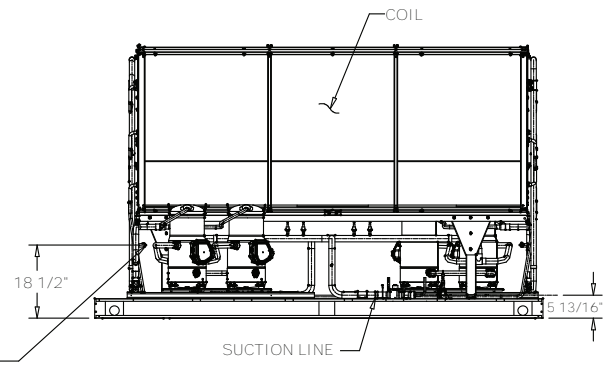

BACK VIEW OF UNIT
CONNECTION DRAWING

60 TON UNIT
DIMENSIONAL CONNECTION DRAWING

Dimensions and Weights

Figure 15. Air-cooled condensing unit — 80 ton

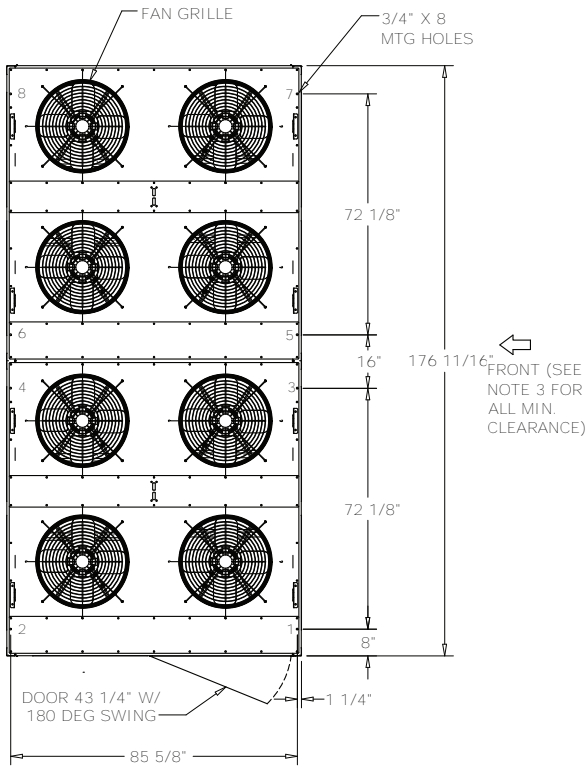

NOTES:

1. SEE CONNECTION DRAWING FOR CONNECTION LOCATION AND SIZES.
2. LOW AMBIENT DAMPER ONLY COMES WITH SELECTED UNIT.
3. FRONT AND BACK OF UNIT CLEARANCE 96". LEFT AND RIGHT SIDE OF UNIT CLEARANCE 48".

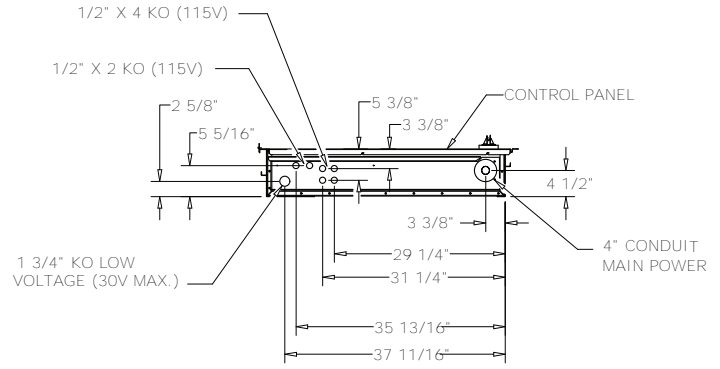

DETAIL A
DIMENSIONAL DETAIL

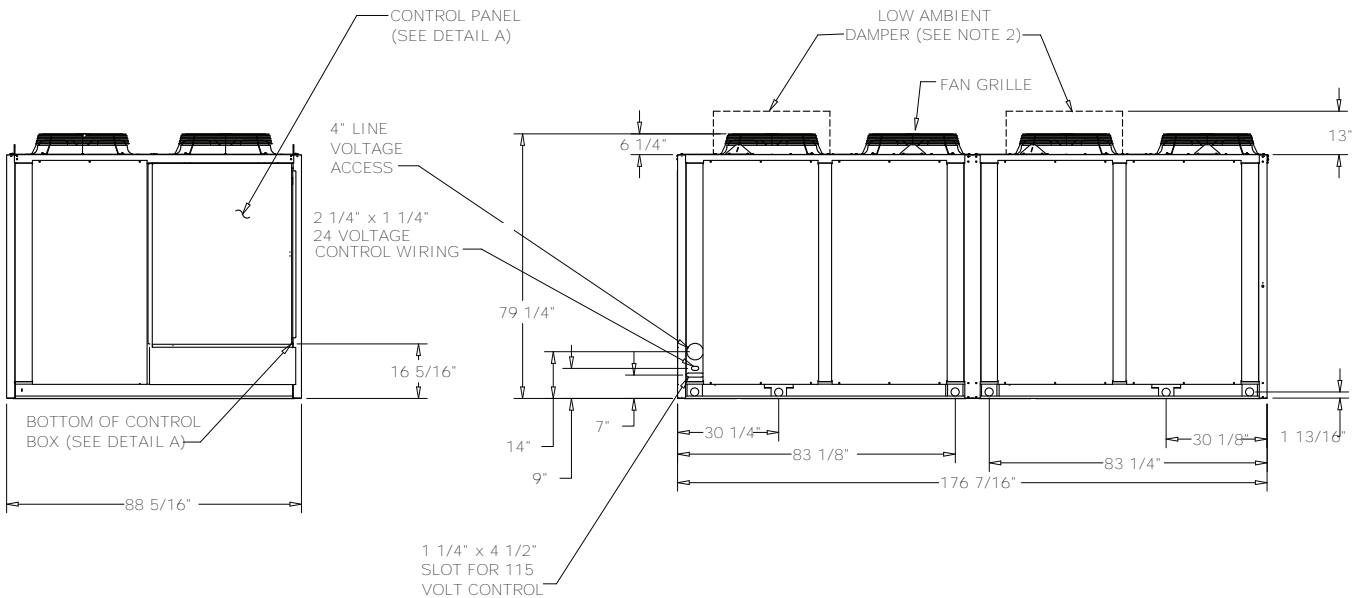
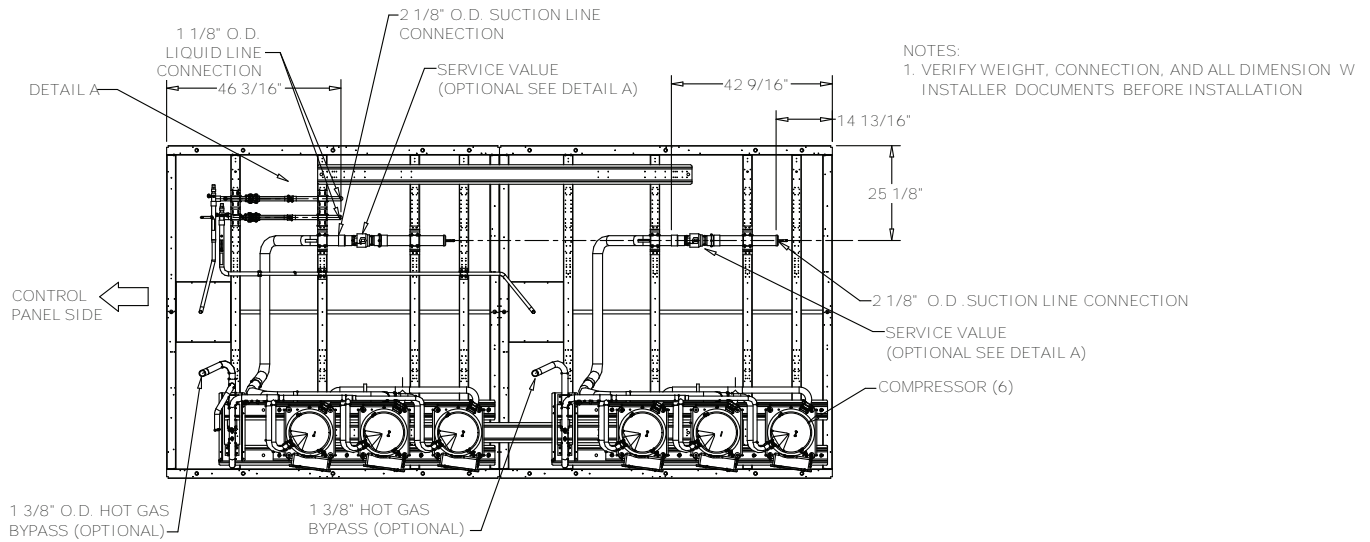
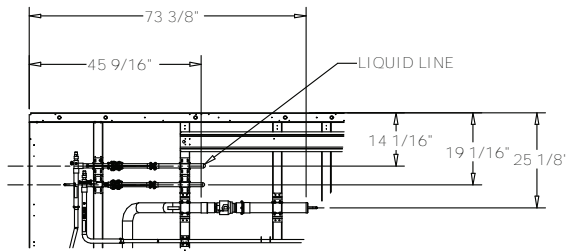

Figure 16. Air-cooled condensing unit connections — 80 ton



PLAN VIEW OF UNIT
 CONNECTION DRAWING



DETAIL A
 DETAIL DRAWING

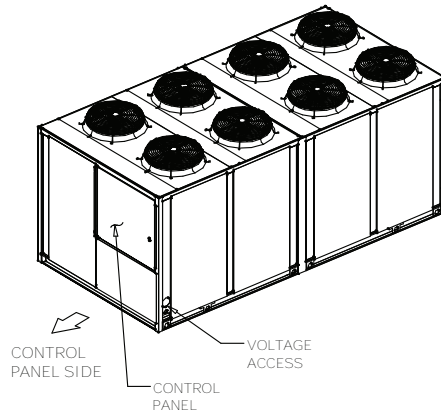

ORIENTATION VIEW OF UNIT
 ISOMETRIC DRAWING

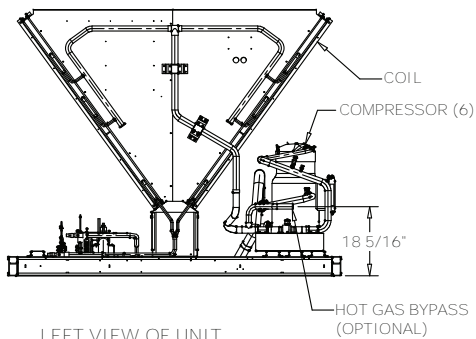

LEFT VIEW OF UNIT
 CONNECTION DRAWING

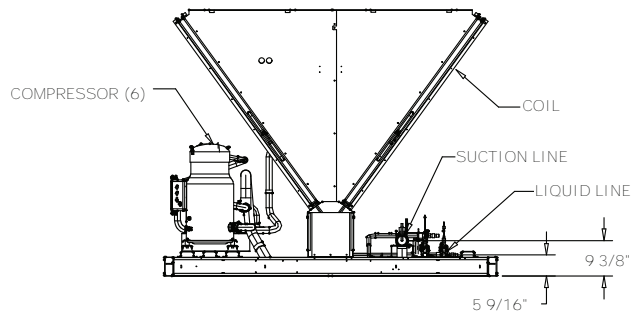

CONTROL PANEL SIDE VIEW OF UNIT
 CONNECTION DRAWING

80 TON UNIT
 DIMENSIONAL CONNECTION DRAWING

Dimensions and Weights

Figure 17. Air-cooled condensing unit — 100 and 120 tons

NOTES:

1. SEE CONNECTION DRAWING FOR CONNECTION LOCATION AND SIZES.
2. LOW AMBIENT DAMPER ONLY COMES WITH SELECTED UNIT .
3. FRONT AND BACK OF UNIT CLEARANCE 96" . LEFT AND RIGHT SIDE OF UNIT CLEARANCE 48" .

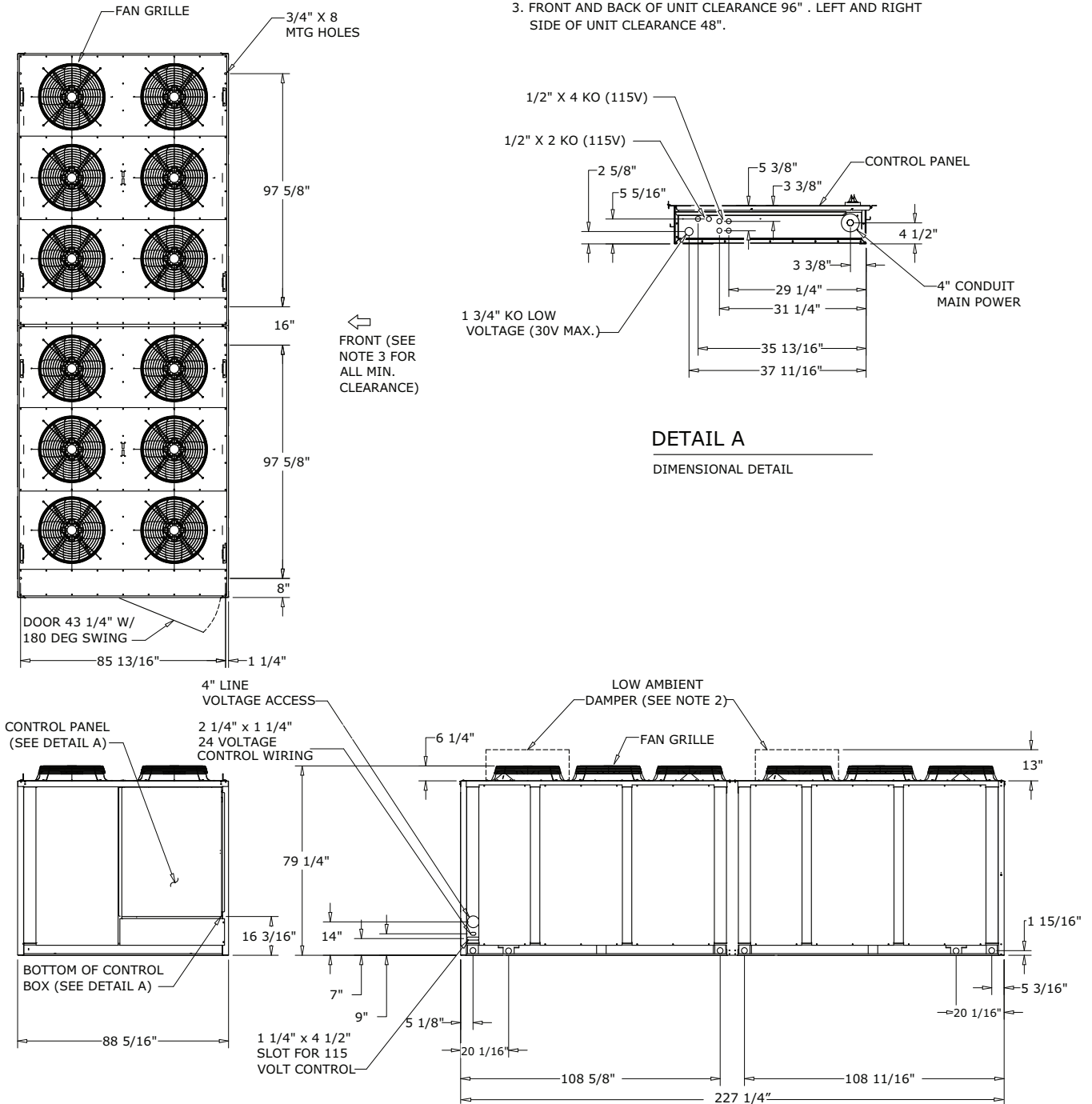
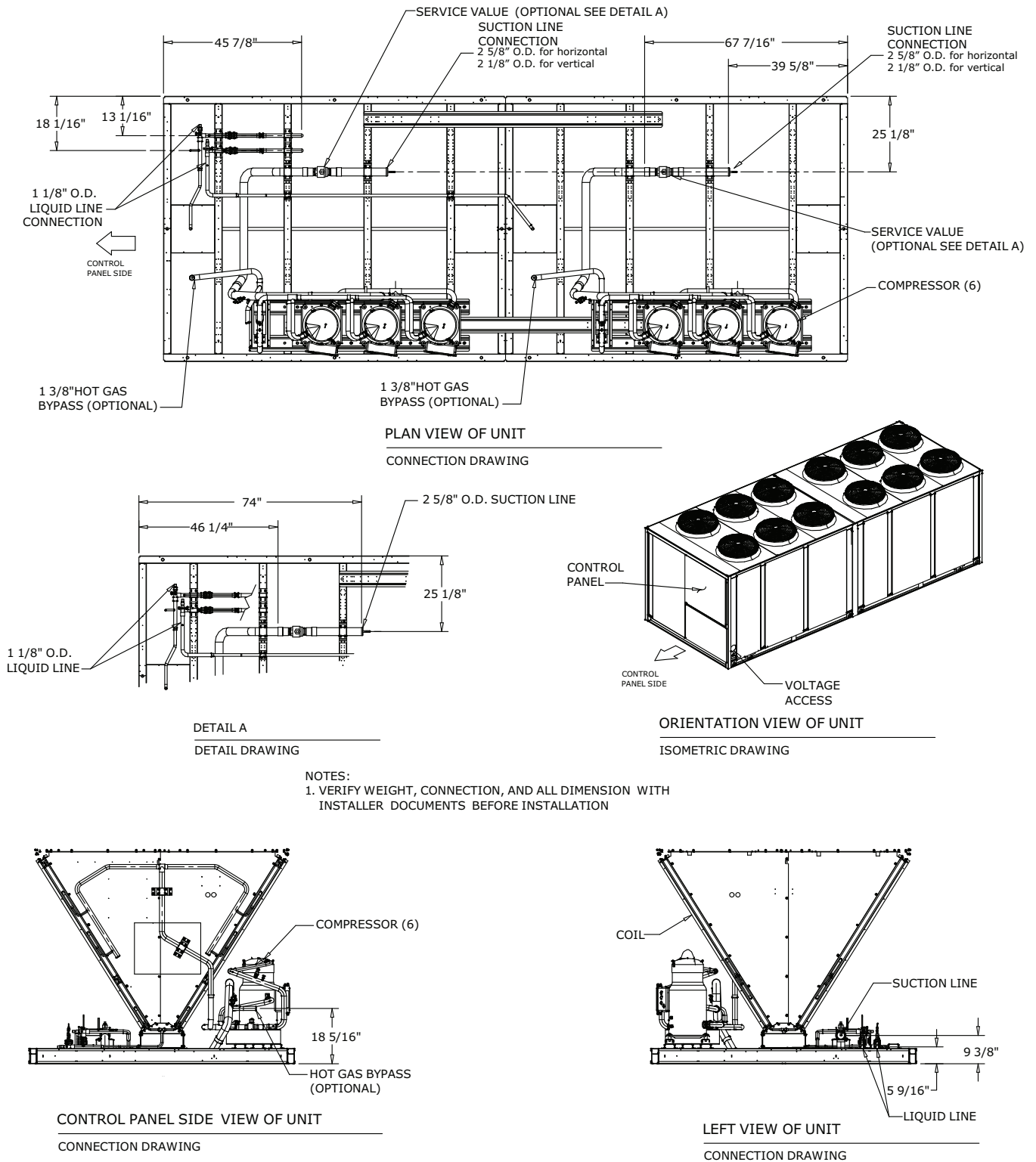

Figure 18. Air-cooled condensing unit connections — 100 and 120 tons



100 - 120 TON UNIT
DIMENSIONAL CONNECTION DRAWING

Dimensions and Weights

Figure 19. Evaporator chiller – 20 ton

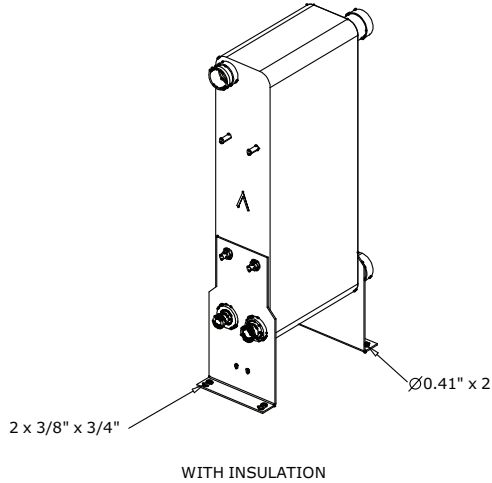

NOTES:

1. THIS HEAT EXCHANGER IS INTENDED FOR INDOOR INSTALLATION ONLY
2. HEAT EXCHANGER MOUNTING LEGS ARE INSTALLED AT JOB SITE WITH SUPPLIED FASTENERS
3. INSULATION SHOULD BE INSTALLED AFTER INSTALLING LEGS & REFRIGERANT TUBING, OR MUST BE ADEQUATELY SHIELDED AGAINST HEAT WHEN BRAZING REFRIGERANT LINES
4. INSTALL INSULATION SIDE PIECES FIRST THEN WRAPPER (MAY REQUIRE TRIMMING)
5. USE VINYL TAPE (FIELD SUPPLIED) TO SEAL INSULATION AFTER INSTALLATION
6. WATER CONNECTIONS ARE GROOVED (VICTAULIC)
7. REFRIGERANT CONNECTIONS ARE STAINLESS STEEL AND REQUIRE SPECIAL BRAZE MATERIALS. SEE IOM BRAZE PROCEDURE.
8. 1/2" X 14 NPT F4 CONNECTION SUPPLIED ON EXT 04 THRU 06 AND 08 10 ONLY BRAZED PLATE HEAT EXCHANGER REMOTE CHILLER EVAPORATOR OPTION

OPTION INCLUDES:

- 1 - BRAZED PLATE HEAT EXCHANGER - SHIPS SEPARATE FROM RAUJ CONDENSING UNIT
- 1 - INSTALLATION KIT, TO INCLUDE:
 - 2 - MOUNTING BRACKETS
 - 1 - INSULATION KIT
 - 1 - MOUNTING BRACKET & INSULATION KIT INSTALLATION INSTRUCTIONS
 - 1 - WATER CONNECTION KIT WITH PIPING STUBS, Y CONNECTOR, STRAINER, VICTAULIC CONNECTIONS WITH GASKETS, WATER FLOW SWITCH
 - 1 - WATER CONNECTION KIT INSTALLATION INSTRUCTIONS

INSTALLATION ADDITIONALLY REQUIRES:

- RAUJ REMOTE EVP CONTROL PANEL WITH LEAVING WATER TEMPERATURE SENSOR, FREEZE-STAT, AND INSTALLATION INSTRUCTIONS - ALL INCLUDED WITH REMOTE EVP CONTROL PANEL
- 4 - FIELD PROVIDED 7/16" BOLTS FOR SECURING BRAZED PLATE HEAT EXCHANGER TO PERMANENT MOUNTING SURFACE
- 2 - FIELD PROVIDED 1/2" - 14 NPTE PLUGS, STAINLESS STEEL OR PVC
- FIELD PROVIDED TEFLON TAPE FOR SEALING 1/2" PIPE PLUGS
- FIELD PROVIDED WATER STRAINER PLUG OR BLOW DOWN VALVE
- FIELD PROVIDED TEE FOR INSTALLING WATER FLOW SWITCH
- FIELD PROVIDED 2" VINYL TAPE FOR SEALING INSULATION SEAMS

SEE IOM FOR INSTALLATION DETAIL

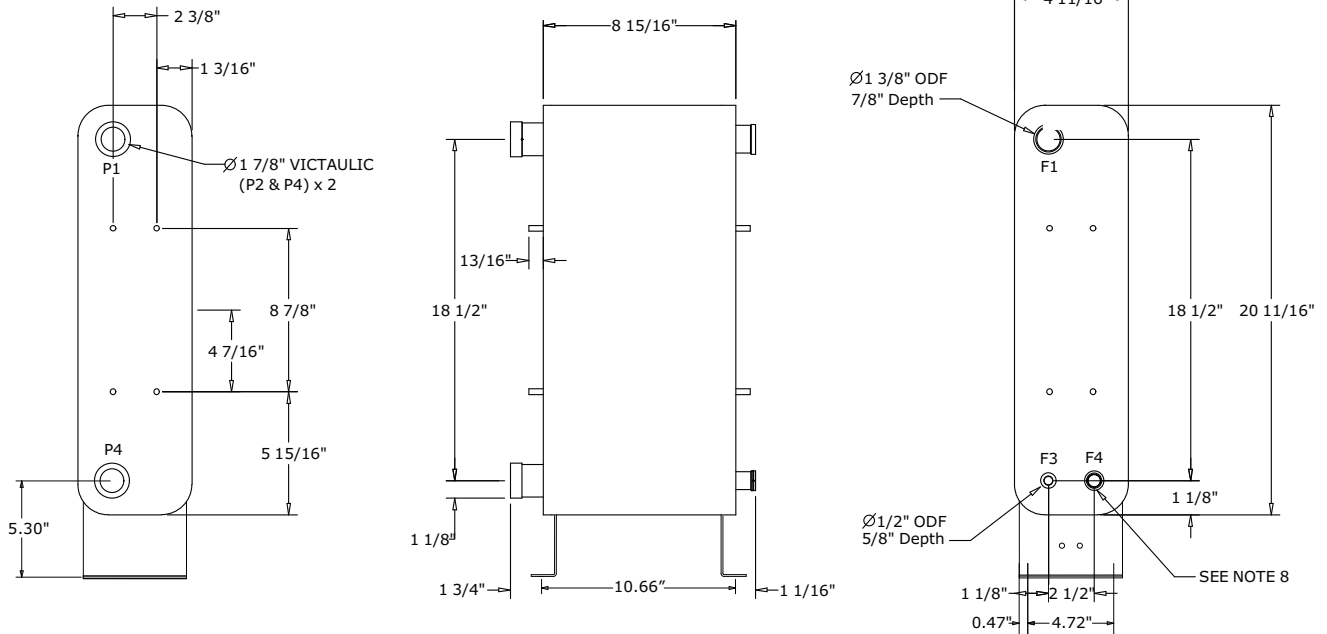

20 TON BRAZED PLATE HEAT EXCHANGER

ACCESSORY DRAWING

Figure 20. Evaporator chiller – 25 ton

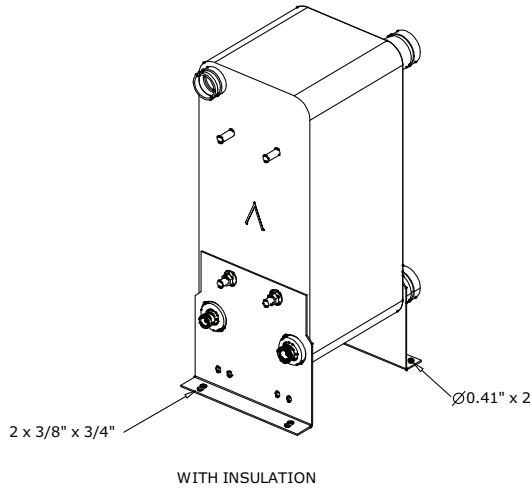

NOTES:

1. THIS HEAT EXCHANGER IS INTENDED FOR INDOOR INSTALLATION ONLY
2. HEAT EXCHANGER MOUNTING LEGS ARE INSTALLED AT JOB SITE WITH SUPPLIED FASTENERS
3. INSULATION SHOULD BE INSTALLED AFTER INSTALLING LEGS & REFRIGERANT TUBING, OR MUST BE ADEQUATELY SHIELDED AGAINST HEAT WHEN BRAZING REFRIGERANT LINES
4. INSTALL INSULATION SIDE PIECES FIRST THEN WRAPPER (MAY REQUIRE TRIMMING)
5. USE VINYL TAPE (FIELD SUPPLIED) TO SEAL INSULATION AFTER INSTALLATION
6. WATER CONNECTIONS ARE GROOVED (VICTAULIC)
7. REFRIGERANT CONNECTIONS ARE STAINLESS STEEL AND REQUIRE SPECIAL BRAZE MATERIALS. SEE IOM BRAZE PROCEDURE.
8. 1/2" - 14 NPT F4 CONNECTION SUPPLIED ON EXT'S 05 THRU 08 AND 13 THRU 16 ONLY.

BRAZED PLATE HEAT EXCHANGER REMOTE CHILLER EVAPORATOR OPTION

OPTION INCLUDES:

- 1 - BRAZED PLATE HEAT EXCHANGER - SHIPS SEPARATE FROM RAUJ CONDENSING UNIT

1 - INSTALLATION KIT, TO INCLUDE:

- 2 - MOUNTING BRACKETS
- 1 - INSULATION KIT
- 1 - MOUNTING BRACKET & INSULATION KIT INSTALLATION INSTRUCTIONS
- 1 - WATER CONNECTION KIT WITH PIPING STUBS, Y CONNECTOR, STRAINER, VICTAULIC CONNECTIONS WITH GASKETS, WATER FLOW SWITCH
- 1 - WATER CONNECTION KIT INSTALLATION INSTRUCTIONS

INSTALLATION ADDITIONALLY REQUIRES:

- RAUJ REMOTE EVP CONTROL PANEL WITH LEAVING WATER TEMPERATURE SENSOR, FREEZE-STAT, AND INSTALLATION INSTRUCTIONS - ALL INCLUDED WITH REMOTE EVP CONTROL PANEL

- 4 - FIELD PROVIDED 7/16" BOLTS FOR SECURING BRAZED PLATE HEAT EXCHANGER TO PERMANENT MOUNTING SURFACE

- 2 - FIELD PROVIDED 1/2" - 14 NPT PLUGS, STAINLESS STEEL OR PVC

- FIELD PROVIDED TEFLON TAPE FOR SEALING 1/2" PIPE PLUGS

- FIELD PROVIDED WATER STRAINER PLUG OR BLOW DOWN VALVE

- FIELD PROVIDED TEE FOR INSTALLING WATER FLOW SWITCH

- FIELD PROVIDED 2" VINYL TAPE FOR SEALING INSULATION SEAMS

SEE IOM FOR INSTALLATION DETAIL

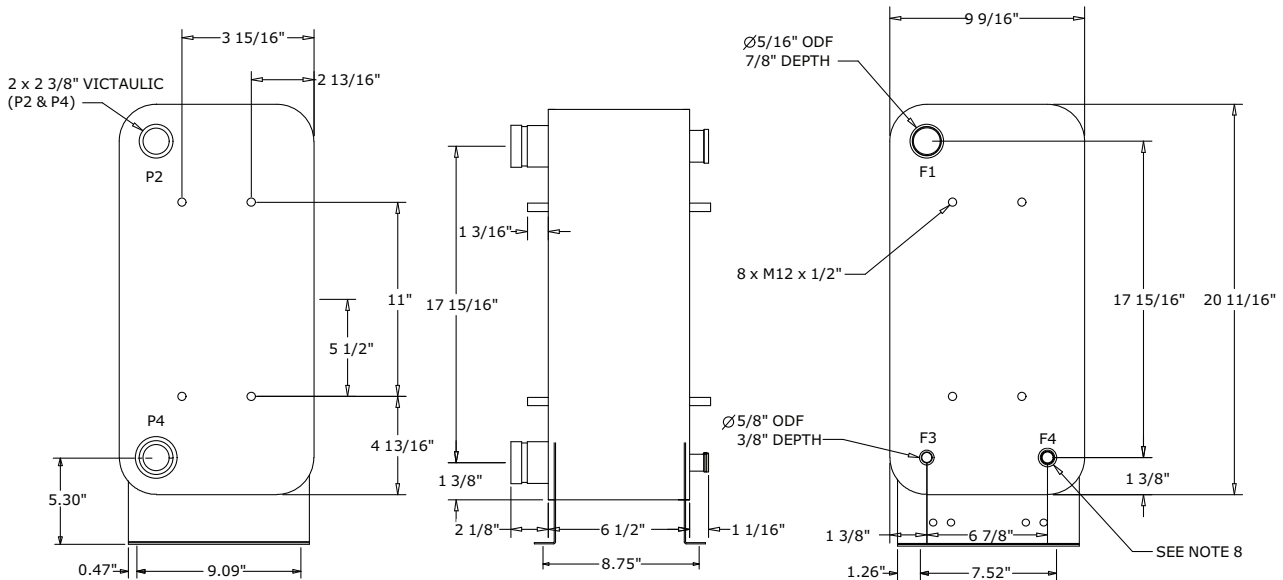

25 TON BRAZED PLATE HEAT EXCHANGER

ACCESSORY DRAWING



Dimensions and Weights

Figure 21. Evaporator chiller — 30 ton

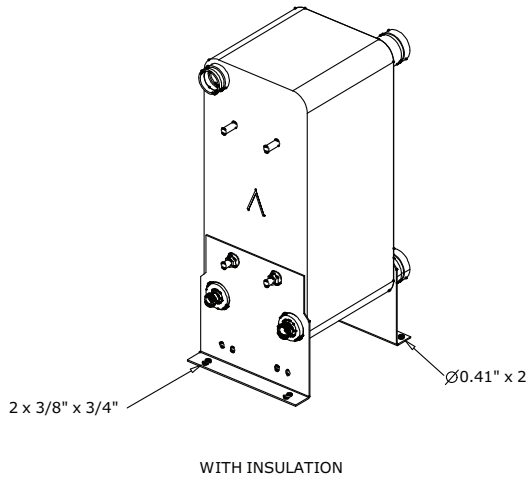

NOTES:

1. THIS HEAT EXCHANGER IS INTENDED FOR INDOOR INSTALLATION ONLY
2. HEAT EXCHANGER MOUNTING LEGS ARE INSTALLED AT JOB SITE WITH SUPPLIED FASTENERS
3. INSULATION SHOULD BE INSTALLED AFTER INSTALLING LEGS & REFRIGERANT TUBING, OR MUST BE ADEQUATELY SHIELDED AGAINST HEAT WHEN BRAZING REFRIGERANT LINES
4. INSTALL INSULATION SIDE PIECES FIRST THEN WRAPPER (MAY REQUIRE TRIMMING)
5. USE VINYL TAPE (FIELD SUPPLIED) TO SEAL INSULATION AFTER INSTALLATION
6. WATER CONNECTIONS ARE GROOVED (VICTAULIC)
7. REFRIGERANT CONNECTIONS ARE STAINLESS STEEL AND REQUIRE SPECIAL BRAZE MATERIALS. SEE IOM BRAZE PROCEDURE.
8. 1/2" - 14 NPT F4 CONNECTION SUPPLIED ON EXT'S 05 THRU 08 AND 13 THRU 16 ONLY.

BRAZED PLATE HEAT EXCHANGER REMOTE CHILLER EVAPORATOR OPTION

OPTION INCLUDES:

- 1 - BRAZED PLATE HEAT EXCHANGER - SHIPS SEPARATE FROM RAUJ CONDENSING UNIT
- 1 - INSTALLATION KIT, TO INCLUDE:
 - 2 - MOUNTING BRACKETS
 - 1 - INSULATION KIT
 - 1 - MOUNTING BRACKET & INSULATION KIT INSTALLATION INSTRUCTIONS
- 1 - WATER CONNECTION KIT WITH PIPING STUBS, Y CONNECTOR, STRAINER, VICTAULIC CONNECTIONS WITH GASKETS, WATER FLOW SWITCH
- 1 - WATER CONNECTION KIT INSTALLATION INSTRUCTIONS

INSTALLATION ADDITIONALLY REQUIRES:

- RAUJ REMOTE EVP CONTROL PANEL WITH LEAVING WATER TEMPERATURE SENSOR, FREEZE-STAT, AND INSTALLATION INSTRUCTIONS - ALL INCLUDED WITH REMOTE EVP CONTROL PANEL
- 4 - FIELD PROVIDED 7/16" BOLTS FOR SECURING BRAZED PLATE HEAT EXCHANGER TO PERMANENT MOUNTING SURFACE
- 2 - FIELD PROVIDED 1/2" - 14 NPTE PLUGS, STAINLESS STEEL OR PVC
- FIELD PROVIDED TEFLON TAPE FOR SEALING 1/2" PIPE PLUGS
- FIELD PROVIDED WATER STRAINER PLUG OR BLOW DOWN VALVE
- FIELD PROVIDED TEE FOR INSTALLING WATER FLOW SWITCH
- FIELD PROVIDED 2" VINYL TAPE FOR SEALING INSULATION SEAMS

SEE IOM FOR INSTALLATION DETAIL

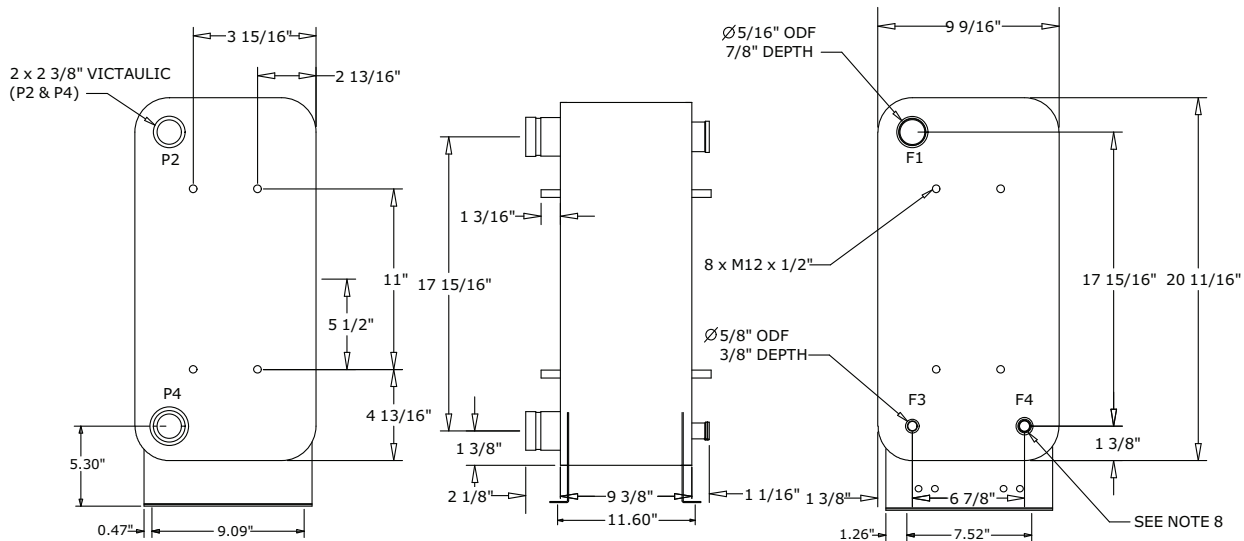

30 TON BRAZED PLATE HEAT EXCHANGER

ACCESSORY DRAWING

Figure 22. Evaporator chiller — 40 ton

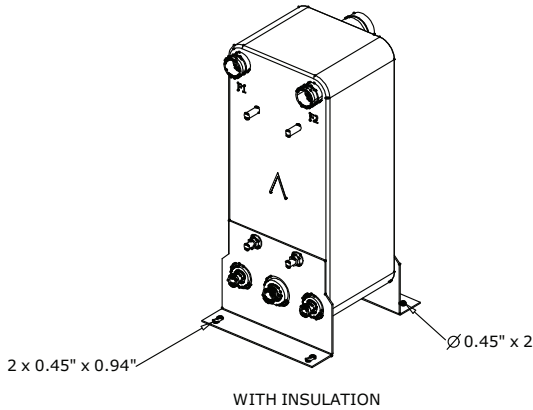

NOTES:

1. THIS HEAT EXCHANGER IS INTENDED FOR INDOOR INSTALLATION ONLY
2. HEAT EXCHANGER MOUNTING LEGS ARE INSTALLED AT JOB SITE WITH SUPPLIED FASTENERS
3. INSULATION SHOULD BE INSTALLED AFTER INSTALLING LEGS & REFRIGERANT TUBING, OR MUST BE ADEQUATELY SHIELDED AGAINST HEAT WHEN BRAZING REFRIGERANT LINES
4. INSTALL INSULATION SIDE PIECES FIRST THEN WRAPPER (MAY REQUIRE TRIMMING)
5. USE VINYL TAPE (FIELD SUPPLIED) TO SEAL INSULATION AFTER INSTALLATION
6. WATER CONNECTIONS ARE GROOVED (VICTAULIC)
7. REFRIGERANT CONNECTIONS ARE STAINLESS STEEL AND REQUIRE SPECIAL BRAZE MATERIALS. SEE IOM BRAZE PROCEDURE.
8. 1/2" NPT F5 CONNECTION SUPPLIED ON EXT'S 04 THRU 06 ONLY
BRAZED PLATE HEAT EXCHANGER REMOTE CHILLER EVAPORATOR OPTION

OPTION INCLUDES:

- 1 - BRAZED PLATE HEAT EXCHANGER - SHIPS SEPARATE FROM RAUJ CONDENSING UNIT
- 1 - INSTALLATION KIT, TO INCLUDE:
 - 2 - MOUNTING BRACKETS
 - 1 - INSULATION KIT
 - 1 - MOUNTING BRACKET & INSULATION KIT INSTALLATION INSTRUCTIONS
- 1 - WATER CONNECTION KIT WITH PIPING STUBS, Y CONNECTOR, STRAINER, VICTAULIC CONNECTIONS WITH GASKETS, WATER FLOW SWITCH
- 1 - WATER CONNECTION KIT INSTALLATION INSTRUCTIONS

INSTALLATION ADDITIONALLY REQUIRES:

- RAUJ REMOTE EVP CONTROL PANEL WITH LEAVING WATER TEMPERATURE SENSOR, FREEZE-STAT, AND INSTALLATION INSTRUCTIONS - ALL INCLUDED WITH REMOTE EVP CONTROL PANEL
- 4 - FIELD PROVIDED 7/16" BOLTS FOR SECURING BRAZED PLATE HEAT EXCHANGER TO PERMANENT MOUNTING SURFACE
- 2 - FIELD PROVIDED 1/2" - 14 NPTE PLUGS, STAINLESS STEEL OR PVC
- FIELD PROVIDED TEFLON TAPE FOR SEALING 1/2" PIPE PLUGS
- FIELD PROVIDED WATER STRAINER PLUG OR BLOW DOWN VALVE
- FIELD PROVIDED TEE FOR INSTALLING WATER FLOW SWITCH
- FIELD PROVIDED 2" VINYL TAPE FOR SEALING INSULATION SEAMS

SEE IOM FOR INSTALLATION DETAIL

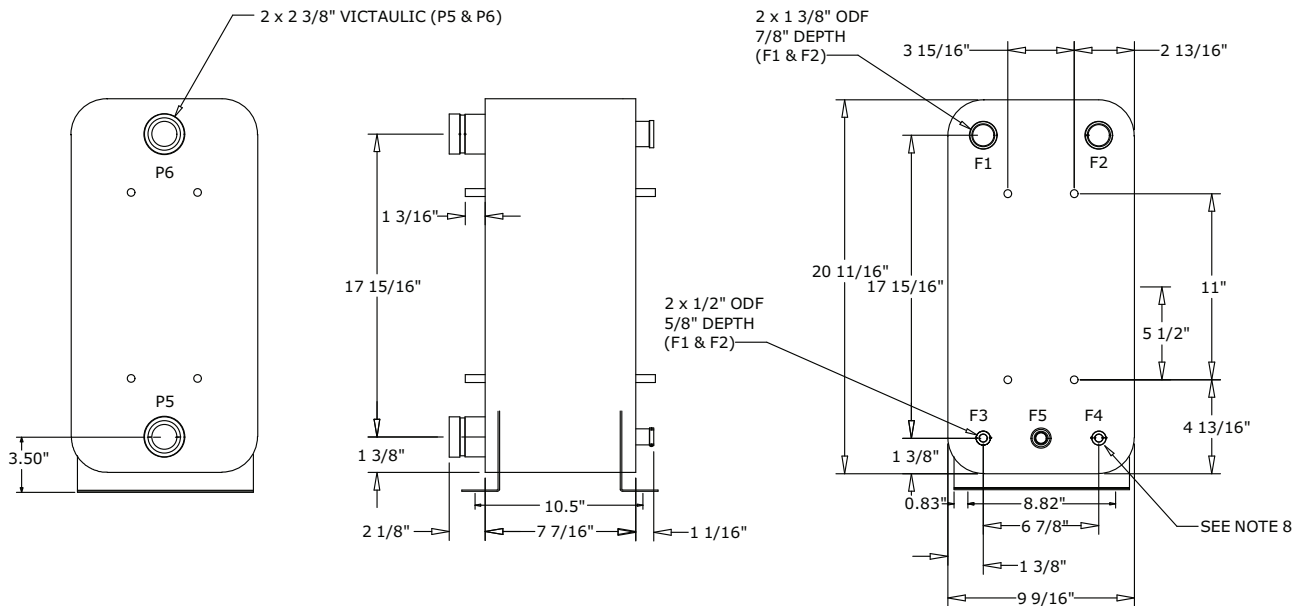

40 TON BRAZED PLATE HEAT EXCHANGER

ACCESSORY DRAWING



Dimensions and Weights

Figure 23. Evaporator chiller – 50 ton

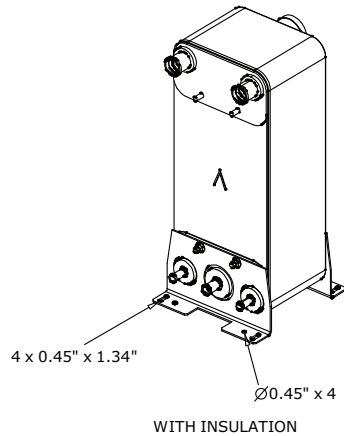

NOTES:

1. THIS HEAT EXCHANGER IS INTENDED FOR INDOOR INSTALLATION ONLY
2. HEAT EXCHANGER MOUNTING LEGS ARE INSTALLED AT JOB SITE WITH SUPPLIED FASTENERS
3. INSULATION SHOULD BE INSTALLED AFTER INSTALLING LEGS & REFRIGERANT TUBING, OR MUST BE ADEQUATELY SHIELDED AGAINST HEAT WHEN BRAZING REFRIGERANT LINES
4. INSTALL INSULATION SIDE PIECES FIRST THEN WRAPPER (MAY REQUIRE TRIMMING)
5. USE VINYL TAPE (FIELD SUPPLIED) TO SEAL INSULATION AFTER INSTALLATION
6. WATER CONNECTIONS ARE GROOVED (VICTAULIC)
7. REFRIGERANT CONNECTIONS ARE STAINLESS STEEL AND REQUIRE SPECIAL BRAZE MATERIALS. SEE IOM BRAZE PROCEDURE.
8. 1/2" - 14 NPT F5 CONNECTION SUPPLIED ON EXT'S 13 THRU 24 AND 37 THRU 48 ONLY.

BRAZED PLATE HEAT EXCHANGER REMOTE CHILLER EVAPORATOR OPTION

OPTION INCLUDES:

- 1 - BRAZED PLATE HEAT EXCHANGER - SHIPS SEPARATE FROM RAUJ CONDENSING UNIT
- 1 - INSTALLATION KIT, TO INCLUDE:
 - 2 - MOUNTING BRACKETS
 - 1 - INSULATION KIT
 - 1 - MOUNTING BRACKET & INSULATION KIT INSTALLATION INSTRUCTIONS
- 1 - WATER CONNECTION KIT WITH PIPING STUBS, Y CONNECTOR, STRAINER, VICTAULIC CONNECTIONS WITH GASKETS, WATER FLOW SWITCH
- 1 - WATER CONNECTION KIT INSTALLATION INSTRUCTIONS

INSTALLATION ADDITIONALLY REQUIRES:

- RAUJ REMOTE EVP CONTROL PANEL WITH LEAVING WATER TEMPERATURE SENSOR, FREEZE-STAT, AND INSTALLATION INSTRUCTIONS - ALL INCLUDED WITH REMOTE EVP CONTROL PANEL
- 4 - FIELD PROVIDED 7/16" BOLTS FOR SECURING BRAZED PLATE HEAT EXCHANGER TO PERMANENT MOUNTING SURFACE
- 2 - FIELD PROVIDED 1/2" - 14 NPT PLUGS, STAINLESS STEEL OR PVC
- FIELD PROVIDED TEFLON TAPE FOR SEALING 1/2" PIPE PLUGS
- FIELD PROVIDED WATER STRAINER PLUG OR BLOW DOWN VALVE
- FIELD PROVIDED TEE FOR INSTALLING WATER FLOW SWITCH
- FIELD PROVIDED 2" VINYL TAPE FOR SEALING INSULATION SEAMS

SEE IOM FOR INSTALLATION DETAIL

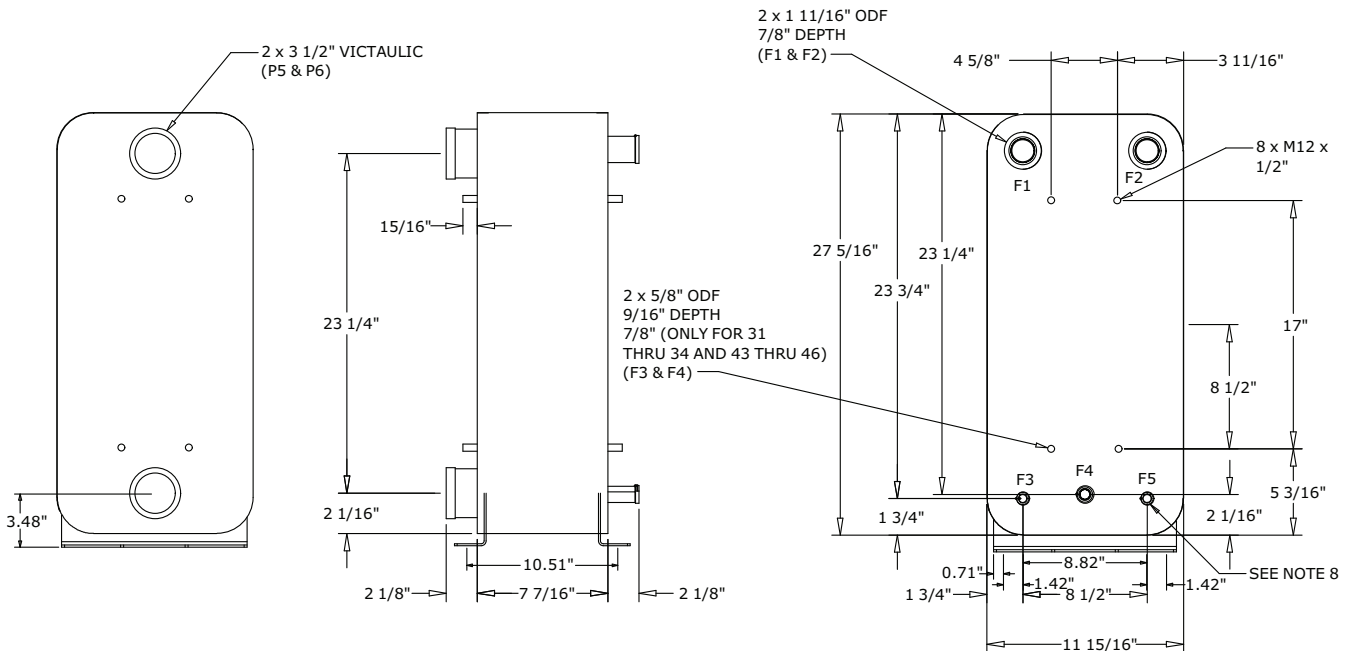

50 TON BRAZED PLATE HEAT EXCHANGER

ACCESSORY DRAWING

Figure 24. Evaporator chiller – 60 ton

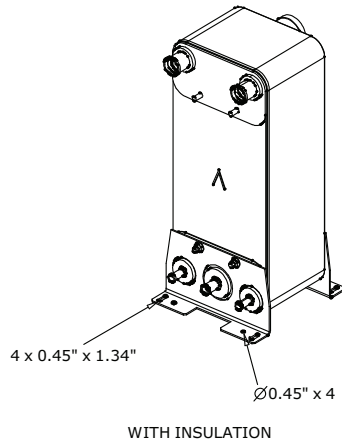

NOTES:

1. THIS HEAT EXCHANGER IS INTENDED FOR INDOOR INSTALLATION ONLY
2. HEAT EXCHANGER MOUNTING LEGS ARE INSTALLED AT JOB SITE WITH SUPPLIED FASTENERS
3. INSULATION SHOULD BE INSTALLED AFTER INSTALLING LEGS & REFRIGERANT TUBING, OR MUST BE ADEQUATELY SHIELDED AGAINST HEAT WHEN BRAZING REFRIGERANT LINES
4. INSTALL INSULATION SIDE PIECES FIRST THEN WRAPPER (MAY REQUIRE TRIMMING)
5. USE VINYL TAPE (FIELD SUPPLIED) TO SEAL INSULATION AFTER INSTALLATION
6. WATER CONNECTIONS ARE GROOVED (VICTAULIC)
7. REFRIGERANT CONNECTIONS ARE STAINLESS STEEL AND REQUIRE SPECIAL BRAZE MATERIALS. SEE IOM BRAZE PROCEDURE.
8. 1/2" - 14 NPT F5 CONNECTION SUPPLIED ON EXT'S 13 THRU 24 AND 37 THRU 48 ONLY.

BRAZED PLATE HEAT EXCHANGER REMOTE CHILLER EVAPORATOR OPTION

OPTION INCLUDES:

- 1 - BRAZED PLATE HEAT EXCHANGER - SHIPS SEPARATE FROM RAUJ CONDENSING UNIT
- 1 - INSTALLATION KIT, TO INCLUDE:
 - 2 - MOUNTING BRACKETS
 - 1 - INSULATION KIT
 - 1 - MOUNTING BRACKET & INSULATION KIT INSTALLATION INSTRUCTIONS
- 1 - WATER CONNECTION KIT WITH PIPING STUBS, Y CONNECTOR, STRAINER, VICTAULIC CONNECTIONS WITH GASKETS, WATER FLOW SWITCH
- 1 - WATER CONNECTION KIT INSTALLATION INSTRUCTIONS

INSTALLATION ADDITIONALLY REQUIRES:

- RAUJ REMOTE EVP CONTROL PANEL WITH LEAVING WATER TEMPERATURE SENSOR, FREEZE-STAT, AND INSTALLATION INSTRUCTIONS - ALL INCLUDED WITH REMOTE EVP CONTROL PANEL
- 4 - FIELD PROVIDED 7/16" BOLTS FOR SECURING BRAZED PLATE HEAT EXCHANGER TO PERMANENT MOUNTING SURFACE
- 2 - FIELD PROVIDED 1/2" - 14 NPT PLUGS, STAINLESS STEEL OR PVC
- FIELD PROVIDED TEFLON TAPE FOR SEALING 1/2" PIPE PLUGS
- FIELD PROVIDED WATER STRAINER PLUG OR BLOW DOWN VALVE
- FIELD PROVIDED TEE FOR INSTALLING WATER FLOW SWITCH
- FIELD PROVIDED 2" VINYL TAPE FOR SEALING INSULATION SEAMS

SEE IOM FOR INSTALLATION DETAIL

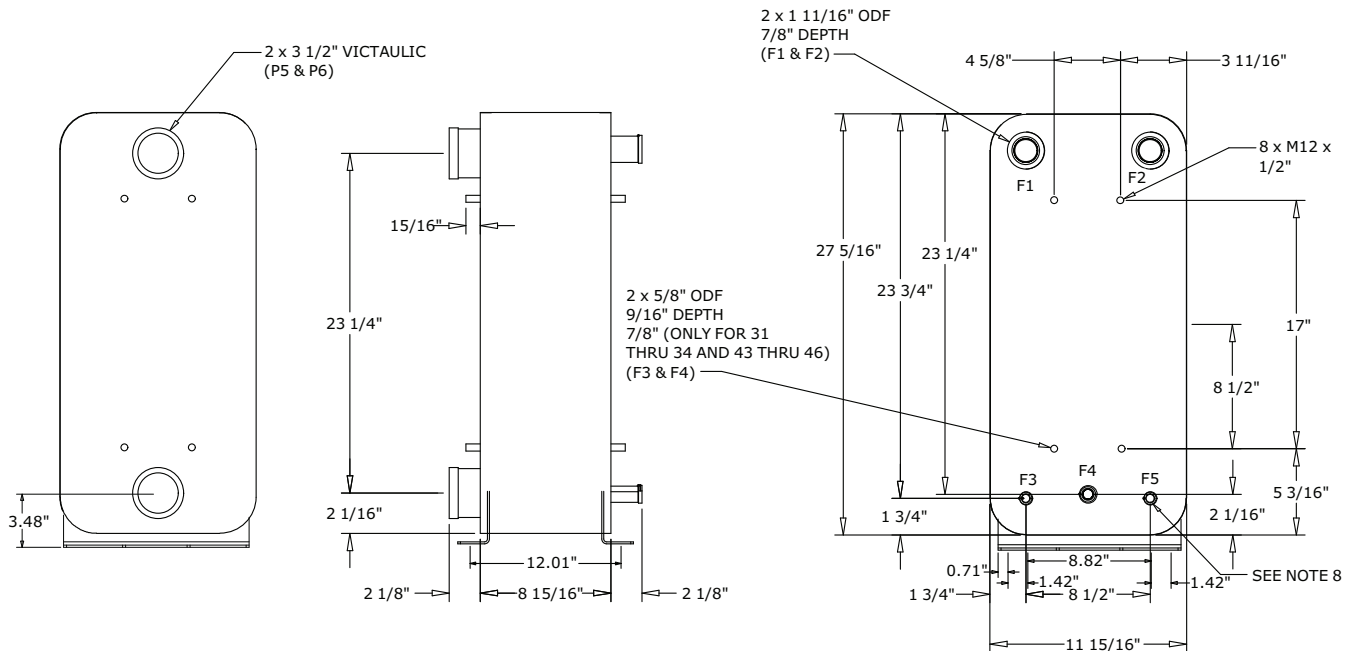

60 TON BRAZED PLATE HEAT EXCHANGER

ACCESSORY DRAWING



Dimensions and Weights

Figure 25. Evaporator chiller — 80 ton

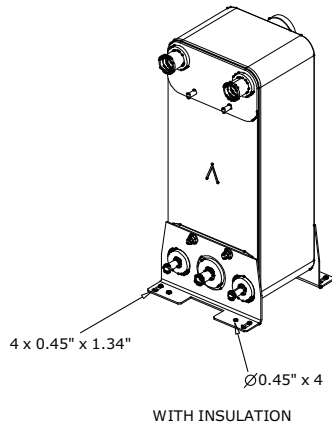

NOTES:

1. THIS HEAT EXCHANGER IS INTENDED FOR INDOOR INSTALLATION ONLY
2. HEAT EXCHANGER MOUNTING LEGS ARE INSTALLED AT JOB SITE WITH SUPPLIED FASTENERS
3. INSULATION SHOULD BE INSTALLED AFTER INSTALLING LEGS & REFRIGERANT TUBING, OR MUST BE ADEQUATELY SHIELDED AGAINST HEAT WHEN BRAZING REFRIGERANT LINES
4. INSTALL INSULATION SIDE PIECES FIRST THEN WRAPPER (MAY REQUIRE TRIMMING)
5. USE VINYL TAPE (FIELD SUPPLIED) TO SEAL INSULATION AFTER INSTALLATION
6. WATER CONNECTIONS ARE GROOVED (VICTAULIC)
7. REFRIGERANT CONNECTIONS ARE STAINLESS STEEL AND REQUIRE SPECIAL BRAZE MATERIALS. SEE IOM BRAZE PROCEDURE.
8. 1/2" - 14 NPT F5 CONNECTION SUPPLIED ON EXT'S 13 THRU 24 AND 37 THRU 48 ONLY.

BRAZED PLATE HEAT EXCHANGER REMOTE CHILLER EVAPORATOR OPTION

OPTION INCLUDES:

- 1 - BRAZED PLATE HEAT EXCHANGER - SHIPS SEPARATE FROM RAUJ CONDENSING UNIT
- 1 - INSTALLATION KIT, TO INCLUDE:
 - 2 - MOUNTING BRACKETS
 - 1 - INSULATION KIT
 - 1 - MOUNTING BRACKET & INSULATION KIT INSTALLATION INSTRUCTIONS
- 1 - WATER CONNECTION KIT WITH PIPING STUBS, Y CONNECTOR, STRAINER, VICTAULIC CONNECTIONS WITH GASKETS, WATER FLOW SWITCH
- 1 - WATER CONNECTION KIT INSTALLATION INSTRUCTIONS

INSTALLATION ADDITIONALLY REQUIRES:

- RAUJ REMOTE EVP CONTROL PANEL WITH LEAVING WATER TEMPERATURE SENSOR, FREEZE-STAT, AND INSTALLATION INSTRUCTIONS - ALL INCLUDED WITH REMOTE EVP CONTROL PANEL
- 4 - FIELD PROVIDED 7/16" BOLTS FOR SECURING BRAZED PLATE HEAT EXCHANGER TO PERMANENT MOUNTING SURFACE
- 2 - FIELD PROVIDED 1/2" - 14 NPT PLUGS, STAINLESS STEEL OR PVC
- FIELD PROVIDED TEFLON TAPE FOR SEALING 1/2" PIPE PLUGS
- FIELD PROVIDED WATER STRAINER PLUG OR BLOW DOWN VALVE
- FIELD PROVIDED TEE FOR INSTALLING WATER FLOW SWITCH
- FIELD PROVIDED 2" VINYL TAPE FOR SEALING INSULATION SEAMS

SEE IOM FOR INSTALLATION DETAIL

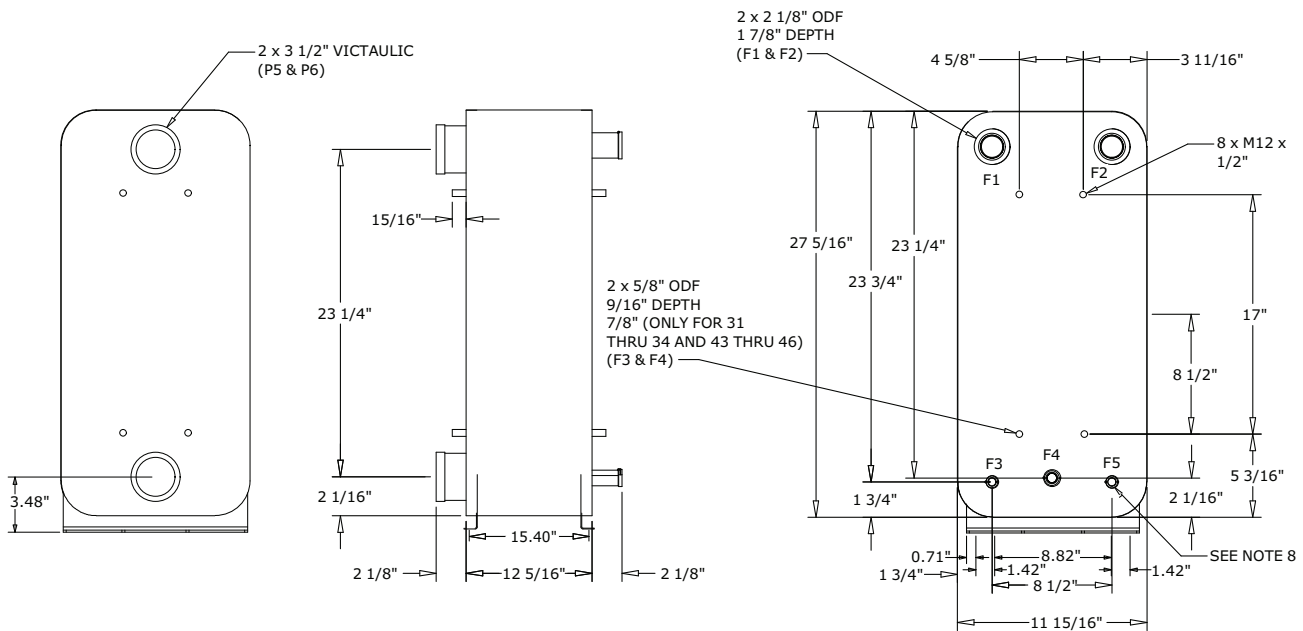

80 TON BRAZED PLATE HEAT EXCHANGER

ACCESSORY DRAWING

Figure 26. Evaporator chiller — 100 ton

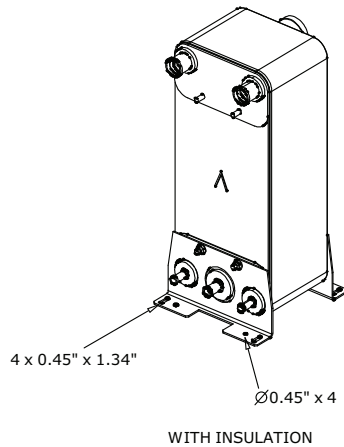

NOTES:

1. THIS HEAT EXCHANGER IS INTENDED FOR INDOOR INSTALLATION ONLY
2. HEAT EXCHANGER MOUNTING LEGS ARE INSTALLED AT JOB SITE WITH SUPPLIED FASTENERS
3. INSULATION SHOULD BE INSTALLED AFTER INSTALLING LEGS & REFRIGERANT TUBING, OR MUST BE ADEQUATELY SHIELDED AGAINST HEAT WHEN BRAZING REFRIGERANT LINES
4. INSTALL INSULATION SIDE PIECES FIRST THEN WRAPPER (MAY REQUIRE TRIMMING)
5. USE VINYL TAPE (FIELD SUPPLIED) TO SEAL INSULATION AFTER INSTALLATION
6. WATER CONNECTIONS ARE GROOVED (VICTAULIC)
7. REFRIGERANT CONNECTIONS ARE STAINLESS STEEL AND REQUIRE SPECIAL BRAZE MATERIALS. SEE IOM BRAZE PROCEDURE.
8. 1/2" - 14 NPT F5 CONNECTION SUPPLIED ON EXT'S 13 THRU 24 AND 37 THRU 48 ONLY.

BRAZED PLATE HEAT EXCHANGER REMOTE CHILLER EVAPORATOR OPTION

OPTION INCLUDES:

- 1 - BRAZED PLATE HEAT EXCHANGER - SHIPS SEPARATE FROM RAUJ CONDENSING UNIT
- 1 - INSTALLATION KIT, TO INCLUDE:
 - 2 - MOUNTING BRACKETS
 - 1 - INSULATION KIT
 - 1 - MOUNTING BRACKET & INSULATION KIT INSTALLATION INSTRUCTIONS
- 1 - WATER CONNECTION KIT WITH PIPING STUBS, Y CONNECTOR, STRAINER, VICTAULIC CONNECTIONS WITH GASKETS, WATER FLOW SWITCH
- 1 - WATER CONNECTION KIT INSTALLATION INSTRUCTIONS

INSTALLATION ADDITIONALLY REQUIRES:

- RAUJ REMOTE EVP CONTROL PANEL WITH LEAVING WATER TEMPERATURE SENSOR, FREEZE-STAT, AND INSTALLATION INSTRUCTIONS - ALL INCLUDED WITH REMOTE EVP CONTROL PANEL
- 4 - FIELD PROVIDED 7/16" BOLTS FOR SECURING BRAZED PLATE HEAT EXCHANGER TO PERMANENT MOUNTING SURFACE
- 2 - FIELD PROVIDED 1/2" - 14 NPT PLUGS, STAINLESS STEEL OR PVC
- FIELD PROVIDED TEFLON TAPE FOR SEALING 1/2" PIPE PLUGS
- FIELD PROVIDED WATER STRAINER PLUG OR BLOW DOWN VALVE
- FIELD PROVIDED TEE FOR INSTALLING WATER FLOW SWITCH
- FIELD PROVIDED 2" VINYL TAPE FOR SEALING INSULATION SEAMS

SEE IOM FOR INSTALLATION DETAIL

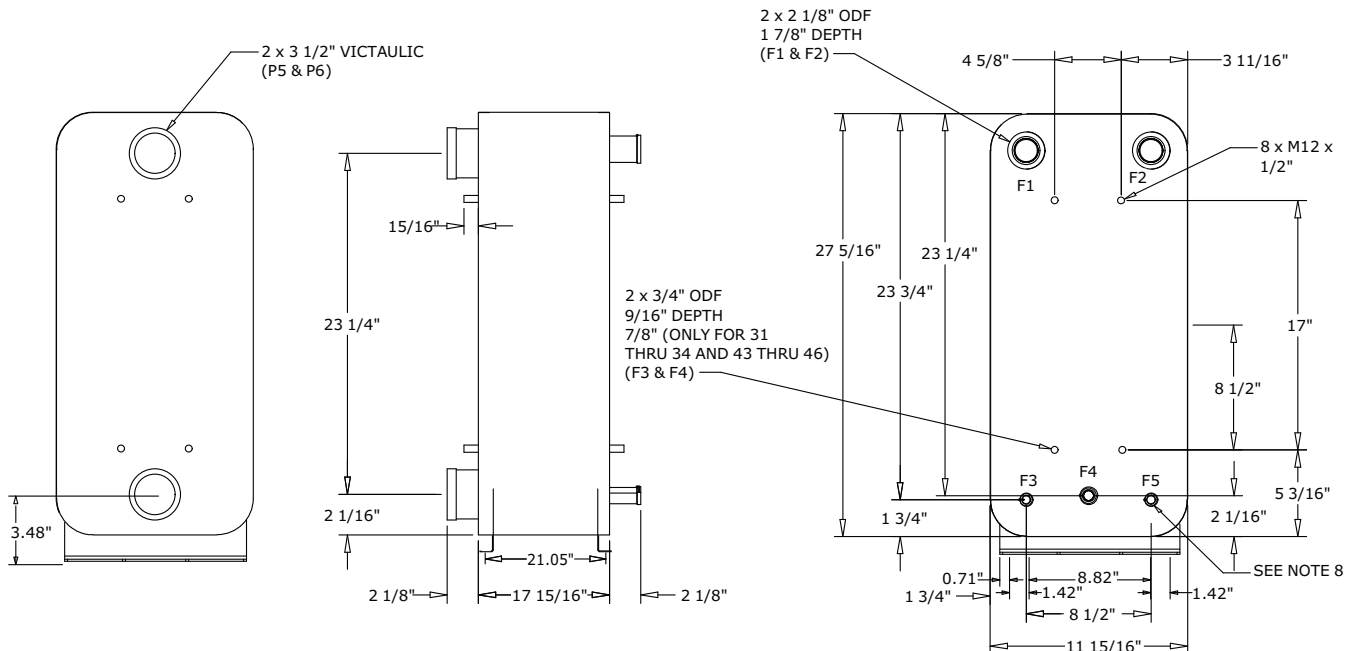

100 TON BRAZED PLATE HEAT EXCHANGER

ACCESSORY DRAWING



Dimensions and Weights

Figure 27. Evaporator chiller — 120 ton

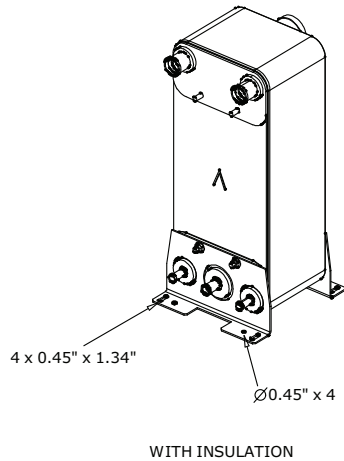

NOTES:

1. THIS HEAT EXCHANGER IS INTENDED FOR INDOOR INSTALLATION ONLY
2. HEAT EXCHANGER MOUNTING LEGS ARE INSTALLED AT JOB SITE WITH SUPPLIED FASTENERS
3. INSULATION SHOULD BE INSTALLED AFTER INSTALLING LEGS & REFRIGERANT TUBING, OR MUST BE ADEQUATELY SHIELDED AGAINST HEAT WHEN BRAZING REFRIGERANT LINES
4. INSTALL INSULATION SIDE PIECES FIRST THEN WRAPPER (MAY REQUIRE TRIMMING)
5. USE VINYL TAPE (FIELD SUPPLIED) TO SEAL INSULATION AFTER INSTALLATION
6. WATER CONNECTIONS ARE GROOVED (VICTAULIC)
7. REFRIGERANT CONNECTIONS ARE STAINLESS STEEL AND REQUIRE SPECIAL BRAZE MATERIALS. SEE IOM BRAZE PROCEDURE.
8. 1/2" - 14 NPT F5 CONNECTION SUPPLIED ON EXT'S 13 THRU 24 AND 37 THRU 48 ONLY.

BRAZED PLATE HEAT EXCHANGER REMOTE CHILLER EVAPORATOR OPTION

OPTION INCLUDES:

- 1 - BRAZED PLATE HEAT EXCHANGER - SHIPS SEPARATE FROM RAUJ CONDENSING UNIT
- 1 - INSTALLATION KIT, TO INCLUDE:
 - 2 - MOUNTING BRACKETS
 - 1 - INSULATION KIT
 - 1 - MOUNTING BRACKET & INSULATION KIT INSTALLATION INSTRUCTIONS
- 1 - WATER CONNECTION KIT WITH PIPING STUBS, Y CONNECTOR, STRAINER, VICTAULIC CONNECTIONS WITH GASKETS, WATER FLOW SWITCH
- 1 - WATER CONNECTION KIT INSTALLATION INSTRUCTIONS

INSTALLATION ADDITIONALLY REQUIRES:

- RAUJ REMOTE EVP CONTROL PANEL WITH LEAVING WATER TEMPERATURE SENSOR, FREEZE-STAT, AND INSTALLATION INSTRUCTIONS - ALL INCLUDED WITH REMOTE EVP CONTROL PANEL
- 4 - FIELD PROVIDED 7/16" BOLTS FOR SECURING BRAZED PLATE HEAT EXCHANGER TO PERMANENT MOUNTING SURFACE
- 2 - FIELD PROVIDED 1/2" - 14 NPT PLUGS, STAINLESS STEEL OR PVC
- FIELD PROVIDED TEFLON TAPE FOR SEALING 1/2" PIPE PLUGS
- FIELD PROVIDED WATER STRAINER PLUG OR BLOW DOWN VALVE
- FIELD PROVIDED TEE FOR INSTALLING WATER FLOW SWITCH
- FIELD PROVIDED 2" VINYL TAPE FOR SEALING INSULATION SEAMS

SEE IOM FOR INSTALLATION DETAIL

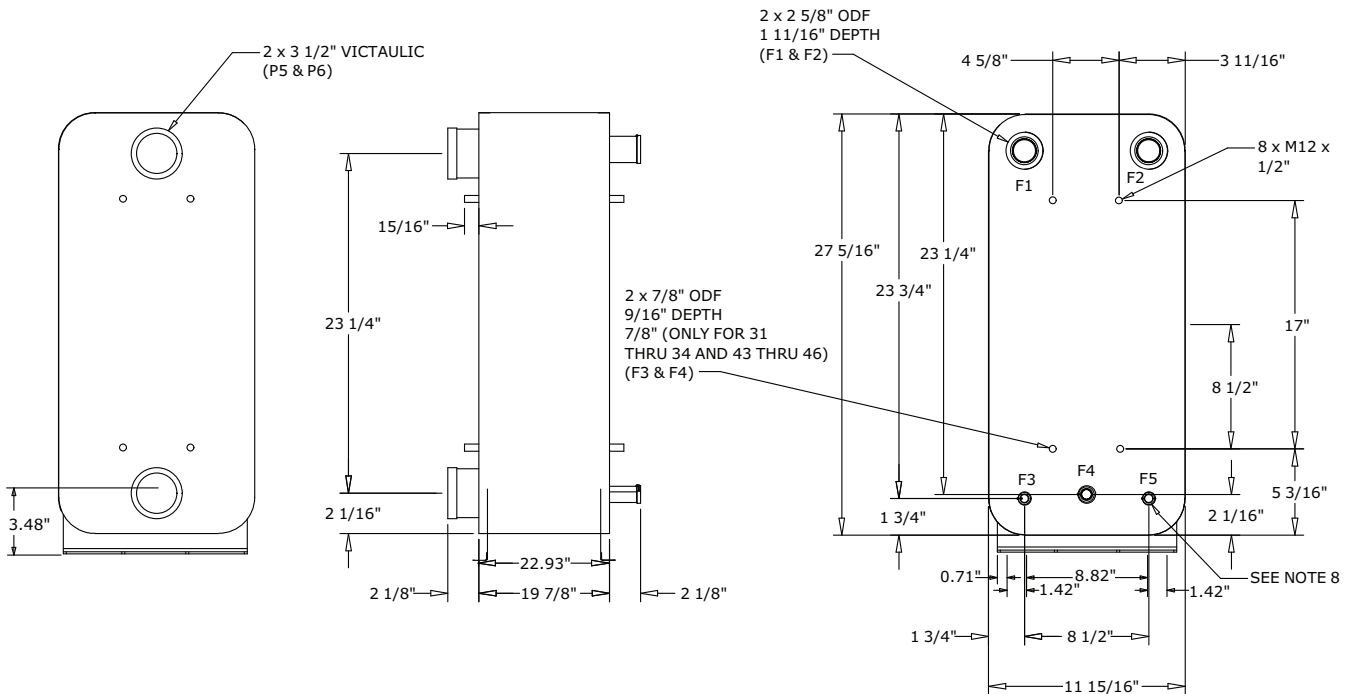

120 TON BRAZED PLATE HEAT EXCHANGER

ACCESSORY DRAWING

Unit Weights

Table 4. RAUJ condensing unit weights

Unit Size (tons)	Weights (lbs)	
	Shipping	Operating
20	1548	1573
25	1598	1623
30	1598	1623
40	2482	2532
50	2826	2868
60	2803	2853
80	4870	4940
100	5539	5622
120	5995	6121

Table 5. EVP remote chiller weights

Unit Size (tons)	Weights (lbs)	
	Shipping	Operating
20	54	67
25	86	105
30	116	144
40	92	134
50	138	207
60	160	245
80	212	332
100	298	475
120	327	524



Installation Mechanical

Location Requirements

Isolation

To minimize unit sound and vibration transmission, one of the following installation methods should be used:

- Install the unit directly on an isolated (detached) concrete pad or on isolated concrete footings located at each unit load point. OR
- Install the optional neoprene or spring isolators at each mounting location. See Unit Isolation section.

Foundation

Ground Level Installation

- If the unit is installed at ground level, elevate it above the snow line.
- Provide concrete footings at each support location or a slab foundation for support.
- See Weights table in Dimensions and Weights chapter for the unit operating weights.
- See Unit Mounting section for mounting locations and point loading weights when constructing the footing foundation.
- Anchor the unit to the footings or slab using hold down bolts or isolators.
- Isolators should be installed to minimize the transmission of vibrations into the building. See Unit Isolation section.

Rooftop Applications

For rooftop applications, ensure the roof is strong enough to support the unit. See Weights table in Dimensions and Weights chapter for the unit operating weights.

Anchor the unit to the roof with hold-down bolts or isolators. Follow the instructions in Unit Isolation section for proper isolator placement and installation.

Check with a roofing contractor for proper waterproofing procedures.

Leveling the Unit

Before tightening the mounting bolts, level the unit carefully. Use the unit base rail as a reference. Level the unit to within 1/4 inch over its entire length. Use shims if non-adjustable isolators (neoprene) are used.

If adjustable isolators (spring) are used, ensure that the proper isolator housing clearance is maintained while

leveling the unit. Isolators are identified by color and/or an isolator part number. Shims under the isolators may be required if the unit cannot be leveled using the isolator leveling bolt.

Rigging and Lifting

⚠ WARNING

Heavy Object!

Failure to follow instructions below could result in unit dropping which could result in death or serious injury, and equipment or property-only damage.

Ensure that all the lifting equipment used is properly rated for the weight of the unit being lifted. Each of the cables (chains or slings), hooks, and shackles used to lift the unit must be capable of supporting the entire weight of the unit. Lifting cables (chains or slings) may not be of the same length. Adjust as necessary for even unit lift.

⚠ WARNING

Improper Unit Lift!

Failure to properly lift unit in a LEVEL position could result in unit dropping and possibly crushing operator/technician which could result in death or serious injury, and equipment or property-only damage.

Test lift unit approximately 24 inches (61 cm) to verify proper center of gravity lift point. To avoid dropping of unit, reposition lifting point if unit is not level.

See Weights table in Dimensions and Weights chapter for unit weights. See [Table 6, p. 42](#) for center-of-gravity information.

1. Rig condensing unit as shown in [Figure 28, p. 41](#) and [Figure 29, p. 41](#). Attach adequate strength lifting slings to all four lifting brackets. Do not use cables, chains, or slings except as shown.
2. Install spreader bars as shown in [Figure 28, p. 41](#) to protect the unit and to facilitate a uniform lift. Minimum distance between lifting hook and top of unit is 7 feet.
3. Test-lift the unit to ensure it is properly rigged and balanced. Make any necessary rigging adjustments.
4. Lift the unit and position into place.

Figure 28. Rigging and center-of-gravity data

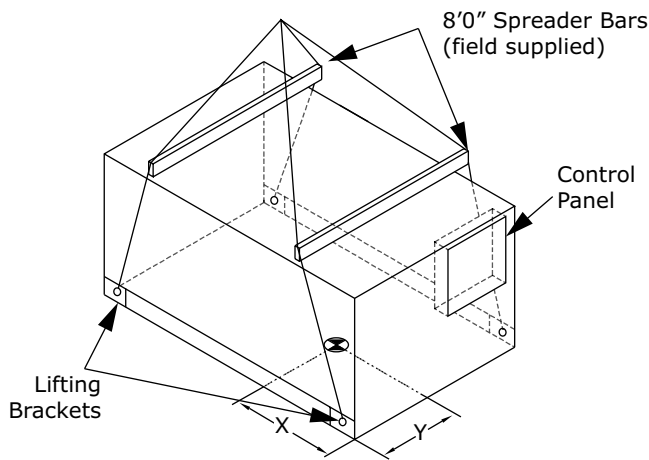

Note: See lifting bracket location figure for more detail.

Figure 29. Lifting bracket locations

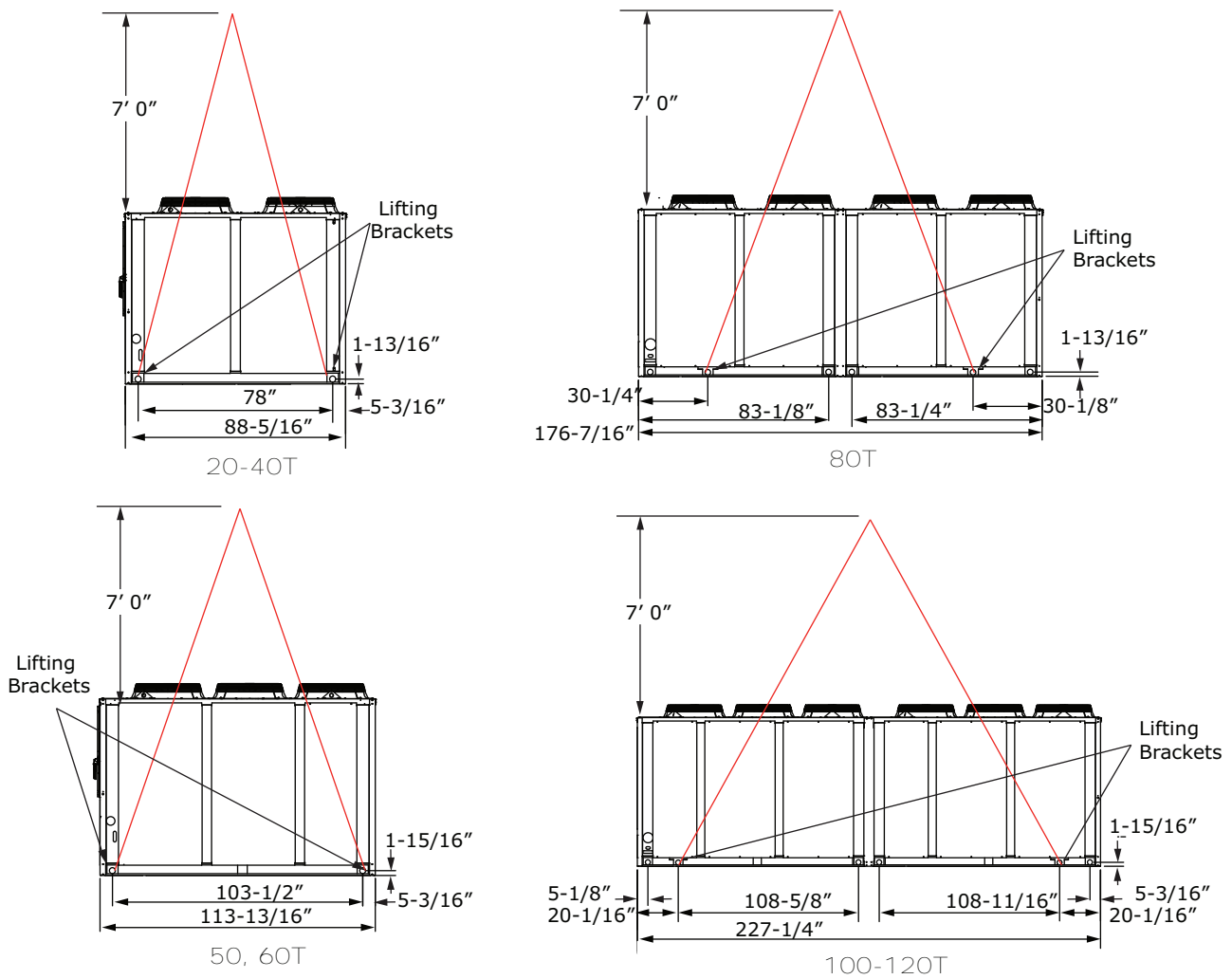



Installation Mechanical

Table 6. RAUJ center-of-gravity

Tons	CG Locations	
	X	Y
20	40.8	33.0
25	40.6	32.8
30	40.6	32.8
40	43.4	46.0
50	52.3	45.9
60	52.1	45.9
80	86.0	55.8
100	110.9	55.0
120	111.5	54.2

Unit Mounting

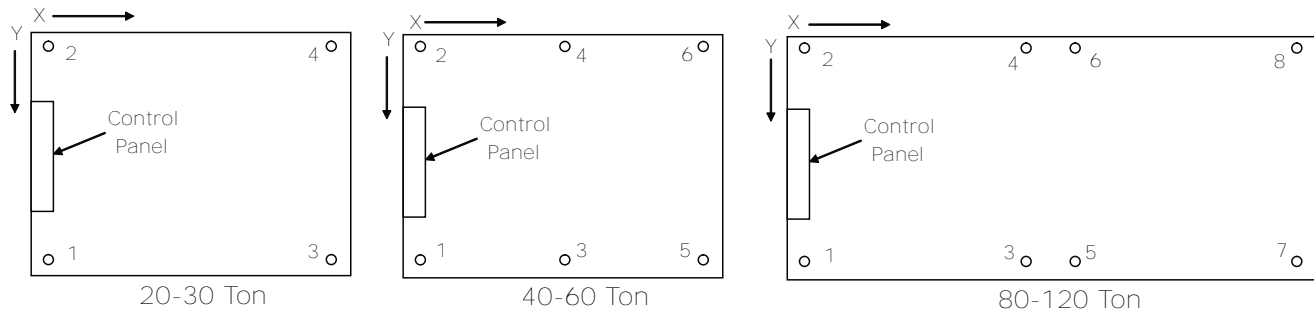
Figure 30. Mounting location

Table 7. Isolator mounting locations (in)

Unit Size (tons)		Mounting Location							
		1	2	3	4	5	6	7	8
20/25/30	X	8.00	8.00	80.125	80.125	-	-	-	-
	Y	58.75	1.25	58.75	1.25	-	-	-	-
40	X	8.00	8.00	44.125	44.125	80.25	80.25	-	-
	Y	87.125	1.25	87.125	1.25	87.125	1.25	-	-
50/60	X	8.00	8.00	56.875	56.875	105.75	105.75	-	-
	Y	87.125	1.25	87.125	1.25	87.125	1.25	-	-
80	X	8.00	8.00	80.125	80.125	108.125	108.125	168.25	168.25
	Y	87.125	1.25	87.125	1.25	87.125	1.25	87.125	1.25
100/120	X	8.00	8.00	105.625	105.625	121.625	121.625	219.25	219.25
	Y	87.125	1.25	87.125	1.25	87.125	1.25	87.125	1.25

Table 8. RAUJ point loading weights (lbs)

Unit Size (tons)		Mounting Location							
		1	2	3	4	5	6	7	8
20		475.5	383.3	403.2	311.0	—	—	—	—
25		491.2	399.3	412.2	320.3	—	—	—	—
30		491.2	399.3	412.2	320.3	—	—	—	—
40		452.3	415.7	440.3	403.7	428.3	391.8	—	—
50		365.5	331.0	427.8	393.3	700.1	650.3	—	—
60		367.2	332.8	426.0	391.6	692.5	642.9	—	—
80		798.3	462.1	786.7	450.5	785.1	448.9	772.4	436.1
100		871.1	609.5	881.0	616.2	882.6	432.1	892.5	436.8
120		988.2	614.7	948.3	587.4	941.8	583.0	901.8	555.8

Unit Isolation

Neoprene Isolators (20 to 60 Ton units)

Figure 31. Neoprene isolators (20 to 60 ton units only)

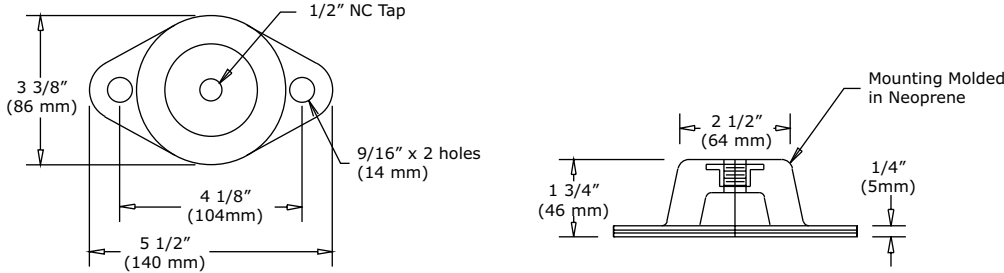

Table 9. RAUJ neoprene isolator selection (20 to 60 ton units only)

Unit Size (tons)	Mounting Location					
	1	2	3	4	5	6
20	R-3-RED	R-3-RED	R-3-RED	R-3-RED	-	-
25	R-3-RED	R-3-RED	R-3-RED	R-3-RED	-	-
30	R-3-RED	R-3-RED	R-3-RED	R-3-RED	-	-
40	R-3-RED	R-3-RED	R-3-RED	R-3-RED	R-3-RED	R-3-RED
50	R-3-RED	R-3-RED	R-3-RED	R-3-RED	R-3-GREEN	R-3-GREEN
60	R-3-RED	R-3-RED	R-3-RED	R-3-RED	R-3-GREEN	R-3-GREEN

⚠ WARNING

Heavy Object!
 Failure to follow instructions could result in death or serious injury.
 Use solid type blocks, such as 4 X 4 inch wood blocks or similar material, to prevent collapsing. Keep hands and other body limbs clear of elevated base rail while installing isolators.

Install the neoprene isolators at each unit mounting (load) point, using the following procedure:

1. Elevate the unit (one side at a time) to allow access to the base rail mounting holes.
2. Align the mounting holes in the base rail of the unit with the holes in the top of the appropriate isolator.
3. Install a 1/2" NC bolt (field supplied) through the

base rail of the unit into the threaded bolt hole of the isolator. Position the isolator to allow access to the mounting holes in the base of the isolator, then tighten securely.

4. Lower the unit and isolator onto the mounting surface. The maximum isolator deflection should be approximately 1/4 inch.
5. Secure the isolator to the mounting surface using the base holes in the isolator.
6. Level the unit carefully. See the Leveling the Unit section earlier in this chapter.
7. After the unit is level, tighten the isolator base mounting bolts to secure them to the mounting surface.

Spring Isolators (20 to 120 Ton units)

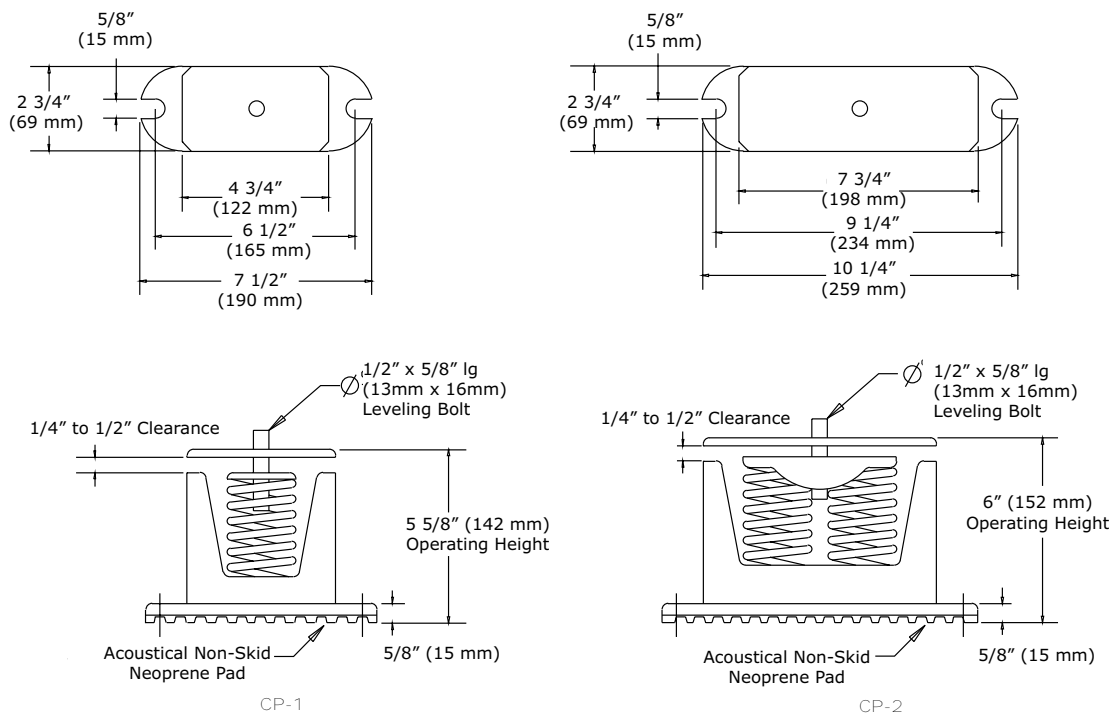
Figure 32. Spring isolators

Table 10. RAUJ spring isolator selection

Unit Size (tons)	Mounting Location							
	1	2	3	4	5	6	7	8
20	CP-1D-510	CP-1D-510	CP-1D-510	CP-1D-340	-	-	-	-
25	CP-1D-510	CP-1D-510	CP-1D-510	CP-1D-340	-	-	-	-
30	CP-1D-510	CP-1D-510	CP-1D-510	CP-1D-340	-	-	-	-
40	CP-1D-510	CP-1D-510	CP-1D-510	CP-1D-510	CP-1D-510	CP-1D-510	-	-
50	CP-1D-510	CP-1D-340	CP-1D-510	CP-1D-510	CP-1D-900	CP-1D-675	-	-
60	CP-1D-510	CP-1D-340	CP-1D-510	CP-1D-510	CP-1D-900	CP-1D-675	-	-
80	CP-1D-900	CP-1D-510	CP-1D-900	CP-1D-510	CP-1D-900	CP-1D-510	CP-1D-900	CP-1D-510
100	CP-1D-900	CP-1D-675	CP-1D-900	CP-1D-675	CP-1D-900	CP-1D-510	CP-1D-900	CP-1D-510
120	C2P-1D-1020	CP-1D-675	C2P-1D-1020	CP-1D-675	C2P-1D-1020	CP-1D-675	C2P-1D-1020	CP-1D-675

⚠ WARNING

Heavy Object!

Failure to follow instructions could result in death or serious injury.

Use solid type blocks, such as 4 X 4 inch wood blocks or similar material, to prevent collapsing. Keep hands and other body limbs clear of elevated base rail while installing isolators.

Install the spring isolators at each unit mounting (load) point, using the following procedure:

1. Elevate the unit (one side at a time) to allow access to the base rail mounting holes.
2. Align the mounting holes in the base rail of the unit with the positioning pin in the top of the appropriate isolator.
3. Position the isolator to allow access to the mounting holes in the base of the isolator.
4. Lower the unit onto the isolator. The positioning pin on the isolator must engage into the hole of the base rail. The clearance between the upper and lower isolator housings should be approximately 1/



Installation Mechanical

4 to 1/2 inch. A clearance greater than 1/2 inch indicates that shims are required to level the unit. See Leveling the Unit section earlier in this chapter.

5. Make minor clearance adjustments by turning the isolator leveling bolt clockwise to increase the clearance and counterclockwise to decrease the clearance. If proper isolator clearance cannot be obtained by turning the leveling bolt, level the isolators themselves. A 1/4 inch variance in elevation is acceptable.
6. Secure the isolator to the mounting surface using the base holes in the isolator.
7. After unit is level, tighten isolator base mounting bolts to secure them to the mounting surface.

Installation

General Unit Requirements

The checklist listed below is a summary of the steps required to successfully install a commercial air cooled condenser. This checklist is intended to acquaint the installing personnel with what is required in the installation process. It does not replace the detailed instruction called out in the applicable sections of this manual.

- Install freezestat well and freezestat bulb in water.
- Verify that the power supply complies with the unit nameplate specifications.
- Check the unit for shipping damage and material shortage. If damage or shortage is found, file a freight claim and notify Trane office.
- Verify installation location of the unit will provide the required clearance for proper operation.

- Install appropriate isolators, if required.

Refrigerant Piping Requirements

Note: See *Refrigerant Piping Component and Refrigerant Piping sections and for recommended line components and guidelines.*

- Install properly sized liquid line(s) between the liquid line connections on the unit and the evaporator.
- Install a properly sized liquid line isolation solenoid valve in each liquid line.
- Install refrigerant rated shutoff valves in the liquid line(s) to isolate the filter drier(s) for service.
- Install a properly sized filter drier in each liquid line.
- Install properly sized suction line(s) between the suction line connections on the unit and the evaporator.
- Install a properly sized filter in each suction line.
- Install properly sized hot gas bypass line(s) between the hot gas bypass connections on the unit and the evaporator.
- Insulate the suction line.
- See Installation EVP chapter for chiller installation instructions.
- Leak test the system per Leak Testing Procedure section.

Refrigerant Piping Components

For recommended components, see the latest edition of the Applications Guide SS-APG012-EN.

Figure 33. Typical placement of split system piping components

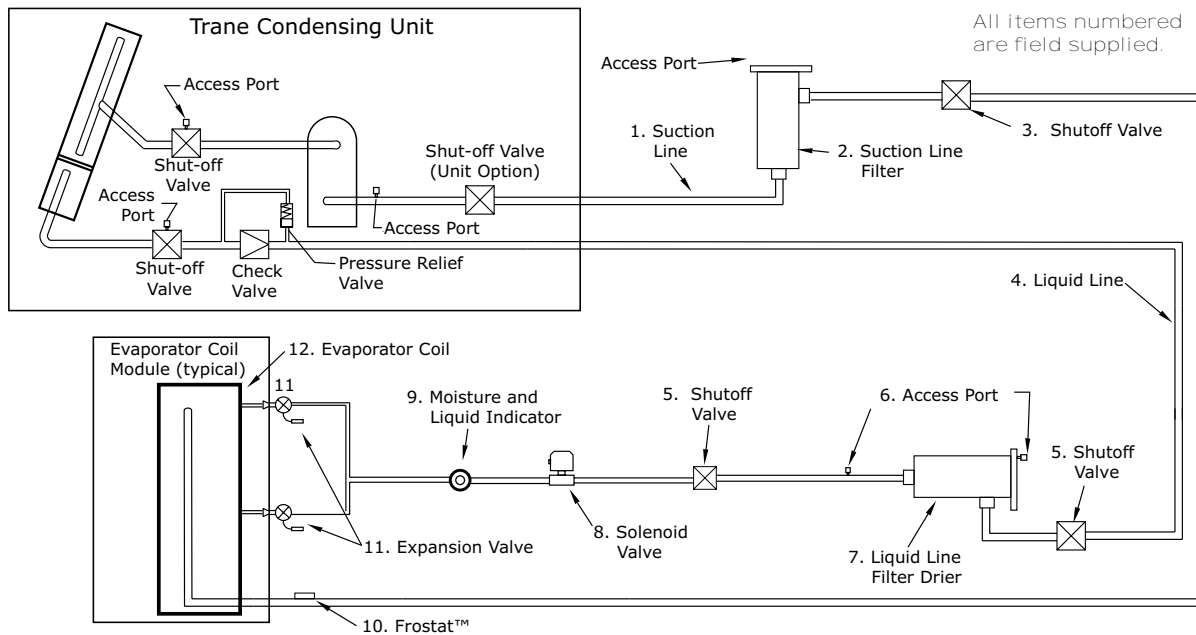

Table 11. Component number descriptions

Component	Description
1	Interconnecting Suction Line Tubing
2	Suction Line Filter
3	Shutoff Valves - Manual ball valves
4	Interconnecting Liquid Line Tubing. If risers exceed 10 feet, Trane must review the application
5	Shutoff valves - Manual ball valves
6	Access Ports
7	Liquid Line Filter Drier
8	Liquid Line Solenoid Valve
9	Moisture and Liquid Indicator
10	Frostat™ (Required for coil freeze protection)
11	Expansion Valve (One Expansion Valve for each Coil Distributor)
12	Evaporator Coil

Suction Line Components

Suction line refrigerant components necessary for field installation in the suction line are a filter (Core Type), access valves (ports), Frostat™ control for coil frost protection, and ball shutoff valves. See [Figure 33, p. 47](#) for placement location.

Suction Filter/Filter Drier (Field Supplied)

Install the filter in the suction line upstream of the compressors. To prevent oil accumulation, suction

filters should be installed vertical with the outlet at the bottom or no more than 45° from vertical.

Ball Shutoff Valves

The ball shutoff valve allows for isolation of the Filter/Filter Drier for easier core replacement.

Two ball shutoff valves equal to the OD Tubing size for suction line are required.

Access Valves (Ports)

The access ports in the suction line allow the operating suction pressure to be checked across the suction line filter. These ports are usually a Schrader valve with core.

Frostat Coil Frost Protection

The Frostat™ control is the preferred method of coil frost protection. The Frostat control bulb is mechanically attached to the suction line near the evaporator and wired to the unit control panel. See field connection diagram for details.

Liquid Line Components

The required liquid line refrigerant components include a filter drier (Core Type), access valve(s) or (ports), solenoid valve(s), moisture indicating sight glass, expansion valve(s), and ball shutoff valve(s). See [Figure 33, p. 47](#) for placement location.

Liquid Line Filter/Filter Drier (Field Supplied)

Install the filter drier in the liquid line as close as possible to the expansion valve. Locate them upstream of the moisture indicator and solenoid valve (if applicable).



Installation Mechanical

Liquid Line Moisture Indicator Sight Glass

To aid in troubleshooting, install a moisture indicator sight glass in the liquid line near the evaporator, downstream of the solenoid valve prior to any branch takeoffs to the expansion valve. The sight glass should not be used to determine adequate refrigerant charge. Liquid temperature and discharge pressure measurements are required to determine the proper charge. Note that under some conditions, charging until the sight glass is solid liquid will overcharge the system and reduce compressor reliability. See Compressor Start-up section for proper system charging.

Liquid Line Solenoid Valves

NOTICE

Equipment Damage!

Do not use solenoid valve as a pumpdown device as it could result in equipment damage.

Liquid line isolation solenoid valves (one per refrigeration circuit) are required for refrigerant

migration control into evaporator during "Off" cycle and should be connected as illustrated in applicable field connection diagram.

Thermostatic Expansion Valve (TXV)

Trane recommends a balance-ported externally equalized valve in order to maintain satisfactory superheat control down to lower valve loading conditions and to compensate for pressure drops between the expansion valve and superheat control point (evaporator refrigerant outlet). For fin and tube evaporator applications, a 30% bleed port TXV is required for 20 to 60 ton units and a 15% bleed port is required for 80 to 120 ton units.

In order to get proper refrigerant distribution into the coil, an expansion valve is required for each coil distributor. See tables below for valve selection.

Table 12. Expansion valve selection, any BPHE all Fin and Tube OD coils (0% bleed)

Min Tonnage	Max Tonnage	Selection ^(a)	Alternate ^(a)
1.5	2	BBIZE-1-1/2-GA	ERZE-1-1/2-GA
2	3	BBIZE-2-GA	ERZE-2-GA
2.5	4	BBIZE-3-GA	ERZE-3-GA
3.5	5.5	BBIZE-4-GA	ERZE-4-GA
4.5	6.5	BBIZE-5-GA	ERZE-5-GA
5.5	7.5	BBIZE-6-GA	ERZE-6-GA
6.5	10.5	BBIZE-8-GA	ERZE-8-GA
8.5	13.5	BBIZE-12-1/2-GA	ERZE-12-1/2-GA
11	16.5	BBIZE-15-GA	ERZE-15-GA
13	22	OZE-20-GA	n/a
17	26	OZE-25-GA	n/a
20.5	39	OZE-35-GA	n/a
30.5	59	OZE-50-GA	n/a
45.5	70	OZE-60-GA	n/a

^(a) Valve part numbers with "-ZGA" in place of "-GA", may be used interchangeably.

Table 13. Expansion valve selection, 20 to 60 ton MCHE (30% bleed)

Min Tonnage	Max Tonnage	Manufacturer	Selection ^(a)	Trane Part
2	3	Sporlan	ERZE-1-1/2-ZGA (BP/15)	VAL10487
2.5	3.5	Sporlan	ERZE-2-ZGA (BP/30)	VAL10488
3.5	5	Sporlan	ERZE-3-ZGA (BP/30)	VAL10489
4.5	7	Sporlan	ERZE-4-ZGA (BP/30)	VAL10490

Table 13. Expansion valve selection, 20 to 60 ton MCHE (30% bleed) (continued)

Min Tonnage	Max Tonnage	Manufacturer	Selection ^(a)	Trane Part
6	8.5	Sporlan	ERZE-5-ZGA (BP/30)	VAL10491
7	10	Sporlan	ERZE-6-ZGA (BP/30)	VAL10492
8	13.5	Sporlan	ERZE-8-ZGA (BP/30)	VAL10493
11	17.5	Sporlan	ERZE-12-1/2-ZGA (BP/30)	VAL10494
14	21.5	Sporlan	ERZE-15-ZGA (BP/30)	VAL10495
17	28.5	Sporlan	OZE-20-ZGA (BP/30)	VAL10496
22	30	Sporlan	OZE-25-ZGA (BP/30)	VAL10497

^(a) Valve part numbers with "-ZGA" in place of "-GA", may be used interchangeably.

Table 14. Expansion valve selection, 80 to 120 ton MCHE (15% bleed)

Min Tonnage	Max Tonnage	Manufacturer	Selection ^(a)	Trane Part
2	2.5	Sporlan	ERZE-1-1/2-ZGA (BP/15)	n/a
2.5	3	Sporlan	ERZE-2-ZGA (BP/15)	n/a
3	4.5	Sporlan	ERZE-3-ZGA (BP/15)	n/a
4	6	Sporlan	ERZE-4-ZGA (BP/15)	n/a
5	7.5	Sporlan	ERZE-5-ZGA (BP/15)	VAL10579
6	9	Sporlan	ERZE-6-ZGA (BP/15)	VAL10580
7	12	Sporlan	ERZE-8-ZGA (BP/15)	VAL10581
9.5	15.5	Sporlan	ERZE-12-1/2-ZGA (BP/15)	VAL10582
12.5	19	Sporlan	ERZE-15-ZGA (BP/15)	VAL10583
15	25	Sporlan	OZE-20-ZGA (BP/15)	VAL10584
19.5	30	Sporlan	OZE-25-ZGA (BP/15)	VAL10585
23.5	45	Sporlan	OZE-35-ZGA (BP/15)	VAL10586
35	68	Sporlan	OZE-50-ZGA (BP/15)	VAL10587
52.5	70	Sporlan	OZE-60-ZGA (BP/15)	VAL10588

^(a) Valve part numbers with "-ZGA" in place of "-GA", may be used interchangeably.

TXV for Remote Chiller

See Installation EVP chapter for piping between TXV and remote chiller.

Ball Shutoff Valves

The ball shutoff valve allows for isolation of the filter/filter drier for easier core replacement.

Two ball shutoff valves equal to the OD tubing size for liquid line are required.

Access Valves (Ports)

The access ports in the liquid line allows the unit to be charged with liquid refrigerant and is used to determine sub-cooling.

Refrigerant Piping

NOTICE

Compressor Damage!

POE oil is hygroscopic – it absorbs water directly from the air. This water is nearly impossible to remove from the compressor oil and can result in compressor failures.

To prevent POE oil from absorbing water, the system should not remain open for longer than necessary. When open, dry nitrogen should flow through the piping. Only new oil containers should be used for service and maintenance. Always use the smallest container size required for the job requirements. Always leave the oil container tightly sealed until time of use. Do not reuse oil that has been opened.

Refrigerant piping must be properly sized and applied. These two factors have a very significant effect on both system performance and reliability.

Note: Use Type "L" refrigerant grade copper tubing only.

Refrigerant Piping should be sized and laid out according to the job plans and specifications. This should be done when the system components are selected.

Suction Line Piping

Proper suction line sizing is required to guarantee that oil is returned to the compressor throughout the operating system. Furthermore, the line must be sized so that the pressure drop does not excessively affect capacity or efficiency. To accomplish both, it may be necessary to have two sizes, one for horizontal run and vertical drops, and another for the vertical lifts. The preselected suction line sizes shown in the table below are independent of line length for a properly charged RAUJ unit operating in a normal air conditioning application.

Table 15. Suction line interconnecting tubing

Capacity	OD unit connection (Per circuit)	Recommended field piping	
		OD Horizontal (Per Circuit)	OD Vertical (Per Circuit)
20 Ton	1-5/8"	1-5/8"	1-5/8"
25 Ton	1-5/8"	2-1/8"	1-5/8"
30 Ton	1-5/8"	2-1/8"	2-1/8"
40 Ton	1-5/8"	1-5/8"	1-5/8"
50 Ton	1-5/8"	2-1/8"	1-5/8"
60 Ton	2-1/8"	2-1/8"	2-1/8"
80 Ton	2-5/8"	2-1/8"	2-1/8"
100 Ton	2-5/8"	2-5/8"	2-1/8"
120 Ton	2-5/8"	2-5/8"	2-1/8"

Note: If risers exceed 50 feet, the application must be reviewed by Trane.

For more information, refer to the latest edition of Application Guide SS-APG012-EN.

- Do not use suction line traps.
- Do not use double risers.
- Avoid putting liquid lines underground.
- Route suction lines as short and direct as possible.
- Slope suction lines toward the evaporator ¼-inch to 1-inch for every 10 feet.
- Insulate the suction lines.
- The suction line filter should be as close to the compressor as possible.

Note: If Suction Riser Exceeds 50 Feet, Trane Must Review The Application.

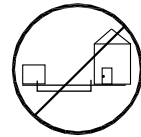
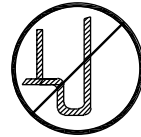

Liquid Line Piping

Oversized liquid lines reduce compressor reliability due to excess refrigerant in the system, and system operation becomes more charge critical due to liquid thermal expansion into the condenser at higher ambients. Conversely, liquid line OD needs to be big enough to allow for adequate subcooling entering the expansion valve at high load conditions. The preselected line sizes shown in the table below are independent of line length or rise within the limitations of the latest edition of the Application Guide SS-APG012-EN.

Table 16. Liquid line interconnecting tubing

Capacity	OD unit connection (Per Circuit)	Recommended field piping	
		OD Horizontal (Per Circuit)	OD Vertical (Per Circuit)
20 Ton	7/8"	5/8"	5/8"
25 Ton	7/8"	7/8"	7/8"
30 Ton	7/8"	7/8"	7/8"
40 Ton	7/8"	5/8"	5/8"
50 Ton	7/8"	7/8"	7/8"
60 Ton	7/8"	7/8"	7/8"
80 Ton	1-1/8"	1-1/8"	1-1/8"
100 Ton	1-1/8"	1-1/8"	1-1/8"
120 Ton	1-1/8"	1-1/8"	1-1/8"

Note: If risers exceed 10 feet, refer to Tube Size and Component Selection, publication SS-APG012-EN.

The liquid line should have a slight slope in the direction of flow so that it can be routed with the suction line.

The unit has a liquid line check valve that prevents liquid refrigerant from flowing backward through the liquid line, filling the condenser, and overflowing to the compressor during the “Off” cycle. A relief valve is also installed to prevent the buildup of high pressure in the liquid line when the unit is off. For proper operation of the relief valve, the liquid line service valve should not be in the back seated position but cracked open so the relief valve (and the fan pressure switch) is open to the condenser. The line that connects the outlet of the 235 psig relief valve to the liquid line service valve must not be removed.

For more information, refer to the latest edition of Application Guide SS-APG012-EN.

- Avoid putting liquid lines underground.
- Route liquid lines as short and direct as possible.
- Slope liquid lines away from the condensing unit 1-inch for every 10 feet.
- Only insulate liquid lines that pass through heated areas.
- Wire solenoid valves according to the field connection diagram for proper operation.
- The liquid line filter drier should be as close to the solenoid valve as possible.

Note: If the liquid line riser exceeds 10 feet, refer to *Tube Size and Component Selection*, publication number SS-APG012-EN

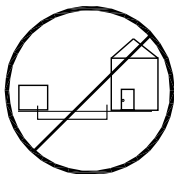

Figure 34. Face-split

Typical Field-Installed Evaporator Piping: Dual-Circuit Examples

1. Install the TXV directly to the unit liquid connection.
2. Locate the TXV bulb midway between the 90 degrees bends on top of the suction line as illustrated in Figure 34, p. 51 or Figure 35, p. 52.
3. Secure bulb to suction line with two clamps provided by manufacturer and insulate bulb.
4. Install the Froststat™ according to instructions enclosed in the kit as close to evaporator as possible. Although it may look like a trap, it is the result of going down past the last outlet and turning to go up.

Note: All 20 to 60 ton units will require 30% bleed TXVs. All 80 to 120 ton units will require 15% bleed TXVs. This does not apply if they are connected to remote chiller evaporators (see next section).

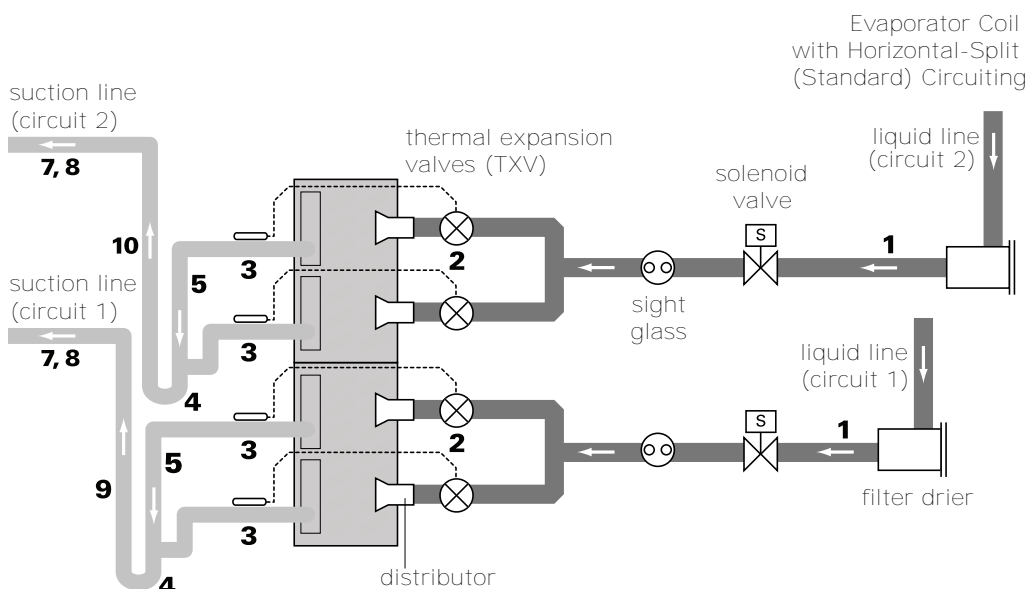
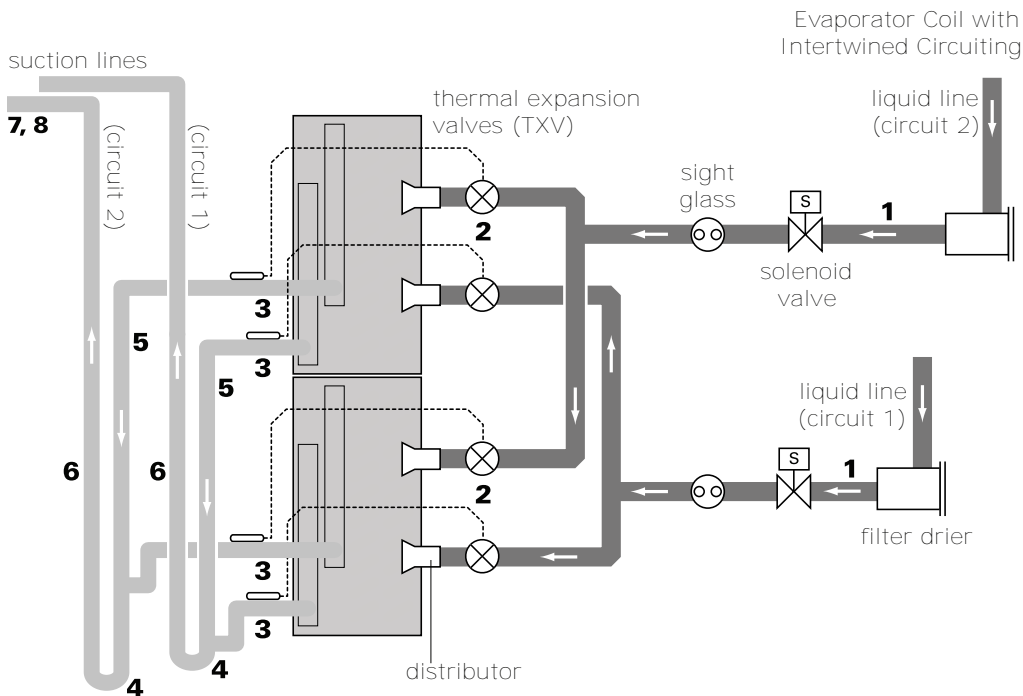

Figure 35. Intertwined



Hot Gas Bypass for Commercial Comfort-Cooling Applications

Hot gas bypass is not recommended for use on RAUJ units. Froststat™ is the preferred method of protecting the evaporator from freeze-up. It turns off compressors when the coil frosting is sensed. The compressor is allowed to operate when the coil temperature rises a few degrees above the frosting condition. This action reduces the overall energy consumption of the system while reliably maintaining system control.

For more information, see Hot Gas Bypass Engineers Newsletter, ADM-APN007-EN.

Optional Pressure Gauges

When a unit is ordered with optional pressure gauges, (model number digit 16 = F), a set of gauges and the necessary mounting hardware ship with the unit. See General Information chapter for ship-with location on unit. The mounting location and tubing configuration for the optional pressure gauges after field installation is shown below.

1. Assemble the valve depressor, flare nuts, 1/4" copper tubing, 90 degree flare elbows, gauge & gauge bracket together as shown in Detail "A" & "B".

Note: Wrap all appropriate pipe threads with Teflon tape before assembly.

2. Remove the valve stem cap and place the valve depressor (with tubing connected) onto the valve stem and tighten.

Note: Do not install the valve depressor without the tubing being connected. If gauges need to be replaced, remove valve depressor from valve stem, first, to prevent loss of refrigerant charge.

3. Using the gauge bracket as a template for the self-tapping screws, mount the gauge bracket approximately 1/2" to 3/4" from the outer edge of the base rail, relative to the compressors for that circuit, as illustrated.
4. Apply 6" strips of edge protector to both side flanges of the gauge bracket, to prevent the bracket from cutting into the power wires.

Figure 36. Pressure gauges 20 - 60 Ton units: plan view

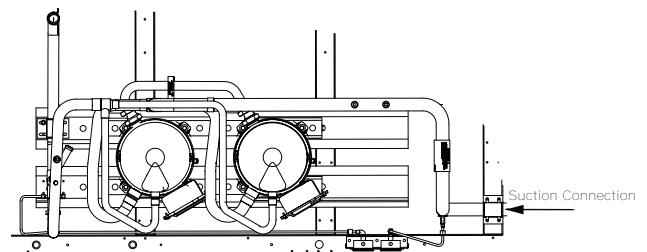

Figure 37. Pressure gauges 20 - 60 Ton units: front view

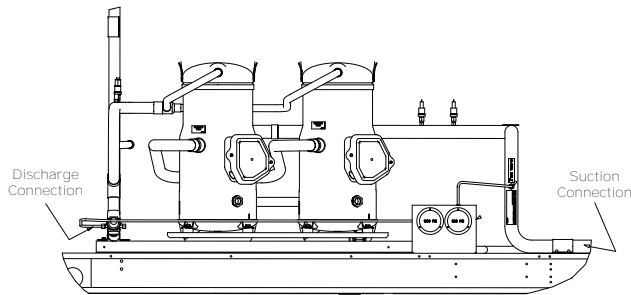
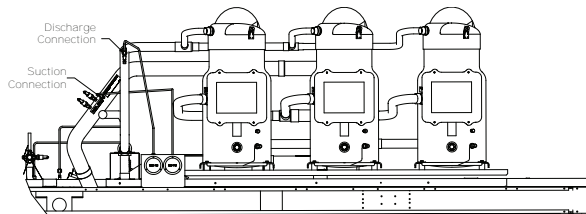

Figure 38. Pressure gauges 80 - 120 Ton units: front view



Final Refrigerant Pipe Connections

To access the refrigerant pipe connections, remove the louvered side grills. See connection drawings in Dimensions and Weights chapter..

These condensing units are shipped with a Nitrogen holding charge. Install pressure gauges to the appropriate access valve(s) and take a reading.

- If no pressure is present, see Leak Testing Procedure section.
- If pressure is present, relieve the pressure before attempting to unsweat the "seal" caps.
- If refrigerant connections are not capped, but are "spun-end" tubes, use a tubing cutter to remove the end from the pipe.

NOTICE

Equipment Damage!

Drilling or sawing pipe stubs could introduce copper chips into the system and cause equipment damage.

Do not drill a hole in the seal caps or saw the ends of pipe stubs.

Brazing Procedures

⚠ WARNING

Explosion Hazard and Deadly Gases!

Failure to follow all proper safe refrigerant handling practices could result in death or serious injury.

Never solder, braze or weld on refrigerant lines or any unit components that are above atmospheric pressure or where refrigerant may be present. Always remove refrigerant by following the guidelines established by the EPA Federal Clean Air Act or other state or local codes as appropriate. After refrigerant removal, use dry nitrogen to bring system back to atmospheric pressure before opening system for repairs. Mixtures of refrigerants and air under pressure may become combustible in the presence of an ignition source leading to an explosion. Excessive heat from soldering, brazing or welding with refrigerant vapors present can form highly toxic gases and extremely corrosive acids.

⚠ WARNING

Explosion Hazard!

Failure to follow these instructions could result in death or serious injury or equipment or property-only damage.

Use only dry nitrogen with a pressure regulator for pressurizing unit. Do not use acetylene, oxygen or compressed air or mixtures containing them for pressure testing. Do not use hydrogen mixtures containing refrigerant and air above atmospheric pressure for pressure testing as they may become flammable and could result in an explosion. Refrigerant, when used as a trace gas should only be mixed with dry nitrogen for pressurizing units.

Proper brazing techniques are essential when installing refrigerant piping. The following factors should be kept in mind when forming sweat connections.

- When copper is heated in the presence of air, copper oxide forms. To prevent copper oxide from forming inside the tubing during brazing, sweep an inert gas, such as dry nitrogen, through the tubing. Nitrogen displaces air in the tubing and prevents oxidation of the interior surfaces. A nitrogen flow of one to three cubic feet per minute is sufficient to displace the air. Use a pressure regulating valve or flow meter to control the flow.
- Ensure that the tubing surfaces to be brazed are clean, and that the ends of the tubes have been carefully reamed to remove any burrs.
- Make sure the inner and outer tubes of the joint are symmetrical and have a close clearance, providing an easy slip fit. If the joint is too loose, the tensile strength of the connection will be significantly

reduced. The overlap distance should be equal to the diameter of the inner tube.

- Wrap the body of each refrigerant line component with a wet cloth to keep it cool during brazing. Move any tube entrance grommets away for the brazing area.

Note: Use 40 to 45% silver brazing alloy (BAg-7 or BAg-28) on dissimilar metals. Use BCup-6 brazing alloy on copper to copper joints.

- If flux is used, apply it sparingly to the joint. Excessive flux can enter the system which will contaminate the refrigerant system.
- Apply heat evenly over the length and circumference of the joint to draw the brazing material into the joint by capillary action. Remove the brazing rod and flame from the joint as soon as a complete fillet is formed to avoid possible restriction in the line.
- Visually inspect the connection after brazing to locate any pin holes or crevices in the joint. The use of a mirror may be required, depending on the joint location.

Leak Testing Procedure

⚠ WARNING

Explosion Hazard!

Failure to follow these instructions could result in death or serious injury or equipment or property-only damage.

Use only dry nitrogen with a pressure regulator for pressurizing unit. Do not use acetylene, oxygen or compressed air or mixtures containing them for pressure testing. Do not use hydrogen mixtures containing refrigerant and air above atmospheric pressure for pressure testing as they may become flammable and could result in an explosion.

Refrigerant, when used as a trace gas should only be mixed with dry nitrogen for pressurizing units.

⚠ WARNING

Explosion Hazard!

Failure to follow safe leak test procedures below could result in death or serious injury or equipment or property-only-damage.

Never use an open flame to detect gas leaks. Use a leak test solution for leak testing.

When leak testing a refrigerant system, observe all safety precautions.

Trane condensing units are shipped with a nitrogen holding charge. If there is no pressure, the unit must be leak tested to determine the location of leak.

Note: These service procedures require working with refrigerant, Do NOT release refrigerant to the atmosphere! The service technician must comply with all federal, state, and local laws.

Use refrigerant gas as a tracer for leak detection and use oil-pumped dry nitrogen to develop the required test pressure. Test the high and low side of the system at pressures dictated by local codes.

1. Close the field supplied liquid line service valve(s) installed near the evaporator and the compressor discharge service valve to isolate the system's high side from the low side. Pressure test the liquid line, discharge line, and condenser coils at pressures dictated by local codes. Do not exceed 10# above the pressure control settings.
2. Connect a refrigerant cylinder to the charging port of the liquid line service valve. Use the refrigerant to raise the high side pressure to 12 to 15 psig.
3. Disconnect the refrigerant cylinder. Connect a dry nitrogen cylinder to the charging port and increase the high side pressure. Do not exceed the condenser maximum working pressure listed on the unit nameplate.
4. Use a leak detector or soap bubbles to check for leaks. Check all piping joints, valves, etc.
5. If a leak is located, use proper procedures to remove the refrigerant/nitrogen mixture, break the connection and remake as a new joint. Retest for leaks after making repairs.
6. Repeat the test procedure for the low side of the system, charging through the suction pressure gauge port or through an access provided on the suction line by the installer. Increase the system pressure to 100 psig.
7. If a leak is located, use proper procedures to remove the refrigerant/nitrogen mixture, break the connection and remake as a new joint. Retest for leaks after making repairs.
8. Open the liquid line service valve and the compressor discharge service valve.



Installation Mechanical – EVP

EVP Chilled Water Piping Requirements

- Install properly sized chilled water pipe between the EVP chiller and the supporting equipment. See Chilled Water Piping section for recommended system components and guidelines.
- Install supply and return water side pressure gauges (with isolation valves.)
- Install thermometers in water supply and return piping.
- Install isolation (shutoff) valves in water supply and return piping.
- Install a properly sized strainer in the supply piping.
- Install blowdown (recommended) valve or plug in strainer cleanout.
- Install a balancing valve in the return piping.
- Install a water flow switch in the return piping.
- Install chilled solution sensor well and sensor in the water outlet piping.
- Install freezestat well and freezestat bulb in the water outlet piping.
- Install chiller piping drain with shutoff valve.
- Install 1/2" x 14 NPT stainless steel or PVC plug in braze plate chiller body.
- Flush the chilled solution piping system, if applicable.
- Connect the chilled solution piping to the chiller.
- The braze plate chiller is intended for indoor application. If a subfreezing location is required, contact Trane for installation precautions required to prevent damage.
- If using an acidic, commercial flushing solution to prevent damage to the internal evaporator components, flush all chilled solution piping before making the final connection to the EVP chiller.

TXV for Remote Chiller

Piping between TXV and Chiller, a braze plate heat exchanger (BPHE), must be 8-12" long and same size as BPHE inlet ID. Field supplied reducer(s) may be required at TXV. A bleed port valve is not required with brazed plate heat exchanger applications.

Notes:

- *Install reducers at the TXV outlet only.*
- *See Dimensions and Weights chapter for BPHE inlet dimensions.*
- *See Expansion Valve Selection tables in the Installation Mechanical chapter for valve selections.*

Typical Field-Installed EVP Chiller Evaporator Piping

NOTICE

Heat Exchanger Damage!

Failure to follow instructions below could result in refrigerant leaks or damage to the heat exchanger. The braze connections at the heat exchanger are stainless steel. Use 40-45% silver brazing alloy BAg-7 or BAg-29 for copper to steel refrigerant connections. Use flux sparingly to prevent plugging heat exchanger flow passages.

1. Install the TXV(s) directly to the unit liquid connection. See TXV recommendations in the Tube Size and Component Selection Application Guide, publication number SS-APG012-EN.

NOTICE

Evaporator Damage!

Failure to follow instructions below could result in evaporator damage.

To prevent evaporator damage and for proper refrigerant distribution, an 8-12" stub tube must be brazed between the expansion valve and the chiller entering refrigerant connection. This tube must be the same diameter as the heat exchanger connection ID. Use reducers only at the expansion valve. See dimension drawings for inlet dimensions.

2. Locate TXV bulb on top of the suction line 12" from the heat exchanger outlet.
3. Secure the bulb to the suction line with two clamps provided by the manufacturer and insulate the bulb.
4. Locate liquid line solenoid valve(s) near TXV.
5. Install the Froststat™ according to instructions enclosed in the kit as close to the evaporator as possible.

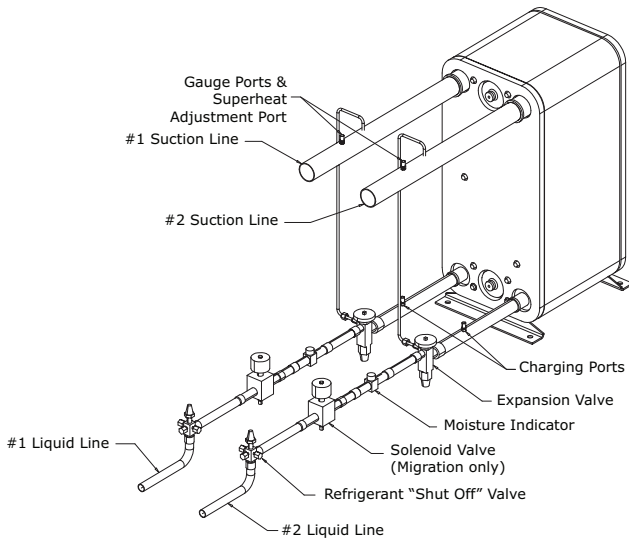
Figure 39. EVP chiller, typical refrigerant piping (2 circuit system)

Remote EVP Chiller

Water Treatment

NOTICE

Proper Water Treatment Required!

The use of untreated or improperly treated water could result in scaling, erosion, corrosion, algae or slime.

Use the services of a qualified water treatment specialist to determine what water treatment, if any, is required. Trane assumes no responsibility for equipment failures which result from untreated or improperly treated water, or saline or brackish water.

The use of untreated or improperly treated water could result in scaling, erosion, corrosion, and algae or slime buildup in the heat exchanger. This will adversely affect system capacity. Proper water treatment must be determined locally and depends on the type of system and local water characteristics. Neither salt nor brackish water is recommended, use of either will lead to a shortened heat exchanger life. Trane encourages employment of a qualified water treatment specialist, familiar with local water conditions, to assist in the establishment of a proper water treatment program.

Water Flow Limits

NOTICE

Heat Exchanger and Compressor Damage!

Water flow rates beyond the heat exchanger limits could result in permanent damage to the heat exchanger and/or compressor.

Do not operate outside recommended flow rates.

The minimum and maximum water flow rates are given in the General Data section. Water flow rates below the tabulated values will result in laminar flow causing freeze-up problems, scaling, stratification and poor system control. Flow rates exceeding the maximum listed could result in very high pressure drop, erosion of the heat exchanger and damage to the water flow switch.

Water Temperature Limits

NOTICE

Heat Exchanger and Compressor Damage!

Failure to follow instructions below could result in heat exchanger and compressor damage from water freezing in brazed plate and rupturing separation between refrigerant and water flow channels.

Leaving water temperatures below 42°F require glycol protection down to 15°F.

NOTICE

Evaporator Damage!

Circulating water temperatures above 125°F when the unit is not operating could result in evaporator damage.

Catalog chiller performance data is based on a water temperature drop of 10°F. Full load chilled water temperature drops from 8 to 14°F may be used as long as minimum and maximum water temperature and minimum and maximum flow rates are not violated. Leaving water temperatures below 42°F require freeze protection down to 15°F. The maximum water temperature that can be circulated through the chiller when the unit is not operating is 125°F. Evaporator damage could result above this temperature.

Short Water Loops

NOTICE

Compressor Damage!

Do not operate with water loops with less than five minutes circulation time as it could result in poor superheat control and compressor damage.

Adequate chilled water system water volume is an important system design parameter because it provides for stable chilled water temperature control and helps limit unacceptable short cycling of chiller compressors. Typically, a five-minute water loop circulation time is sufficient to prevent short water loop issues. Therefore, as a guideline, ensure the volume of water in the chilled water loop equals or exceeds five times the evaporator flow rate. For systems with a rapidly changing load profile the amount of volume should be increased.

Note: Water volumes should be calculated as close as possible to maintain constant water flow through the water loop.

Chiller accessory kit includes strainer, water flow switch, pipe stubs, couplings, evaporator insulation and mounting legs, and a ship separate braze plate heat exchanger.)

Chilled Water Piping

Typical Water Piping

Figure below illustrates typical water piping components for remote chiller applications. (Remote

Figure 40. EVP chiller – typical water piping

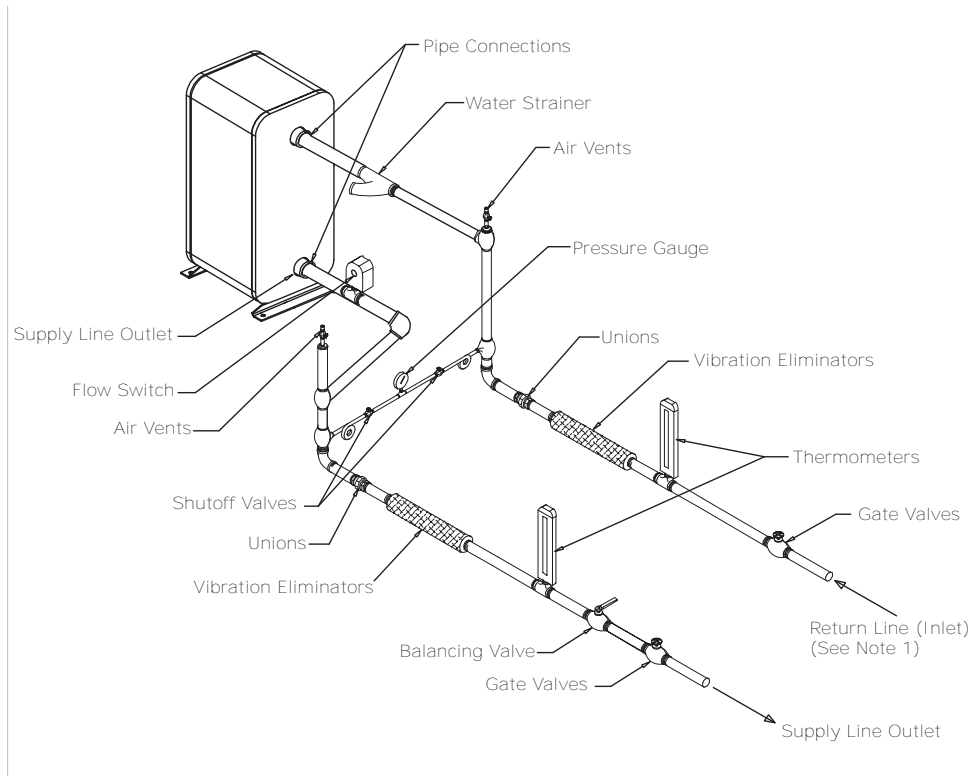

Notes:

- Shutoff valves are required for evaporator servicing.
- Evaporator is shown for illustration purposes only.
- Water inlet, outlet diameter dimensional locations depend on unit size.
- Water connections at the evaporator are grooved.
- Field supplied 1/2" x 14 NPTE stainless steel or PVC plug required.
- Locate freeze-stat and discharge temperature sensors close to the water outlet.
- Install drain with shutoff valve at low point in leaving piping before system valve.

Foreign matter in the chilled water system will increase pressure drop and reduce water flow. Installation of a properly selected strainer is also necessary to prevent debris larger than 0.039" from entering the heat exchanger. All building piping must be thoroughly flushed before making the final piping connections to the heat exchanger. The strainer must also be cleaned prior to initial start-up.

Important: Start up without flushing building piping risks plugging chiller with debris and reducing capacity.

To reduce heat loss and prevent condensation, insulation should be applied to piping. Expansion tanks are also usually required to accommodate chilled water volume changes.



Installation Mechanical – EVP

Braze Plate (BPHE) Chiller

Evaporator water inlet and outlet types, sizes and locations are shown in drawings in Dimensions and Weights chapter. Installation of a field provided 1/2" x 14 NPTE stainless steel or PVC plug is required.

Strainers should be installed as close as practical to the heat exchanger water inlet (the remote chiller accessory kit includes strainer and piping to connect with BPHE). A field provided blow down valve (recommended) or plug must be installed in strainer cleanout if not present.

Strainer

Install a strainer in the water supply line to protect the chiller from plugging with system piping debris.

Table 17. Chiller water pressure drop, Ft H2O

Flow (GPM)	Size, Tons								
	20	25	30	40	50	60	80	100	120
25	3.7								
30	5.2	3.2							
35	6.9	4.2							
40	8.8	5.4	3.1						
45	10.9	6.7	3.9						
50	13.3	8.2	4.8	5.3					
60	18.5	11.4	6.7	7.5	4.1				
70	24.6	15.2	8.9	10.1	5.5				
80		19.4	11.4	13.0	7.1	5.0			
90		24.1	14.2	16.3	8.9	6.3			
100			17.3	19.9	10.9	7.7	4.3		
120				28.3	15.4	10.9	6.1	3.2	
140					20.7	14.6	8.2	4.4	
160					26.7	18.9	10.6	5.6	4.8
180						23.6	13.2	7.1	6.1
200							16.2	8.7	7.4
240							22.9	12.3	10.6
280								16.5	14.2
320								21.3	18.3
360								26.7	23.0
400									28.2

Chilled Water Flow Switch

NOTICE

Evaporator Damage!

Failure to follow instructions could result evaporator damage.

To prevent evaporator damage, do not use water flow switch to cycle the system.

NOTICE

Heat Exchanger and Compressor Damage!

Water flow rates beyond the heat exchanger limits could result in permanent damage to the heat exchanger and/or compressor.

Do not operate outside recommended flow rates.

Figure 41. Optional flow switch

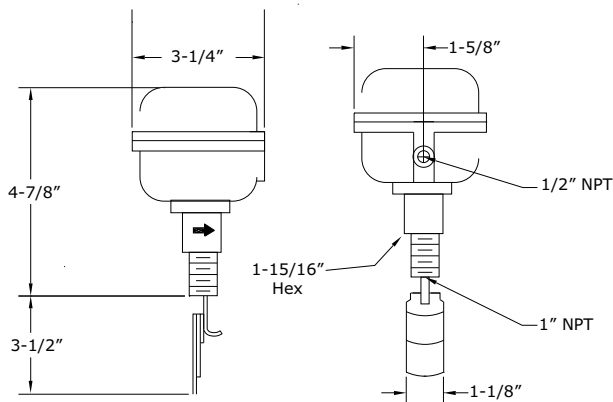

Install a flow switch or other flow sensing device to prevent or stop the compressor operation if the water flow drops below minimum limits. Locate the device in the chilled water return line as shown [Figure 40, p. 57](#). Install per switch manufacturer's instructions and refer to the field wiring and unit schematics for the flow switch electrical interlock connections. Adjust switch trip point to prevent operation below minimum limits.

The water flow switch included in the EVP chiller accessory kit must be adjusted to prevent flow below the minimum limit. To set the flow limit:

1. Establish minimum water flow.
2. Rotate the flow switch adjustment screw until the switch opens. This gets close to the correct setting but final adjustment must be done without water flow.
3. Beginning from water off, start flow and adjust GPM until the switch trips. If flow rate is below minimum, stop water flow and rotate adjusting screw accordingly.
4. Repeat until the switch trips at or above minimum flow.

Note: Use pressure gauge(s) and Water Pressure Drop table to determine water flow rate. See General Data for minimum flow limits.

Air Vents

Vents must be installed at high points in the piping system to facilitate air purging during the filling process. Air vents between the system shut off valve and heat exchanger are also useful for EVP chiller service and shutdown.

Water Pressure Gauges

NOTICE

Evaporator Damage!
Do not exceed 150 psig evaporator pressure as it could result in damage to the evaporator.

Install pressure gauge(s) to monitor the entering and leaving chilled water pressure, and strainer condition.

Water Shutoff Valves

Provide shutoff valves in the "Supply" and "Return" pipe near the chiller so the gauge(s), thermostats, sensors, strainer, etc., can be isolated during service.

Pipe Unions

Use pipe unions to simplify disassembly for system service. Use vibration eliminators to prevent transmitting vibrations through the water lines.

Thermometers

Install thermometers in the lines to monitor the evaporator entering and leaving water temperatures.

Balancing Valves

Install a balancing cock (valve) in the leaving water line. It will be used to establish a balanced flow.

Note: Both the entering and leaving water lines should have shutoff valves installed to isolate the evaporator for service.

Chiller Drain

Drain piping, with shut off valve, must be installed at the lowest point between the chiller and system piping valves to allow water removal for service and shut down procedures. The drain must be piped to a suitable facility.

Note: Insure that the drain is closed before filling system with water.

Water Temperature Sensor

The temperature sensor and sensor well must be installed in the leaving water piping as close to the chiller as possible. Both devices are located inside the remote panel. Thermal paste is also provided inside the remote panel and must be used when installing the sensor into the sensor-well.

NOTICE

Equipment Damage!
Failure to use thermal paste could result in erratic temperature sensing resulting in equipment damage.
Always use thermal paste on temperature sensor installation.

Figure below illustrates the sensor well dimensions.

Figure 42. Freezestat bulbwell, temperature sensor and well

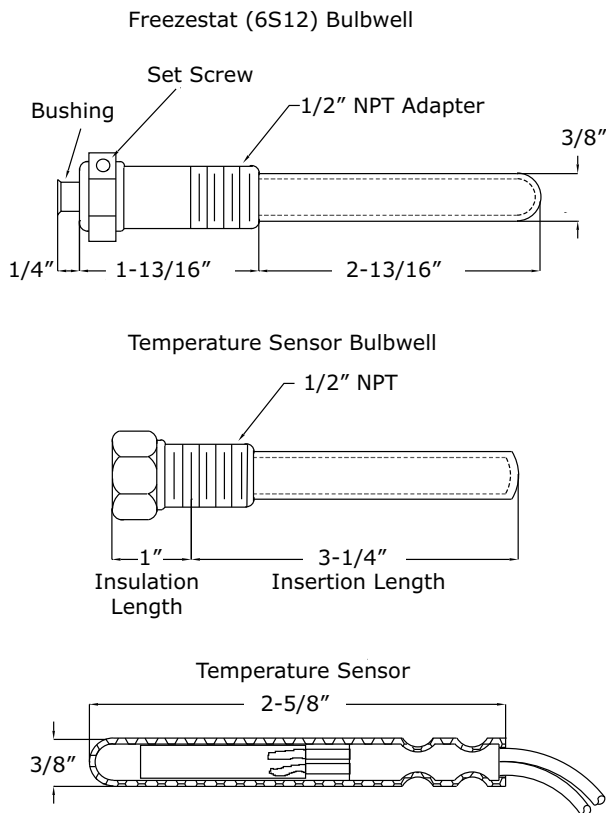

Freezestat

A bulbwell (located inside the remote panel) must be installed in the leaving water piping as close to the

chiller as possible. It should be located upstream of the temperature sensor location. The freezestat, located within the remote panel, is equipped with a remote sensing bulb and 20 feet of capillary tube. The remote sensing bulb must be installed by the installing personnel. Thermal paste is also provided inside the remote panel and must be used when installing the bulb into the bulb-well. Figure above illustrates the bulbwell dimensions.

Important: Isolate the water pumps from the system piping to avoid vibration transmission. Insulate all water piping. Use appropriate pipe sealant on all threaded connections.

Final Water Piping Connections

1. Flush all water piping in the system thoroughly before making the final connections.

NOTICE

Heat Exchanger Damage!

Failure to follow instructions below could result in heat exchanger damage.

If an acidic commercial flushing solution is used, bypass the EVP chiller to prevent damage .

2. Clean strainer.
3. Connect the water pipe to the EVP chiller.
4. Make sure the 1/2" x 14 NPTE plug is installed.
5. Close the drain shutoff valve.
6. While filling the chiller system with solution, vent the air from the system at the highest points.



Installation Electrical

Electrical

Note: Local codes may take precedence.

Table 18. RAUJ electrical data

Unit Size (ton)	Rated Voltage ^(a)	Condenser Fan Motor ^(b)		CPT Amps	Compressor Motor ^(b)								Unit Characteristics	
		Qty	FLA		RLA		1C/2C		LRA		MCA ^(c)	MOP ^(d)		
					1A/2A	1B/2B	1A/2A	1B/2B	1A/2A	1B/2B			1C/2C	1C/2C
20	200/60/3XL	2	4.1	1	41.4	41.4	-	267	267	-	267	267	102	125
	230/60/3XL	2	4.1	1	35.5	35.5	-	267	267	-	267	267	89	110
	460/60/3XL	2	1.8	1	18.6	18.6	-	142	142	-	142	142	45	60
	575/60/3XL	2	1.4	1	15.8	15.8	-	103	103	-	103	103	38	50
	380/415/50/3XL	2	1.7	1	18.6	18.6	-	142	142	-	142	142	46	60
25	200/60/3XL	3	4.1	1	41.4	52	-	267	267	-	267	315	120	150
	230/60/3XL	3	4.1	1	35.5	46.9	-	267	267	-	267	315	108	150
	460/60/3XL	3	1.8	1	18.6	22.2	-	142	142	-	142	158	52	70
	575/60/3XL	3	1.4	1	15.8	19.2	-	103	103	-	103	136	45	60
	380/415/50/3XL	3	1.7	1	18.6	22.2	-	142	142	-	142	158	52	70
30	200/60/3XL	3	4.1	1	56.9	56.9	-	351	351	-	351	351	141	175
	230/60/3XL	3	4.1	1	48.8	48.8	-	351	351	-	351	351	123	150
	460/60/3XL	3	1.8	1	25.5	25.5	-	197	197	-	197	197	63	80
	575/60/3XL	3	1.4	1	23.1	23.1	-	146	146	-	146	146	56	70
	380/415/50/3XL	3	1.7	1	25.5	25.5	-	197	197	-	197	197	63	80
40	200/60/3XL	4	4.1	3	41.4	41.4	-	267	267	-	267	267	195	225
	230/60/3XL	4	4.1	2	35.5	35.5	-	267	267	-	267	267	169	200
	460/60/3XL	4	1.8	1	18.6	18.6	-	142	142	-	142	142	87	100
	575/60/3XL	4	1.4	1	15.8	15.8	-	103	103	-	103	103	73	80
	380/415/50/3XL	4	1.7	1	18.6	18.6	-	142	142	-	142	142	86	100
50	200/60/3XL	6	4.1	3	47	52	-	304	304	-	304	315	238	250
	230/60/3XL	6	4.1	2	42.3	46.9	-	304	304	-	304	315	217	250
	460/60/3XL	6	1.8	1	20.2	22.2	-	147	147	-	147	158	102	110
	575/60/3XL	6	1.4	1	17.1	19.2	-	122	122	-	122	136	86	100
	380/415/50/3XL	6	1.7	1	20.2	22.2	-	147	147	-	147	158	101	110

Table 18. RAUJ electrical data (continued)

Unit Size (ton)	Rated Voltage ^(a)	Condenser Fan Motor ^(b)		CPT Amps	Compressor Motor ^(b)								Unit Characteristics	
		Qty	FLA		RLA		1A/2A		1B/2B		1C/2C		MCA ^(c)	MOP ^(d)
					Qty	Amps	1A/2A	1B/2B	1C/2C	1A/2A	1B/2B	1C/2C		
60	200/60/3XL	6	4.1	3	4	56.9	56.9	-	351	351	-	269	300	
	230/60/3XL	6	4.1	2	4	48.8	48.8	-	351	351	-	234	250	
	460/60/3XL	6	1.8	1	4	25.5	25.5	-	197	197	-	120	125	
	575/60/3XL	6	1.4	1	4	23.1	23.1	-	146	146	-	107	125	
	380/415/50/3XL	6	1.7	1	4	25.4	25.4	-	197	197	-	119	125	
80	200/60/3XL	8	4.1	4	6	60.5	60.5	60.5	320	320	320	415	450	
	230/60/3XL	8	4.1	3	6	52	52	52	320	320	320	361	400	
	460/60/3XL	8	1.8	2	6	25.4	25.4	25.4	160	160	160	175	200	
	575/60/3XL	8	1.4	1	6	20.3	20.3	20.3	135	135	135	139	150	
100	200/60/3XL	12	4.1	4	6	60.5	60.5	83.9	320	320	485	484	500	
	230/60/3XL	12	4.1	3	6	52	52	74.5	320	320	485	428	500	
	460/60/3XL	12	1.8	2	6	25.4	25.4	37.2	160	160	215	209	225	
	575/60/3XL	12	1.4	1	6	20.3	20.3	29.8	135	135	175	166	175	
120	200/60/3XL	12	4.1	4	6	83.9	83.9	83.9	485	485	485	578	600	
	230/60/3XL	12	4.1	3	6	74.5	74.5	74.5	485	485	485	518	600	
	460/60/3XL	12	1.8	2	6	37.2	37.2	37.2	215	215	215	256	300	
	575/60/3XL	12	1.4	1	6	29.8	29.8	29.8	175	175	175	205	225	

^(a) Voltage Utilization Range is +/- 10% of Rated voltage (use range): 200/60/3 (180-220), 230/60/3 (208-254), 460/60/3 (414-506), 575/60/3 (516-633), 380/50/3 (342-418), 415/50/3 (373-456)

^(b) Electrical information is for each individual motor.

^(c) Minimum circuit ampacity (MCA) is 125 percent of the RLA of one compressor motor plus the total RLA of the remaining motors.

^(d) Maximum Overcurrent Protection Device permitted by NEC 440-22 is 225 percent of the RLA of one compressor motor plus the total RLA of the remaining motors.

Wiring Requirements

Main Electrical Power Requirements

⚠ WARNING

Proper Field Wiring and Grounding Required!

Failure to follow code could result in death or serious injury.

All field wiring **MUST** be performed by qualified personnel. Improperly installed and grounded field wiring poses **FIRE** and **ELECTROCUTION** hazards. To avoid these hazards, you **MUST** follow requirements for field wiring installation and grounding as described in NEC and your local/state/national electrical codes.

- Verify the power supply meets the required power requirements of the system.
- Install power wiring in accordance with all applicable codes.
- Install and connect properly sized power supply wiring, with over current protection, to the main power terminal block (1TB1) or to an optional factory mounted non-fused disconnect switch (1S1) in the control panel.
- Install and connect properly sized power supply wiring, with over current protection, to the proper termination point in the air handling unit (if applicable).
- Install proper grounding wires to an earth ground.
- For EVP units only, install and connect properly sized power supply wiring, with overcurrent protection, to the proper termination point for the chilled solution pump.

Field Installed Control Wiring Requirements

⚠ WARNING

Hazardous Voltage!

Failure to disconnect power before servicing could result in death or serious injury.

Disconnect all electric power, including remote disconnects before servicing. Follow proper lockout/tagout procedures to ensure the power can not be inadvertently energized. Verify that no power is present with a voltmeter.

⚠ WARNING

Proper Field Wiring and Grounding Required!

Failure to follow code could result in death or serious injury.

All field wiring **MUST** be performed by qualified personnel. Improperly installed and grounded field wiring poses **FIRE** and **ELECTROCUTION** hazards. To avoid these hazards, you **MUST** follow requirements for field wiring installation and grounding as described in NEC and your local/state/national electrical codes.

115 Volt Control Wiring (All Units)

- Verify that the Control transformer (1T1) is wired for the proper operating voltage.
- Connect properly sized wiring to the liquid line solenoid valve(s).
- The phase monitor (1U3) when powered with line voltage properly phased and balanced has a green LED energized.
- Connect properly sized wiring to the hot gas bypass solenoid valve(s), if applicable, to operate with the unit. Refer to the unit wiring diagram that shipped with the unit.
- Install the interlock circuitry wiring for the air handling unit to permit compressor operation after the fan has started, i.e., proof of fan operation device, fan starter auxiliary contacts or pump starter station, pump starter auxiliary contacts, proof of flow device, etc. Refer to the field connection diagram that shipped with the unit for interlocking information.
- Install properly sized power supply wiring, with over current protection, to the proper termination point for the field provided economizer actuator(s), if applicable. Refer to the "Economizer Actuator Circuit" illustrated in the "Field Installed Control Wiring" section.

"No Controls" Units

- A field provided "step" controller must be installed and properly wired. (Controller will have 2, 4 or 6 steps, depending on unit configuration.) Refer to the field connection diagram for connection information.
- Install proper grounding wires to an earth ground.
- Install an outside air thermostat in series with the flow switch to stop or prevent the unit from operating below the recommended ambient temperatures.

EVP Chiller Units

- Install proper grounding wires to an earth ground.



Installation Electrical

- Install an outside air thermostat in series with the flow switch to stop or prevent the unit from operating below the recommended ambient temperatures.

Low Voltage Wiring (AC & DC)

⚠ WARNING

Hazardous Voltage!

Failure to disconnect power before servicing could result in death or serious injury.

Disconnect all electric power, including remote disconnects before servicing. Follow proper lockout/tagout procedures to ensure the power can not be inadvertently energized. Verify that no power is present with a voltmeter.

⚠ WARNING

Proper Field Wiring and Grounding Required!

Failure to follow code could result in death or serious injury.

All field wiring **MUST** be performed by qualified personnel. Improperly installed and grounded field wiring poses **FIRE** and **ELECTROCUTION** hazards. To avoid these hazards, you **MUST** follow requirements for field wiring installation and grounding as described in NEC and your local/state/national electrical codes.

Variable Air Volume (VAV) Units

- Install a field provided remote system control switch to activate the system.
- Connect properly sized wiring from the field provided economizer, if applicable, to the discharge air controller in the unit control panel.
- Install and connect properly sized wiring from the night setback relay contacts to the proper termination points inside the unit control panel. Verify the appropriate jumpers have been removed.
- Install the suction line thermostat onto the suction line. Connect properly sized wiring between the thermostat and terminal strip 7TB7 in the unit control panel.
- Install the discharge air sensor and wire it to the discharge air controller with shielded cable.

Constant Volume Units

- Install the zone thermostat, with or without switching subbase.
- Connect properly sized control wiring to the proper termination points between the zone thermostat and the unit control panel.
- Install the discharge air sensor and connect it to the master energy controller (MEC) with shielded cable.

- Connect properly sized wiring from the field provided economizer, if applicable, to the master energy controller (MEC) in the unit control panel.

EVP Chillers

- Install the appropriate jumpers on the chilled water temperature controller for hot gas bypass operation (if applicable). Refer to the control wiring diagram that shipped with the unit for jumper details.
- Install and connect the chilled water temperature sensor to the chilled solution temperature controller with shielded cable.
- Install the proper staging resistor on to the chilled water temperature controller.

Field Installed Power Wiring

⚠ WARNING

Proper Field Wiring and Grounding Required!

Failure to follow code could result in death or serious injury.

All field wiring **MUST** be performed by qualified personnel. Improperly installed and grounded field wiring poses **FIRE** and **ELECTROCUTION** hazards. To avoid these hazards, you **MUST** follow requirements for field wiring installation and grounding as described in NEC and your local/state/national electrical codes.

NOTICE

Use Copper Conductors Only!

Failure to use copper conductors could result in equipment damage as the equipment was not designed or qualified to accept other types of conductors.

See Dimensions and Weights chapter for overall dimensional layouts for the field installed wiring locations. To insure that the unit's supply power wiring is properly sized and installed, follow the guidelines outlined below.

Note: All field installed wiring must conform to NEC guidelines as well as state and local codes.

Verify that the power supply available is compatible with the unit's nameplate ratings. The available supply power must be within 10% of the rated voltage stamped on the nameplate.

Disconnect Switch External Handle (Factory Mounted Option)

Figure 43. Disconnect switch details

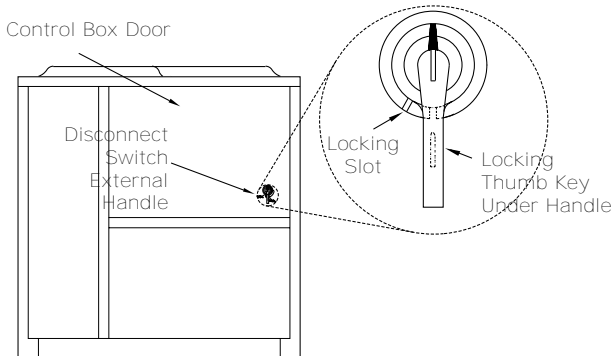

Units ordered with the factory mounted nonfused disconnect switch comes equipped with an externally mounted handle. This allows the operator to disconnect power from the unit without having to open the control panel door. Handle locations and its three positions are shown below:

- “ON” - Indicates disconnect switch is closed, allowing main power supply to be applied at unit.
- “OFF” - Indicates disconnect switch is open, interrupting main power supply to unit controls.
- “OPEN COVER/RESET” - Turning the handle to this position releases the handle from the disconnect switch, allowing the control panel door to be opened.

Once the door has been opened, it can be closed with the handle in any one of the three positions outlined above, provided it matches the disconnect switch position.

The handle can be locked in the “OFF” position. While holding the handle in the “OFF” position, push the spring loaded thumb key, attached to the handle, into the base slot. Place the lock shackle between the handle and the thumb key. This will prevent it from springing out of position.

Main Unit Power Wiring

⚠ WARNING

Hazardous Voltage!

Failure to disconnect power before servicing could result in death or serious injury.

Disconnect all electric power, including remote disconnects before servicing. Follow proper lockout/tagout procedures to ensure the power can not be inadvertently energized. Verify that no power is present with a voltmeter.

⚠ WARNING

Proper Field Wiring and Grounding Required!

Failure to follow code could result in death or serious injury.

All field wiring MUST be performed by qualified personnel. Improperly installed and grounded field wiring poses FIRE and ELECTROCUTION hazards. To avoid these hazards, you MUST follow requirements for field wiring installation and grounding as described in NEC and your local/state/national electrical codes.

NOTICE

Use Copper Conductors Only!

Failure to use copper conductors could result in equipment damage as the equipment was not designed or qualified to accept other types of conductors.

See “Power Wire Sizing and Protection Devices,” p. 66 for field connection wire ranges for main power terminal block 1TB1 and optional disconnect switch 1S1.

See Electrical Data tables for unit electrical data. The electrical service must be protected from over current and short circuit conditions in accordance with NEC requirements. Protection devices must be sized according to the electrical data on the nameplate.

- See Calculation — MCA, MOP, and RDE in “Wiring Requirements,” p. 63 section to determine the following:
 - Electrical service wire size based on Minimum Circuit Ampacity (MCA),
 - Maximum Overcurrent Protection (MOP) device.
 - Recommended Dual Element fuse size (RDE).
- If the unit is not equipped with an optional factory installed non-fused disconnect switch, a field supplied disconnect switch must be installed at or near the unit in accordance with the National Electrical Code (latest edition). See Calculation — Disconnect Switch Sizing (DSS) in “Wiring Requirements,” p. 63 section to determine the correct size.
- Complete the unit’s power wiring connections onto either the main terminal block 1TB1, or the factory mounted non-fused disconnect switch 1S1, inside the unit control panel. Refer to the customer connection diagram that shipped with the unit for specific termination points.
- Provide proper grounding for the unit in accordance with local and national codes.



Installation Electrical

Power Wire Sizing and Protection Devices

Table 19. RAUJ power wire selections

Unit Size (tons)	Voltage	To Disconnect Switch (1S1)		To Main Terminal Block	
		Disconnect Size (amps)	Connector Wire Range	Terminal Block Size (amps)	Connector Wire Range
20, 30, 40	200/230	250	(1) #4-350 kcmil	335	(1) #6-350 MCM
	380/415/460	100	(1) #14-1/0	335	(1) #6-350 MCM
	575	100	(1) #14-1/0	335	(1) #6-350 MCM
50	200/230	400	(1) #1 - 600 kcmil OR(2) #1 - 250 kcmil	335	(1) #6-350 MCM
	380/415/460	250	(1) #4-350 kcmil	335	(1) #6-350 MCM
	575	100	(1) #14-1/0	335	(1) #6-350 MCM
60	200/230	400	(1) #1 - 600 kcmil OR(2) #1 - 250 kcmil	335	(1) #6-350 MCM
	380/415/460	250	(1) #4-350 kcmil	335	(1) #6-350 MCM
	575	250	(1) #4-350 kcmil	335	(1) #6-350 MCM
80 to 120	All	-	-	760	(2) #4-500 MCM

Table 20. Control wire selections

Units Sizes (tons)	Wire Gauge	Ohms per 1000 feet	Max Wire Length (ft)
All	18	8	500
All	16	5	1000
All	14	3	2000
80 to 120	12	2	3000

Table 21. Control terminal blocks

Unit Size	Control Terminal Blocks
20 to 60	7TB5 thru 7TB8, 6TB9
80 to 120	7TB5 thru 7TB8

Equations

To correctly size main power wiring for the unit, use appropriate calculation(s) listed below.

Load Definitions for Calculations

- LOAD 1: Current of largest motor (compr or fan motor)
- LOAD 2: Sum of the currents of all remaining motors
- LOAD 4: Control panel transformer and any other load rated at 1A or more

Calculation – MCA, MOP, and RDE

- MCA = (1.25 x LOAD 1) + LOAD 2 + LOAD 4
- MOP = (2.25 x LOAD 1) + LOAD 2 + LOAD 4

Select a fuse rating equal to the MOP value. If the MOP value does not equal a standard fuse size as listed in NEC 240 - 6, select the next lower standard fuse rating.

Note: If selected MOP is less than the MCA, then select the lowest standard maximum fuse size which is equal to or larger than the MCA, provided the selected fuse size does not exceed 800 amps.

- RDE = (1.5 x LOAD 1) + LOAD 2 + LOAD 4

Select a fuse rating equal to the RDE value. If the RDE value does not equal a standard fuse size as listed in NEC 240 - 6 select the next higher standard fuse rating.

Note: If the selected RDE is greater than selected MOP value, select RDE value to equal MOP value.

Calculation – Disconnect Switch Sizing (DSS)

- DSS = 1.15 X (LOAD 1 + LOAD 2 + LOAD 4)

Field Installed Control Wiring

⚠ WARNING

Hazardous Voltage!

Failure to disconnect power before servicing could result in death or serious injury.

Disconnect all electric power, including remote disconnects before servicing. Follow proper lockout/tagout procedures to ensure the power can not be inadvertently energized. Verify that no power is present with a voltmeter.

⚠ WARNING

Proper Field Wiring and Grounding Required!

Failure to follow code could result in death or serious injury.

All field wiring **MUST** be performed by qualified personnel. Improperly installed and grounded field wiring poses **FIRE** and **ELECTROCUTION** hazards. To avoid these hazards, you **MUST** follow requirements for field wiring installation and grounding as described in NEC and your local/state/national electrical codes.

Before installing any connecting wiring, see drawings Dimensions and Weights chapter for the electrical access locations provided on the unit. Install appropriately sized control wiring for the 115 volt electrical components as required by the application.

Since the unit-mounted 115V control power transformer (1T1) is provided on all units, it is not necessary to run a separate 115 volt control power source to the unit.

Note: All 200/230V units are shipped with transformer 1T1 wired for 200 volt operation. If the unit is to be operated on a 230V power supply, rewire the transformer as shown on the unit schematic.

Note: All field wiring must conform to NEC guidelines as well as state and local codes.

Controls Wiring – 115 VAC

⚠ WARNING

Hazardous Voltage!

Failure to disconnect power before servicing could result in death or serious injury.

Disconnect all electric power, including remote disconnects before servicing. Follow proper lockout/tagout procedures to ensure the power can not be inadvertently energized. Verify that no power is present with a voltmeter.

Install appropriately sized 115 volt control wiring for the electrical components as required by the application.

These components may include:

- Hot gas bypass solenoid wiring
- Supply fan interlock and control circuit
- System control switch wiring (“No Control” units)
- Step controller wiring (“No Control” units)
- Chilled water pump interlock wiring (EVP units)
- Chilled water flow switch wiring (EVP units)
- Outside air thermostat wiring (EVP units)
- Liquid line solenoid valve(s)

Supply Fan Interlock

Control Options Utilizing an Air Handler

The normally open evaporator fan interlock auxiliary contacts and the evaporator fan controls; system On/Off switch, fan starter/contactor, and overloads, must be wired as illustrated in the appropriate interlock connection wiring diagram for the specified application.

EVP Flow control (6S58)

The flow switch is a binary output device and must be wired within the interlock circuit. Before installing the control wiring, refer to the remote panel illustration for the electrical access into the panel. Refer to the field connection diagram for the specific connection points inside the remote panel.

EVP Circulating Pump Interlock

Pump operation and sequence is the responsibility of the installer. During compressor operation, the fluid flow through the chiller must be maintained. The field provided; ON/OFF switch, pump starter/contactor, auxiliary contacts and overloads (OLs) must be installed as part of the system’s interlock circuit to disable the compressors in the event the circulating pump shuts down or is turned off.

Note: Due to the location of the 5S1 switch within the circulating pump control circuit, it can be used as a system ON/OFF switch.

Outside Air Thermostat (5S57)

A field provided outside air thermostat must be installed within the interlock circuit to prevent the system from operating below its workable temperature range. Before installing the control wiring, refer to the remote panel illustration for the electrical access into the panel. Refer to the field connection diagram for the specific connection points inside the remote panel. Refer to the “EVP Chiller Controls” section for temperature requirements.

Hot Gas Bypass (All control options)

If hot gas bypass is required, refer to the “Refrigerant Piping” illustration for supporting equipment tubing connections. Refer to the specific control option field connection diagram terminal connections for the hot gas bypass solenoid coils.

Controls Wiring – 24 VAC

⚠ WARNING

Hazardous Voltage!

Failure to disconnect power before servicing could result in death or serious injury.

Disconnect all electric power, including remote disconnects before servicing. Follow proper lockout/tagout procedures to ensure the power can not be inadvertently energized. Verify that no power is present with a voltmeter.

NOTICE

Component Failure!

Resistance in excess of 3 ohms per conductor could result in component failure due to insufficient AC voltage supply. Do not exceed three (3) ohms per conductor for the length of the run.

Before installing any connecting wiring, see drawings in the Dimensions and Weights chapter for the electrical access locations provided on the unit and table below for AC conductor sizing guidelines, and;

- Use copper conductors unless otherwise specified.
- Ensure that the AC control wiring between the controls and the unit's termination point does not exceed three (3) ohms/conductor for the length of the run.
- Be sure to check all loads and conductors for grounds, shorts, and miswires.
- Do not run the AC low voltage wiring in the same conduit with the high voltage power wiring.

Typical Low voltage components may include:

- Zone thermostat wiring (AC & DC wiring)
- System control switch wiring (VAV units)
- Night setback relay wiring (VAV units)
- Economizer actuator circuit wiring (VAV units)
- Discharge air sensor wiring (VAV units)
- Jumpers for hot gas bypass operation
- Chilled water temperature sensor (EVP units)

Table 22. AC conductors

Distance from Unit to Control	Recommended Wire Size
000 - 460 feet	18 gauge
461 - 732 feet	16 gauge
733 - 1000 feet	14 gauge

Controls – DC Analog Input/Outputs

⚠ WARNING

Hazardous Voltage!

Failure to disconnect power before servicing could result in death or serious injury.

Disconnect all electric power, including remote disconnects before servicing. Follow proper lockout/tagout procedures to ensure the power can not be inadvertently energized. Verify that no power is present with a voltmeter.

Before installing any connecting wiring between the unit and components utilizing a DC analog input/output, see drawings in Dimensions and Weights

chapter for the electrical access locations provided on the unit.

Table 23. Components

Unit Size (tons)	Component ^(a)	Designation	Unit Type
20 to 60	Field installed Discharge Duct Sensor	6RT1	CV
	Field installed Return Duct Sensor	6RT6	CV
	Field installed Discharge Air Sensor	6RT3	VAV
	Field installed Chilled Water Sensor	6RT2	EVP
80 to 120	Field installed Discharge Air Sensor	8RT3	VAV
	Field installed Chilled Water Sensor	8RT2	EVP

^(a) Units may include the listed components. Not all components will be selected on all units.

- Wiring for the components utilizing a DC analog input/output signal must be shielded cable (Belden 8760 or equivalent). Ground the shield at one end only.
- Table below lists the conductor sizing guidelines that must be followed when interconnecting a DC binary output device to the unit.

Note: Resistance in excess of 2.5 ohms per conductor can cause deviations in the accuracy of the controls.

- Ensure that the wiring between the binary controls and the unit's termination point does not exceed two and a half (2.5) ohms/conductor for the length of the run.
- Do not run the electrical wires transporting DC signals in or around conduit housing high voltage wires.

Table 24. DC conductors

Distance from Unit to Control	Recommended Wire Size
000 - 499 feet	16 gauge
500 - 1000 feet	14 gauge

Economizer Actuator Circuit

Each unit ordered with the Constant Volume or Variable Air Volume control option has the capability of controlling a field installed economizer. The diagram below illustrates a typical economizer actuator circuit.

When connecting the economizer actuator control circuit to the terminal board inside the unit control

panel, refer to the actual unit wiring diagram for terminal designation, i.e. W, B, R, & Y. A separate

power supply for the actuator(s) must be field provided.

Figure 44. Unit control panel – 20 to 60 tons

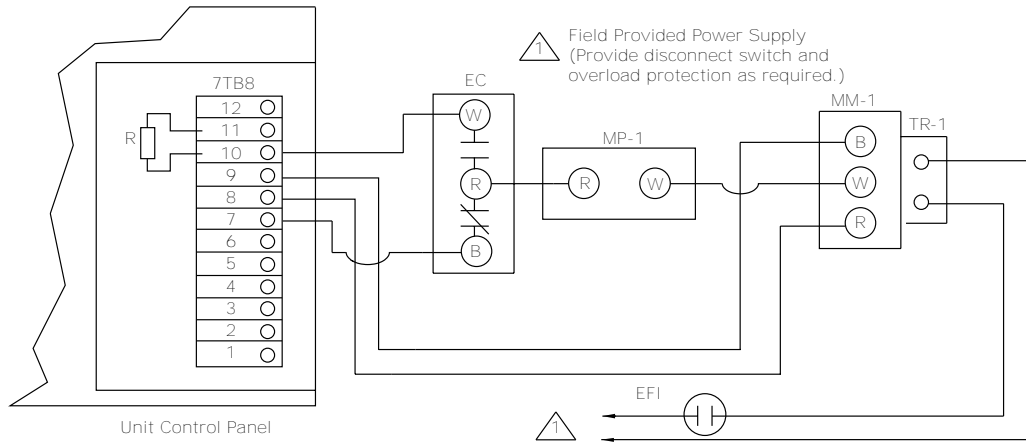

Figure 45. Unit control panel – 80 to 120 tons

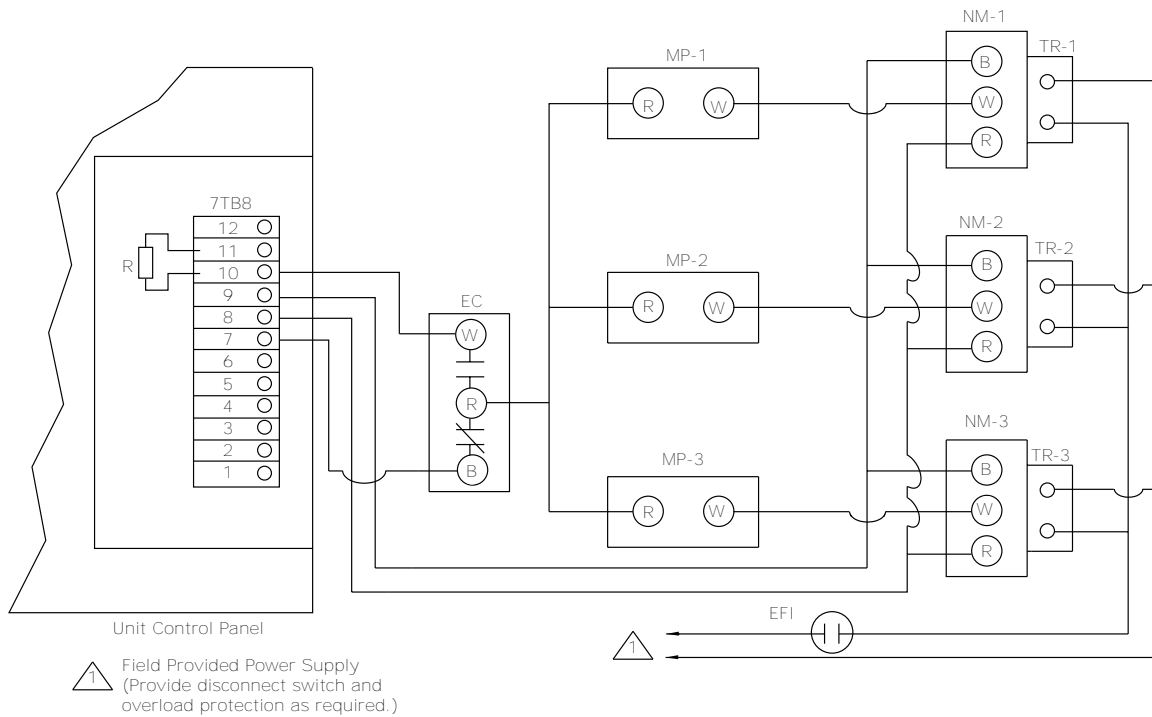

Table 25. Economizer actuator circuit legend

Device Designation	Device Designation	Parts And Notes
MM	Modutrol Motor	M.H. M955 (Up to 3 motors may be controlled as shown. Additional motors must be slaved.)
TR	Transformer	M.H. 13081B; cover mounted
EC	Enthalpy Control	M.H. H2051046



Installation Electrical

Table 25. Economizer actuator circuit legend (continued)

Device Designation	Device Designation	Parts And Notes
MP	Minimum Position Potentiometer	M.H. S96A1012
EFI	Evaporator Fan Interlock	Field Provided
7TB88	Low Voltage Terminal Strip	Located in Temperature Controller Panel
R	1/4 Watt - 5% Carbon	1 Motor/Circuit = None Req; 2 Motors/ circuit = 1300 Ohms; 3 Motors/Circuit = 910 Ohms

No System Control

Temperature Control Parameters

⚠ WARNING

Hazardous Voltage!

Failure to disconnect power before servicing could result in death or serious injury.

Disconnect all electric power, including remote disconnects before servicing. Follow proper lockout/tagout procedures to ensure the power can not be inadvertently energized. Verify that no power is present with a voltmeter.

Each unit ordered with the "No Controls" option, requires a field provided and field wired temperature

controller. Single refrigerant circuit units require a 2-step control device, and dual refrigerant circuit units require a 4-step (20 to 60 ton units) or 6-step (80-120 ton units) control device.

Each unit is shipped from the factory with internal "Fixed-On" & "Fixed-Off" time delays wired into each step of cooling. The "Fixed-Off" timers are 5 minutes each and they begin timing when the circuit for that step of cooling is deactivated. The "Fixed-On" timers are 3 minutes each and they begin timing when the circuit for that step is activated.

Note: Units ordered with the "No Controls" option cannot be used with EVP Chiller applications.

Figure 46. Field connection diagram RAUJ 20 to 60 tons — no system control

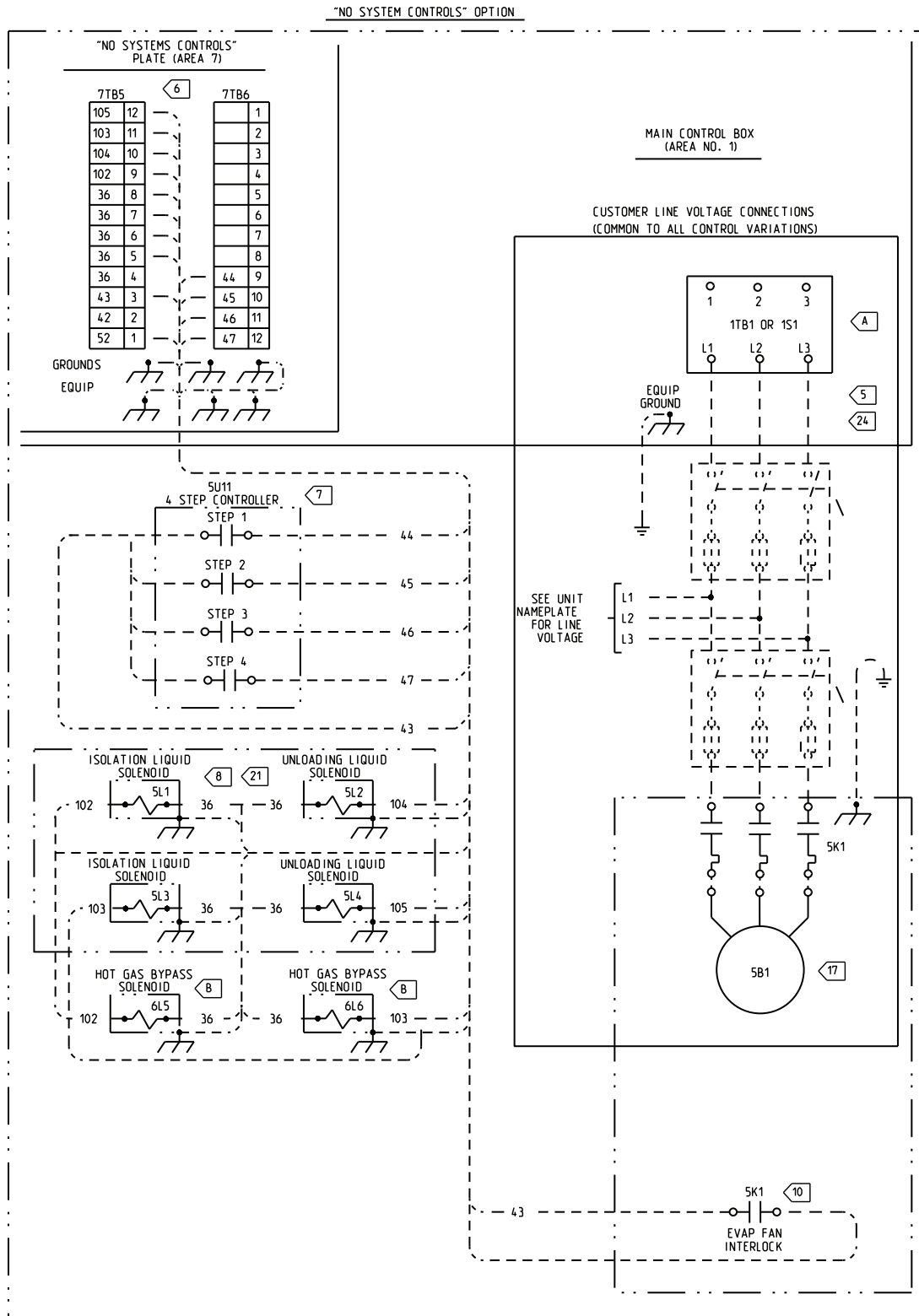

2307-9122



Installation Electrical

Figure 47. Field connection diagram RAUJ 20 to 60 tons — all system controls

NOTE:

1. ALL WIRING AND COMPONENTS SHOWN DASHED TO BE SUPPLIED AND INSTALLED BY CUSTOMER IN ACCORDANCE WITH LOCAL AND NATIONAL ELECTRICAL CODES.
2. ALL WIRING TO BE N.E.C. CLASS 1 UNLESS OTHERWISE SPECIFIED.
3. CAUTION -- DO NOT ENERGIZE UNIT UNTIL CHECK-OUT AND START-UP PROCEDURES HAVE BEEN COMPLETED.
4. ALL THREE PHASE MOTORS ARE PROTECTED UNDER PRIMARY SINGLE PHASE FAILURE CONDITIONS.
5. SEE TABLE OF ACCEPTABLE WIRE SIZES FOR CONNECTION TO MAIN UNIT TERMINAL BLOCK (1TB1) OR DISCONNECT SWITCH (1S1).
6. SIZE CONTROL WIRING SUCH THAT TOTAL WIRE RESISTANCE OF THE RUN DOES NOT EXCEED 6 OHMS. SEE TABLE FOR WIRE SELECTION.
7. 4 STEP CONTROLLER (5U11) MIN. RATING - N.O. CONTACTS = 150 VA INRUSH/75 VA SEALED; N.C. CONTACTS = 80 VA INRUSH/40 VA SEALED.
8. ISOLATION LIQUID SOLENOID VALVES (5L1,5L3), UNLOADING LIQUID SOLENOID VALVES (5L2,5L4) AND HOT GAS BYPASS SOLENOID VALVES (6L5,6L6) -- MAX. SOLENOID RATINGS ARE 72 VA INRUSH/30 VA SEALED.
9. CIRCULATING PUMP CONTROL CIRCUIT MAX. RATINGS ARE 240 VA INRUSH/40 VA SEALED.
10. STARTER INTERLOCK (5K1), OUTSIDE AIR T-STAT (5S57), SYSTEM ON/OFF SWITCH (5S1), STARTER OVERLOAD RELAY (5K1 OL) AND FLOW SWITCH (6S58) MIN. RATINGS ARE 250 VA INRUSH/125 VA SEALED.
12. REMOVE RESISTOR (7R5 - 7TB8-4 & 5) WHEN FIELD SUPPLIED ECONOMIZER IS REQUIRED WITH OPTIONAL VARIABLE AIR VOLUME ("VAV") CONTROLS.
13. WIRING FOR DUCT SENSOR (6RT1), CHILLER TEMP SENSOR (6RT2), DISCHARGE AIR SENSOR (6RT3) AND RETURN AIR SENSOR (6RT6) MUST BE SHIELDED CABLE AND NOT RUN IN CONDUIT WITH OTHER WIRING. FOR RUNS UNDER 500 FEET USE 16 GA (MIN) WIRE. FOR RUNS FROM 500 TO 1000 FEET USE 14 GA (MIN) WIRE. MAXIMUM RUN IS 1000 FEET. GROUND SHIELD AT ONE END ONLY.
14. SUGGESTED SYSTEM CONTROL SWITCH (5S2) FOR "VAV" CONTROLS OPTION IS CUTLER HAMMER 7580K5 SPST TOGGLE SWITCH OR EQUIVALENT.
15. WHEN NIGHT SETBACK IS REQUIRED WITH OPTIONAL "VAV", PROVIDE A CONTACT CLOSURE SUITABLE FOR A DRY CIRCUIT WITH MIN. RATING OF 125 VA/24 VAC - PILOT DUTY. REMOVE JUMPER (7TB7-4 & 5) WHEN REQUIRED.
16. OUTSIDE AIR T-STAT (5S57) IS REQUIRED ONLY WITH "EVP" OPTION - FOR LOW AMBIENT COMPRESSOR LOCKOUT.
17. CIRCUIT AS SHOWN IS FOR A CUSTOMER SUPPLIED EVAPORATOR FAN MOTOR (5B1) AND EVAP FAN STARTER (5K1). WHEN "EVP" OPTION IS REQUIRED, THIS CIRCUIT BECOMES A CIRCULATING PUMP MOTOR (5B1) AND A CIRCULATING PUMP STARTER (5K1).
18. INSTALL JUMPER (6TB9-7 & 8) WHEN HOT GAS BYPASS OPTION IS REQUIRED WITH OPTIONAL "EVP". INSTALL HOT GAS BYPASS SOLENOID VALVE (6L5) AS SHOWN.
19. WHEN DUCT SENSOR (6RT1) IS REQUIRED, REMOVE RESISTOR (7R1 FROM 7TB8-5 & 6).
20. CUSTOMER SUPPLIED HEATER CONTACTOR CONTROL CIRCUIT -
120V/240V/1PH MAX RATING = 750VA INRUSH, 75VA SEALED;
24V/1PH MAX RATING = 240VA INRUSH, 60VA SEALED.
21. ISOLATION LIQUID SOLENOID VALVES (5L1,5L3) ARE REQUIRED FOR CHARGE ISOLATION (PROVIDED & INSTALLED BY THE FIELD). UNLOADING LIQUID SOLENOID VALVES (5L2,5L4), IF APPLICABLE, ARE PROVIDED & INSTALLED BY THE FIELD.
22. CAUTION - DO NOT RUN LOW VOLTAGE WIRE (30 VOLTS MAXIMUM) IN CONDUIT OR RACEWAY WITH HIGHER VOLTAGE WIRE.
23. THE FOLLOWING CAPABILITIES ARE OPTIONAL - THEY ARE IMPLEMENTED & WIRED AS REQUIRED FOR A SPECIFIC APPLICATION.
 - A. UNIT DISCONNECT SWITCH - NON FUSED (AVAILABLE ON ALL CONTROL OPTIONS)
 - B. HOT GAS BYPASS (AVAILABLE ON ALL CONTROL OPTIONS)
 - G. RETURN AIR SENSOR (AVAILABLE WITH "CONSTANT VOLUME" CONTROL)
 - I. FLOW SWITCH (AVAILABLE WITH "EVP" CONTROL)
24. SUPPLY CONDUCTORS MUST BE SIZED PER AMPACITIES BASED ON 60 °C WIRE.

IMPORTANT!
DO NOT ENERGIZE
UNIT UNTIL CHECK-OUT
AND START-UP PROCEDURE
HAS BEEN COMPLETED

Figure 48. Field connection diagram RAUJ 80 to 120 tons – no system control

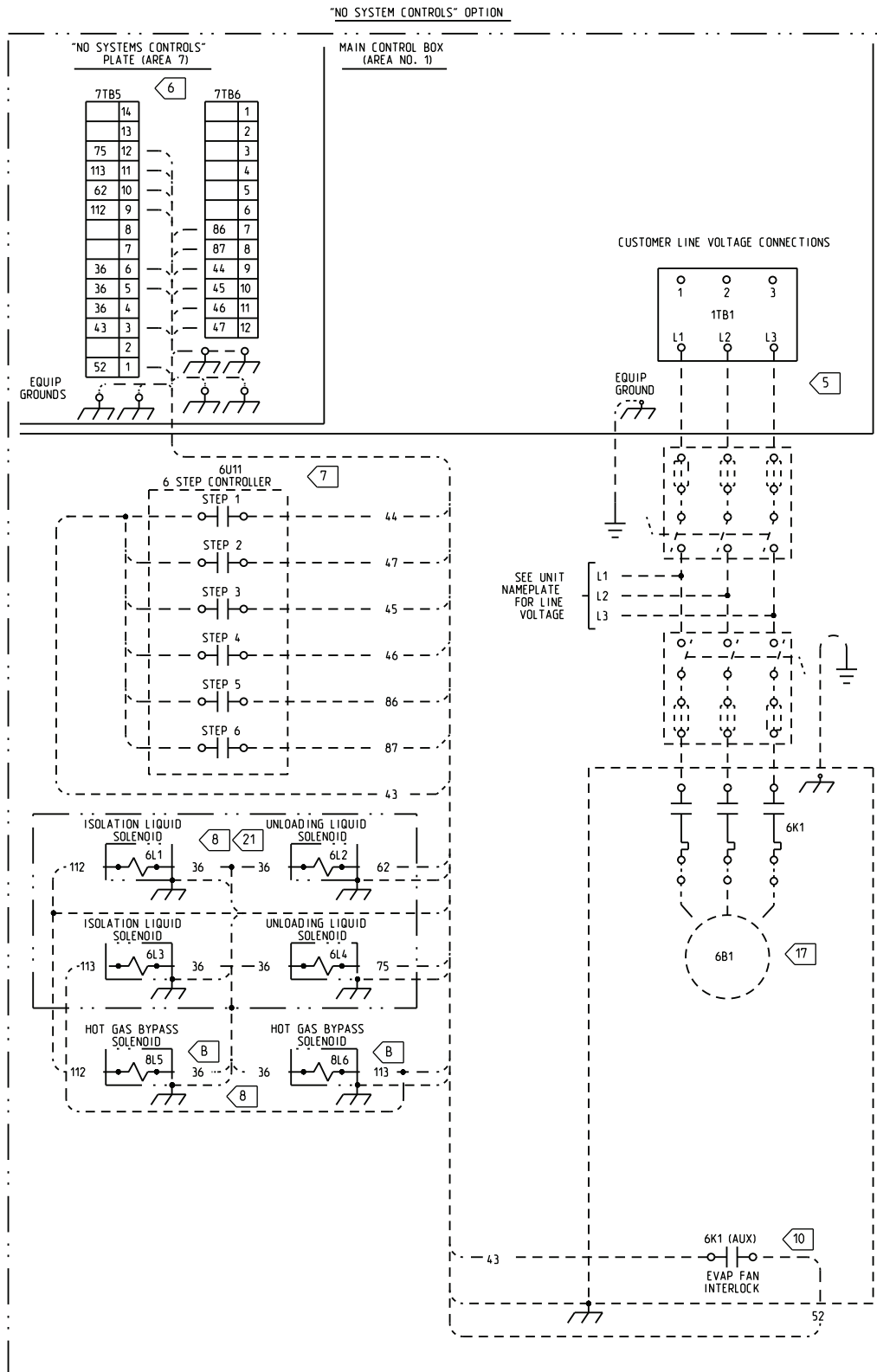

2307-9144



Installation Electrical

Figure 49. Field connection diagram RAUJ 80 to 120 tons — all system control

NOTE:

1. ALL WIRING AND COMPONENTS SHOWN DASHED TO BE SUPPLIED AND INSTALLED BY CUSTOMER IN ACCORDANCE WITH LOCAL AND NATIONAL ELECTRICAL CODES.
2. ALL WIRING TO BE N.E.C. CLASS 1 UNLESS OTHERWISE SPECIFIED.
3. CAUTION -- DO NOT ENERGIZE UNIT UNTIL CHECK-OUT AND START-UP PROCEDURES HAVE BEEN COMPLETED.
4. ALL THREE PHASE MOTORS ARE PROTECTED UNDER PRIMARY SINGLE PHASE FAILURE CONDITIONS.
5. SEE TABLE OF ACCEPTABLE WIRE SIZES FOR CONNECTION TO MAIN UNIT TERMINAL BLOCK (1TB1) OR DISCONNECT SWITCH (1S1).
6. SIZE CONTROL WIRING SUCH THAT TOTAL WIRE RESISTANCE OF THE RUN DOES NOT EXCEED 6 OHMS. SEE TABLE FOR WIRE SELECTION.
7. 6 STEP CONTROLLER (6U11) MIN. RATING - N.O. CONTACTS = 150 VA INRUSH/75 VA SEALED; N.C. CONTACTS = 80 VA INRUSH/40 VA SEALED.
8. ISOLATION LIQUID SOLENOID VALVES (6L1,6L3), UNLOADING LIQUID SOLENOID VALVES (6L2,6L4) AND HOT GAS BYPASS VALVES (8L5,8L6) -- MAX. SOLENOID RATINGS ARE 72 VA INRUSH/30 VA SEALED.
9. EVAPORATOR OR CIRCULATING PUMP CONTROL CIRCUIT MAX. RATINGS ARE 240 VA INRUSH/40 VA SEALED.
10. STARTER INTERLOCK (6K1 AUX), OUTSIDE AIR T-STAT (6S57), SYSTEM ON/OFF SWITCH (6S1), STARTER OVERLOAD RELAY (6K1 OL) AND FLOW SWITCH (8S58) MIN. RATINGS ARE 250 VA INRUSH/125 VA SEALED.
12. REMOVE RESISTOR (7R5 - 7TB8-4 & 5) WHEN FIELD SUPPLIED ECONOMIZER IS REQUIRED WITH OPTIONAL VARIABLE AIR VOLUME ("VAV") CONTROLS.
13. WIRING FOR CHILLER TEMP SENSOR (8RT2) AND DISCHARGE AIR SENSOR (8RT3) MUST BE SHIELDED CABLE AND NOT RUN IN CONDUIT WITH OTHER WIRING. FOR RUNS UNDER 500 FEET USE 16 GA (MIN) WIRE. FOR RUNS FROM 500 TO 1000 FEET USE 14 GA (MIN) WIRE. MAXIMUM RUN IS 1000 FEET. GROUND SHIELD AT ONE END ONLY.
14. SUGGESTED SYSTEM CONTROL SWITCH (6S2) FOR "VAV" CONTROLS OPTION IS CUTLER HAMMER 7580K5 SPST TOGGLE SWITCH OR EQUIVALENT.
15. WHEN NIGHT SETBACK IS REQUIRED WITH OPTIONAL "VAV". PROVIDE A CONTACT CLOSURE SUITABLE FOR A DRY CIRCUIT WITH MIN. RATING OF 125 VA/24 VAC - PILOT DUTY. REMOVE JUMPER (7TB7-4 & 5) WHEN REQUIRED.
16. OUTSIDE AIR T-STAT (6S57) IS REQUIRED ONLY WITH "EVP" OPTION - FOR LOW AMBIENT COMPRESSOR LOCKOUT.
17. CIRCUIT AS SHOWN IS FOR A CUSTOMER SUPPLIED EVAPORATOR FAN MOTOR (6B1) AND EVAP FAN STARTER (6K1). WHEN "EVP" OPTION IS REQUIRED, THIS CIRCUIT BECOMES A CIRCULATING PUMP MOTOR (6B1) AND A CIRCULATING PUMP STARTER (6K1).
18. INSTALL JUMPER (8TB9-7 & 8) WHEN HOT GAS BYPASS OPTION IS REQUIRED WITH OPTIONAL "EVP". INSTALL HOT GAS BYPASS SOLENOID VALVE (8L5) AS SHOWN.
19. CAUTION - DO NOT RUN LOW VOLTAGE WIRE (30 VOLTS MAXIMUM) IN CONDUIT OR RACEWAY WITH HIGHER VOLTAGE WIRE.
20. THE FOLLOWING CAPABILITIES ARE OPTIONAL - THEY ARE IMPLEMENTED AND WIRED AS REQUIRED FOR A SPECIFIC APPLICATION.
 - B HOT GAS BYPASS (AVAILABLE ON ALL CONTROL OPTIONS)
 - T FLOW SWITCH (AVAILABLE WITH "EVP" CONTROL)
21. ISOLATION LIQUID SOLENOID VALVES (6L1, 6L3) ARE REQUIRED FOR CHARGE ISOLATION (PROVIDED & INSTALLED BY THE FIELD). UNLOADING LIQUID SOLENOID VALVES (6L2, 6L4), IF APPLICABLE, ARE PROVIDED & INSTALLED BY THE FIELD.

Variable Air Volume Control (Honeywell W7100A)

In a variable air volume system, the desired space temperature is maintained by varying the amount of conditioned air being delivered to the space. As the cooling requirements of the space decreases, less air is delivered to the zone; conversely, as the cooling requirements of the space increases, a greater volume of air is delivered to the zone.

The descriptions of the following basic input devices used with the Honeywell W7100A discharge air controller are to acquaint the operator with their function as they interface with the controller. Refer to field connection diagram numbers 2307-9122 (for 20-60) and 2307-9144 (for 80-120) for the specific component connections at the unit control panel.

For discussion of evaporator fan interlock, hot gas bypass, and economizer connections, see "Wiring Requirements," p. 63.

Figure 50. Field connection diagram RAUJ 20 to 60 tons – variable air volume control

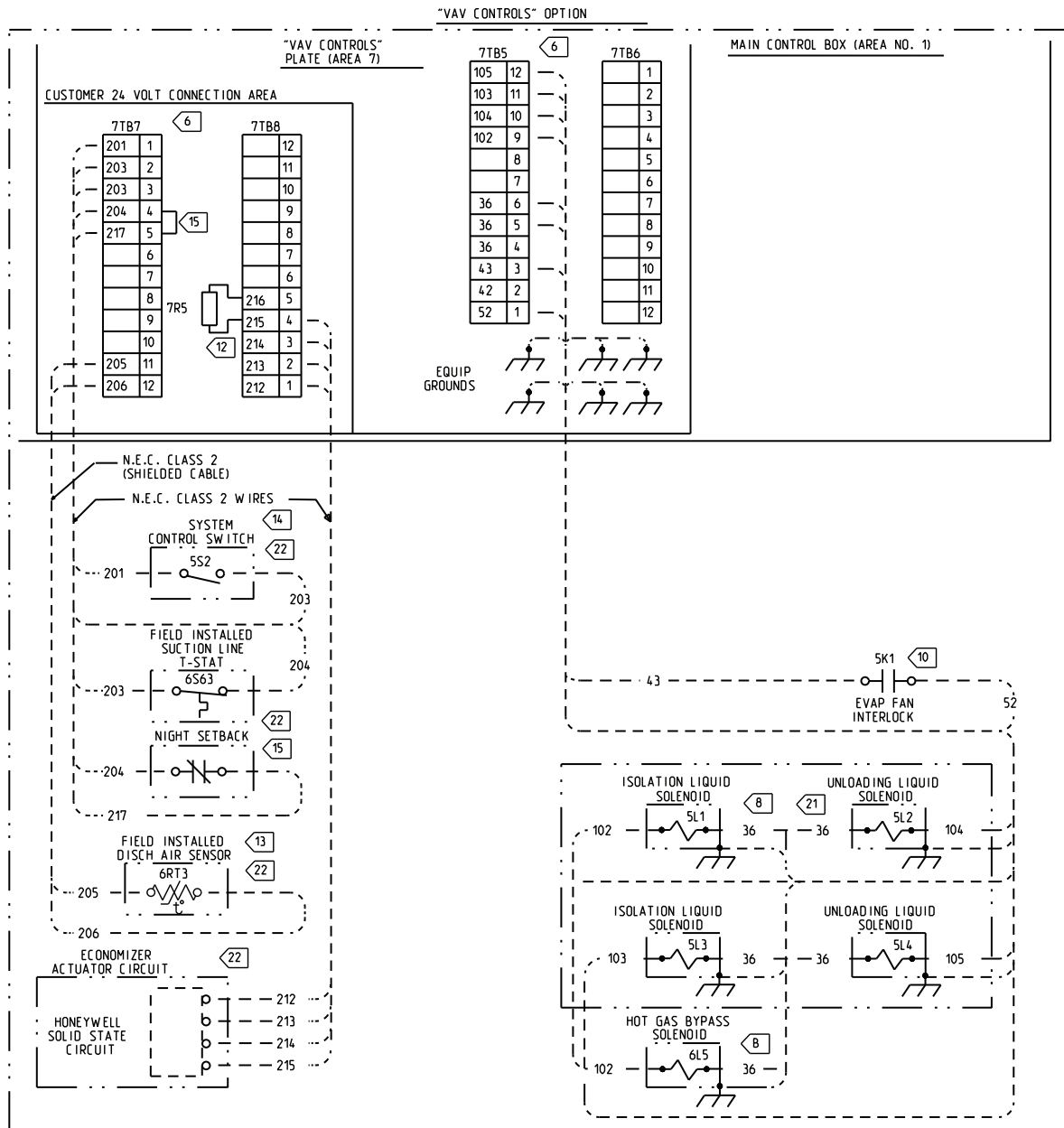

Note: See wiring notes on Figure 47, p. 72.

Figure 51. Field connection diagram RAUJ 80 to 120 tons – variable air volume control

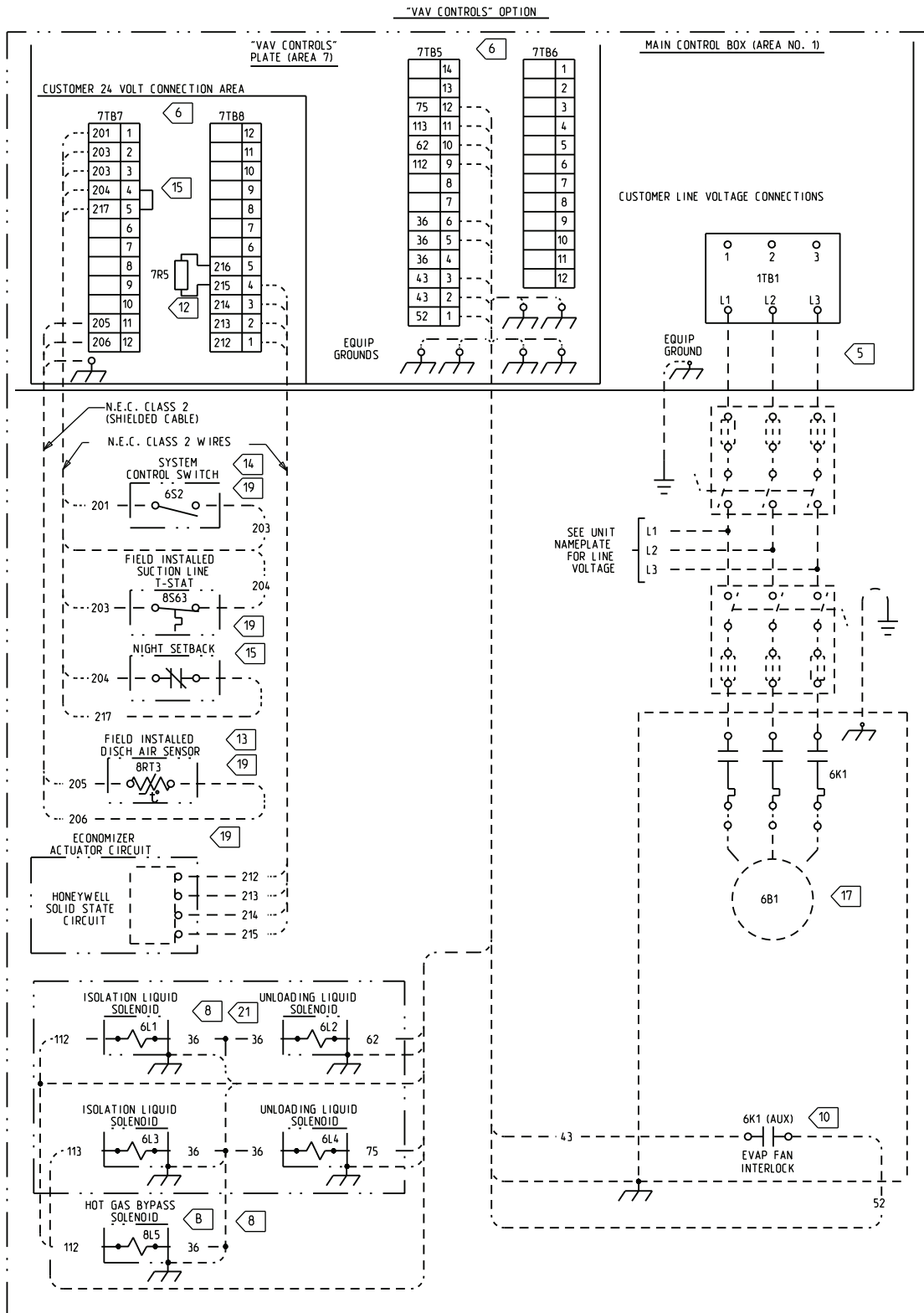

2307-9144

Note: See wiring notes on Figure 49, p. 74.

Discharge Air Sensor (Honeywell 6RT3 or Honeywell 8RT3)

Each unit ordered with variable air volume controls (digit 9 in the model number) is shipped with a Honeywell 6RT3 or 8RT3 discharge air sensor.

⚠ WARNING

Hazardous Voltage!

Failure to disconnect power before servicing could result in death or serious injury. Disconnect all electric power, including remote disconnects before servicing. Follow proper lockout/tagout procedures to ensure the power can not be inadvertently energized. Verify that no power is present with a voltmeter.

⚠ WARNING

Proper Field Wiring and Grounding Required!

Failure to follow code could result in death or serious injury. All field wiring MUST be performed by qualified personnel. Improperly installed and grounded field wiring poses FIRE and ELECTROCUTION hazards. To avoid these hazards, you MUST follow requirements for field wiring installation and grounding as described in NEC and your local/state/national electrical codes.

Install sensor in a turbulent free area of discharge air duct where it will provide accurate supply air sensing figure below for installation and sensor dimensions.

Figure 52. Discharge air sensor assembly

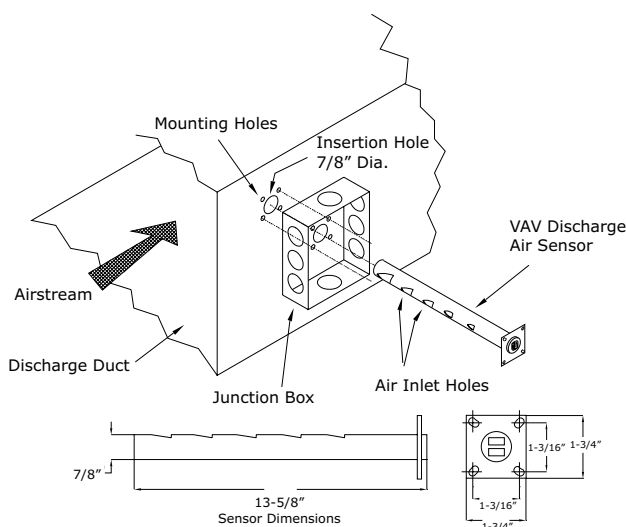

The sensor serves two functions:

- Sends supply air temperature data to Discharge Air Controller as an analog input, to control the

economizer (if applicable) and cycling of compressors

- Low limit sensor for system when supply air temperature reaches too high a delta T between actual supply air temperature and supply air temperature setpoint.

Before installing any connecting wiring, see drawings in Dimensions and Weights chapter for electrical access locations. Wire sensor per field connection diagram, numbers 2307-9122 (for 20-60) and 2307-9144 (for 80-120). Shielded cable (Belden 8760 or equivalent) must be used when wiring sensor to the terminal board inside unit control panel.

Connect shielded cable to appropriate terminals on terminal board (7TB7), in control panel.

Ground shield (at unit only) using ground screw in customer 24 volt connection area as shown in field connection diagram.

Suction Line Thermostat

⚠ WARNING

Hazardous Voltage!

Failure to disconnect power before servicing could result in death or serious injury. Disconnect all electric power, including remote disconnects before servicing. Follow proper lockout/tagout procedures to ensure the power can not be inadvertently energized. Verify that no power is present with a voltmeter.

Each unit ordered with variable air volume controls (digit 9 in the model number) is shipped with a suction line thermostat (6S63) that must be field installed.

Locate the thermostat close to the expansion valve bulb on a slightly flattened portion of the suction line. The thermostat must be securely fastened to the suction line and a field provided thermoconductive grease must be applied to the area to ensure good heat transfer.

Before installing any connecting wiring, see drawings in Dimensions and Weights chapter for electrical access locations. Wire suction line thermostat per field connection diagram, numbers 2307-9122 (for 20-60) and 2307-9144 (for 80-120). See [Table 22, p. 68](#) (AC Conductors) for wiring specifications.

Insulate the suction line, where the thermostat is mounted, to isolate it from the surrounding air.



Night Setback

⚠ WARNING

Hazardous Voltage!

Failure to disconnect power before servicing could result in death or serious injury.

Disconnect all electric power, including remote disconnects before servicing. Follow proper lockout/tagout procedures to ensure the power can not be inadvertently energized. Verify that no power is present with a voltmeter.

If night setback operation is desired, connect a set of normally open contacts (field provided) to the appropriate terminals on the terminal board (7TB7), in the unit's control panel. Remove the factory installed jumper at the terminal board when making the final wiring termination. Refer to the field connection diagram, numbers 2307-9122 (for 20 to 60 ton units) and 2307-9144 (for 80 to 120 ton units) for details.

W7100G Discharge Chilled Water Controller

The discharge chilled water controller (6U11) is shipped from the factory with a combination wire/resistor type jumper installed across Terminals 6, 7, & 8. The resistive portion of the jumper is across Terminals 7 & 8, which set the number of operating stages, of the control. As shipped, a 200 ohm resistive jumper is installed across Terminals 7 & 8 on the controller. The 200 ohm resistive jumper is required for two (2) stage operation on 20 through 30 Ton units. If the unit is a 20, 25, or 30 Ton unit, locate the bag that is secured to the controller, and discard it.

⚠ WARNING

Hazardous Voltage!

Failure to disconnect power before servicing could result in death or serious injury.

Disconnect all electric power, including remote disconnects before servicing. Follow proper lockout/tagout procedures to ensure the power can not be inadvertently energized. Verify that no power is present with a voltmeter.

40 to 60 Ton Units

For 40 to 60 ton units requiring four (4) stages of operation, a 402 ohm resistive jumper must be

installed across Terminals 7 & 8 on the controller. Remove the combination wire/resistor jumper containing the 200 ohm resistor from Terminals 6, 7, & 8. Locate the bag that is secured to the controller, and install the 402 ohm combination jumper across Terminals 6, 7, & 8 on the controller. Refer to the remote panel illustration for the terminal identification.

Note: *The resistor portion of the combination jumper must be installed across Terminals 7 & 8 on the controller.*

80 to 120 Ton Units

For 80 to 120 ton units requiring six (6) stages of operation, a 604 ohm resistive jumper is needed across Terminals 7 & 8 on the controller. This jumper is factory installed.

The descriptions of the following input devices are to acquaint the operator with their function as they interface with the Honeywell W7100G controller.

Note: *All wiring must comply with local and national electrical codes (NEC).*

Outside Air Thermostat (5S57 Field Provided)

The setpoint for the outside air thermostat is based upon the working ambient selected when the unit was ordered. A Zero ("0") in the 11th digit of the model number indicates the system is designed for standard ambient operation of 40°F and above. A One ("1") in the 11th digit of the model number indicates the system is designed for low ambient operation of 0°F and above. Therefore, select a thermostat with the appropriate operating range based on the unit specifications. See field connection diagram for the specific connection points inside the remote panel.

Constant Volume Control (Honeywell W973) — 20 - 60 Ton Units Only

The descriptions of the following basic input devices used with the Honeywell W973 Master Energy Controller (MEC) are to acquaint the operator with their function as they interface with the controller. Refer to field connection diagram, number 2307-9122, for the specific component connections at the unit's control panel.

Figure 53. Field connection diagram, RAUJ 20 to 60 tons – constant volume control applications

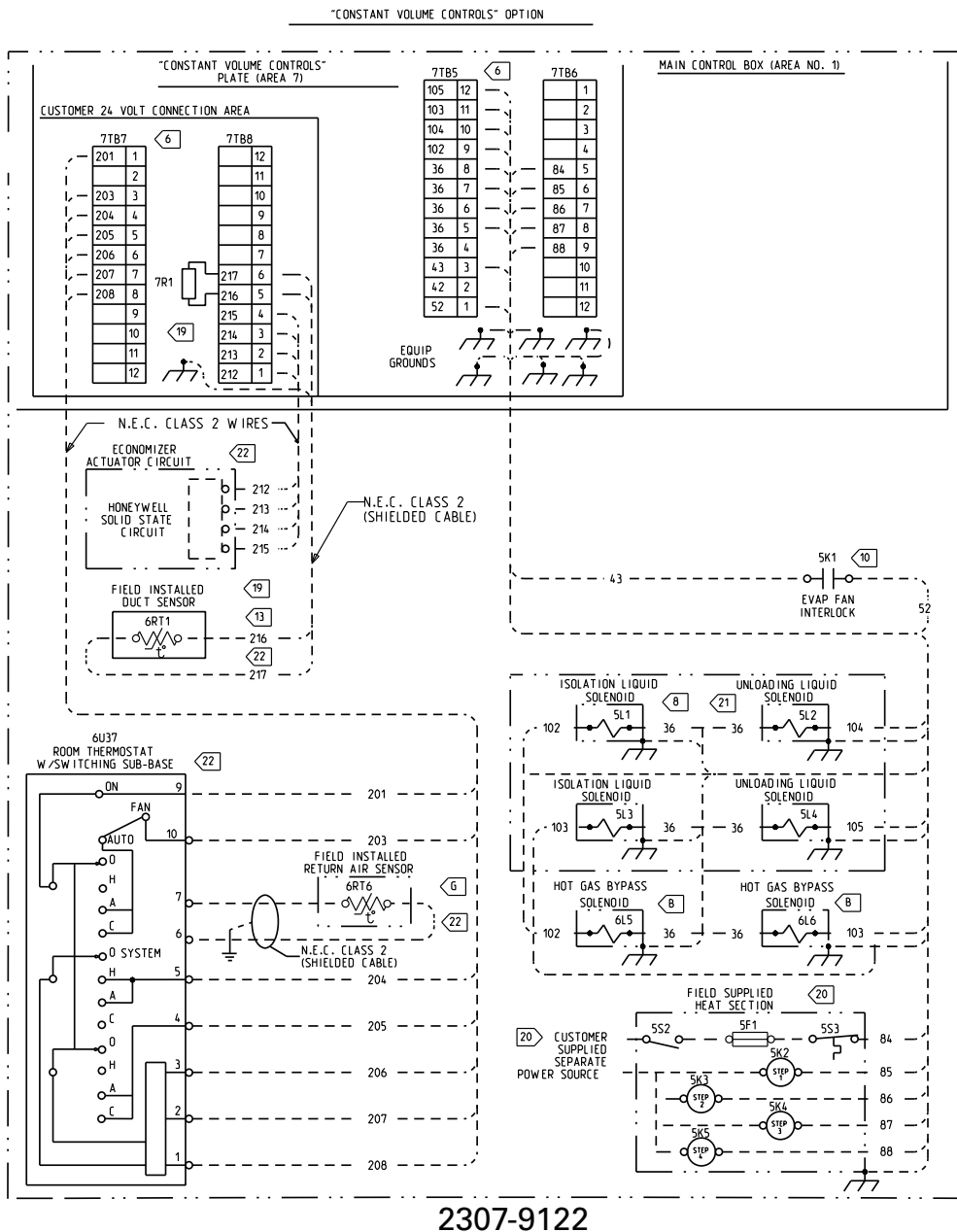

Note: See wiring notes on Figure 47, p. 72.

Electronic Zone Thermostat (Honeywell T7067)

Each unit ordered with constant volume controls (in the model number) is shipped with a Honeywell T7067 electronic zone thermostat. A Honeywell switching subbase (Q667) is also included. The switching subbase allows the operator to select the "System Mode" of operation, i.e., Cool, Heat, Auto, or Off and the "Fan Mode" of operation, i.e., On or Auto.

Note: As long as the status of the system is in an occupied mode, the supply fan will operate continuously. The fan will only cycle in the "Auto" mode during unoccupied periods.

The zone thermostat should be located in an area with good air circulation to enhance zone temperature averaging. Position the thermostat about 54" above the floor in a frequently occupied area.

Do not mount the thermostat where its sensing element may be affected by:

- Drafts or "dead" spots behind doors or in corners;



Installation Electrical

- Hot or cold air from ducts;
 - Radiant heat from the sun, or from appliances;
 - Concealed pipes and chimneys;
 - Vibrating surfaces; or
 - Unconditioned areas behind the thermostat (e.g., outside walls).
- Mount the thermostat subbase on either a standard 2" X 4" handy box, a comparable European outlet box, or on any nonconductive flat surface. See illustration below for mounting details.

Figure 54. T7067 electronic zone thermostat & Q667 switching subbase

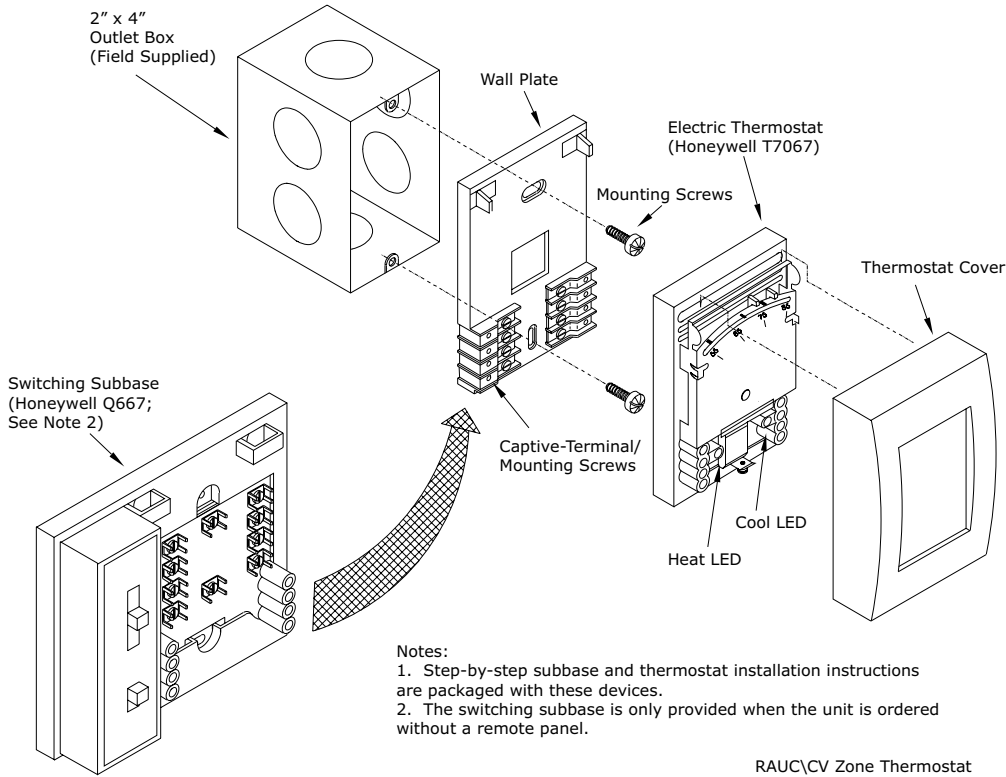

Note: Specific installation instructions are packaged with each thermostat and subbase. For subbase and thermostat terminal identification, see figure below.

Figure 55. Q667 switching subbase & T7067 thermostat terminal identification

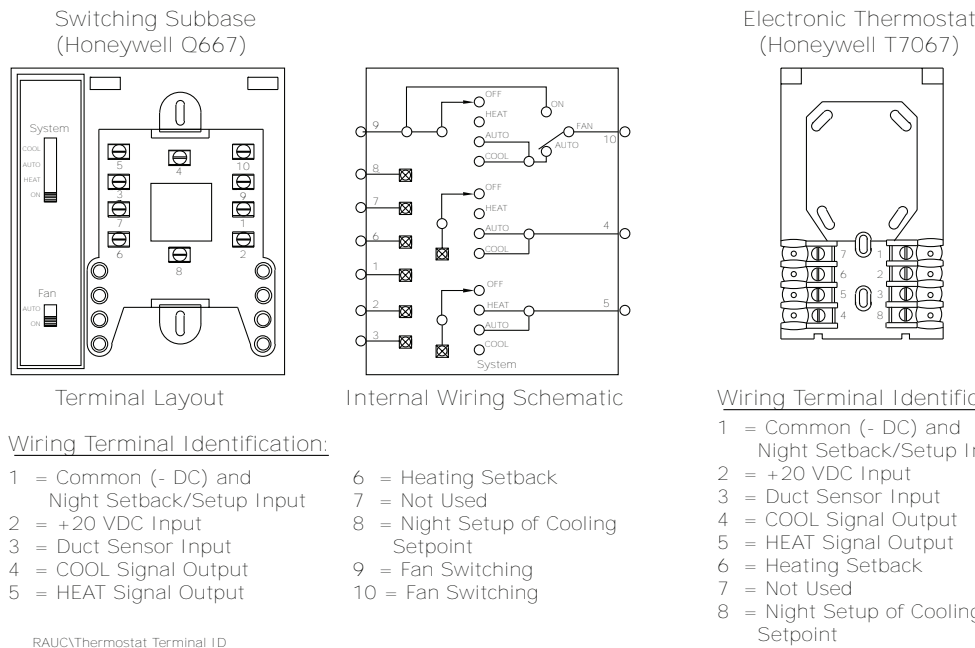

Table 26. (Q667) switching subbase

Subbase Switch Positions		Check Continuity between These Terminal Pairs	Circuit should be
Fan	System		
ON	N/A	9 (Subbase) & 10 (Subbase)	Closed
AU-TO	OFF	9 (Subbase) & 10 (Subbase)	Open
		5 (Subbase) & 5 (T'stat)	Open
AU-TO	HEAT	9 (Subbase) & 10 (Subbase)	Open
		5 (Subbase) & 5 (T'stat)	Closed
		4 (Subbase) & 4(T'stat)	Open
AU-TO	AUTO	9 (Subbase) & 10 (Subbase)	Closed
		5 (Subbase) & 5 (T'stat)	Closed
		4 (Subbase) & 4(T'stat)	Closed
AU-TO	COOL	9 (Subbase) & 10 (Subbase)	Closed
		5 (Subbase) & 5 (T'stat)	Open
		4 (Subbase) & 4(T'stat)	Closed

Thermostat Checkout

Once the subbase is mounted, before connecting any wiring, use an ohm meter and complete the continuity checks listed in [Table 26, p. 81](#).

Thermostat Wiring

⚠ WARNING

Hazardous Voltage!

Failure to disconnect power before servicing could result in death or serious injury. Disconnect all electric power, including remote disconnects before servicing. Follow proper lockout/tagout procedures to ensure the power can not be inadvertently energized. Verify that no power is present with a voltmeter.

Before installing any connecting wiring, see drawings in the Dimensions and Weights chapter for the electrical access locations provided on the unit. Wire the thermostat in accordance with field connection diagram, numbers 2307-9122 (for 20 to 60 ton units) and 2307-9144 (for 80 to 120 ton units).

Discharge Air Sensor (Honeywell 6RT1)

A discharge air sensor ships with each unit when the constant volume control option is ordered. The sensor should be installed in a turbulent free area of the discharge air duct at a location that will provide accurate supply air sensing. Refer to the illustration in [Figure 52, p. 77](#) for installation and sensor dimensional information.

⚠ WARNING

Hazardous Voltage!

Failure to disconnect power before servicing could result in death or serious injury.

Disconnect all electric power, including remote disconnects before servicing. Follow proper lockout/tagout procedures to ensure the power can not be inadvertently energized. Verify that no power is present with a voltmeter.

Wire the sensor in accordance with field connection diagram, numbers 2307-9122 (for 20-60) and 2307-9144 (for 80-120). As shipped from the factory, a resistor (7R1) is installed on terminal board 1TB8 terminals 5 & 6). Remove this resistor when the sensor is installed. Shielded cable (Belden 8760 or equivalent) must be used when wiring the sensor to the terminal board inside the unit's control panel.

When the sensor is installed, it serves two functions;

- It sends the supply air temperature to the master energy controller (MEC), in the form of an analog input, to assist in the rate at which the system changes the space temperature. By offsetting the actual zone thermostat setpoint, up or down, the MEC can closer control the zone comfort level.
- It serves as a low limit for the system when the supply air temperature reaches too high a delta tee between the actual supply air temperature and the zone temperature to help prevent overshooting of the zone thermostat setpoint.

EVP Chiller Control

Each unit ordered for EVP Chiller applications (digit 9 in the model number), is shipped with the following controls:

- EVP Remote Panel w/ W7100G Controller
- Freezestat (6S12)

- Chiller Water Temperature Sensor (6RT2)
- Freezestat Bulb well
- Chilled Water Temperature Sensor Well

The installation of the freezestat bulb well, freezestat bulb, and the chilled water temperature sensor was discussed in the "Chilled Water Piping" section. Refer to that section for their installation locations and dimensional data.

The chiller control (located in the remote panel) controls the system operation by responding to the leaving water temperature. The remote panel must be mounted indoors and within 20 feet of the chiller. Figure below illustrates the remote panel dimensional data, the component locations, the locations for the ship-with items, grounding lugs, and the field connection terminal board 6TB9. Refer to the field connection diagram illustrated in [Figure 57, p. 83](#) (20 to 60 ton units) and [Figure 58, p. 84](#) (80 to 120 ton units) for the interconnecting points between the remote panel and the unit's control panel.

Figure 56. EVP chiller remote panel

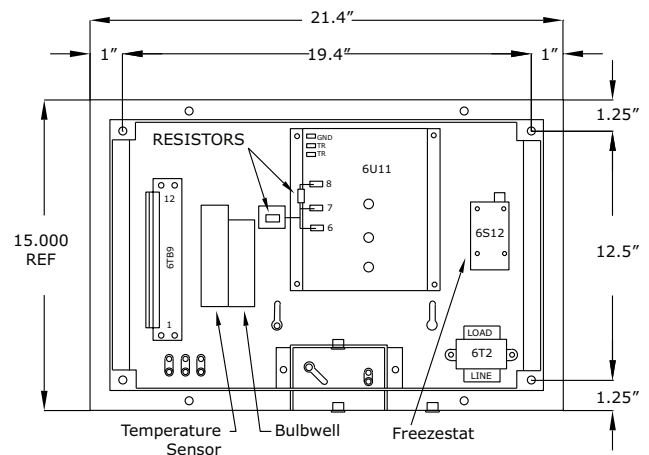
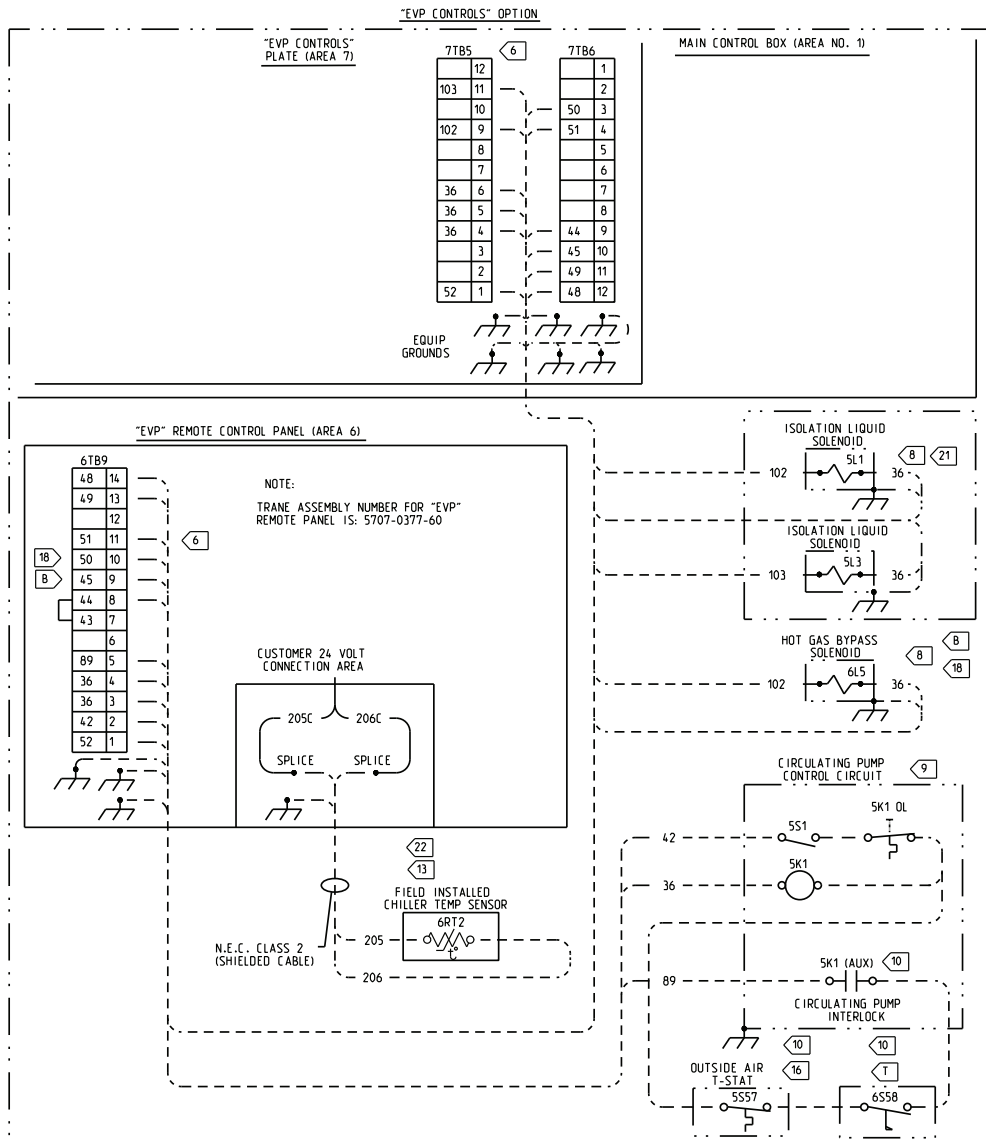
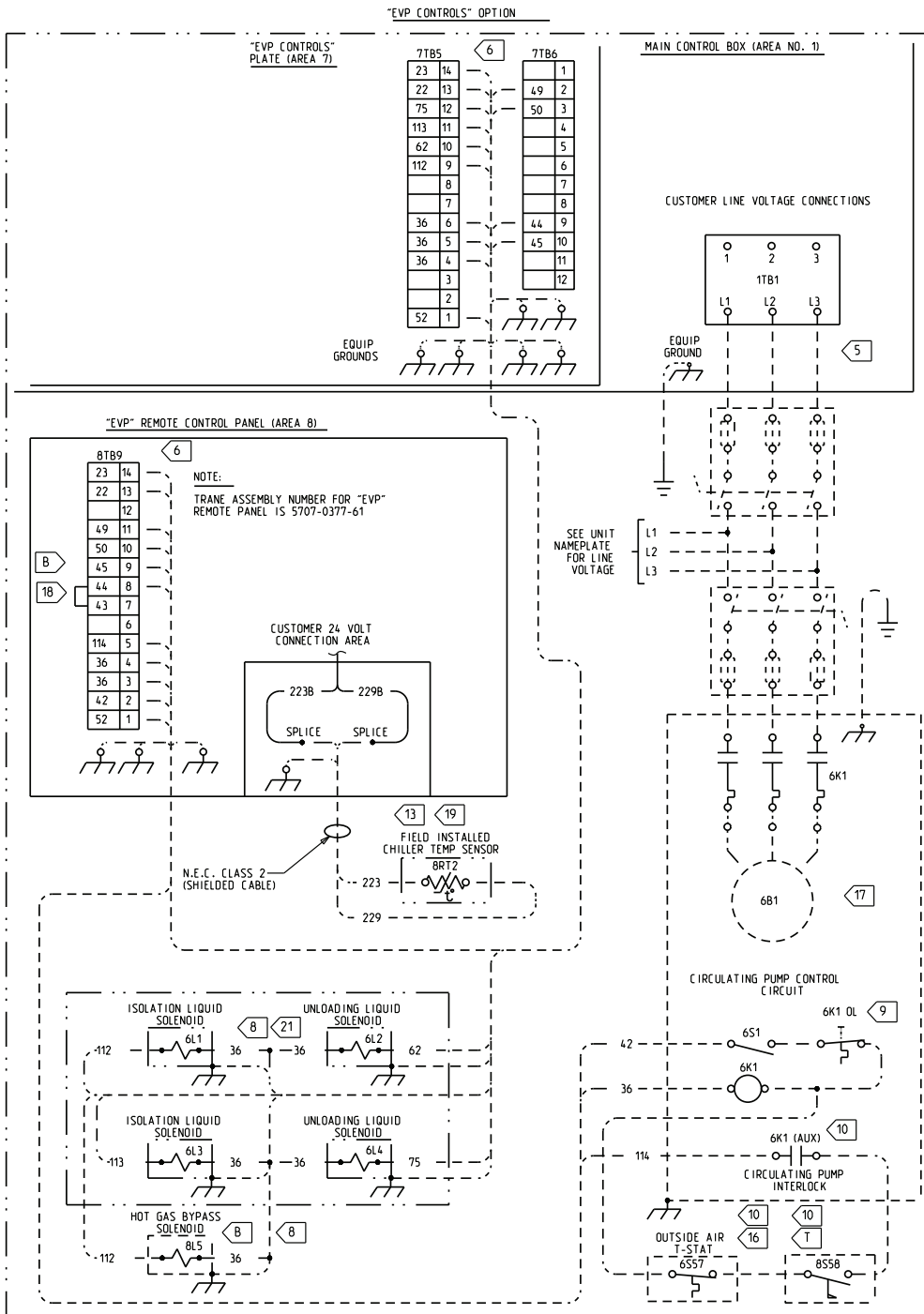

Figure 57. Field connection diagram - RAUJ-C20-60 - EVP chiller applications



Note: See wiring notes on previous figure "Field Connection Diagram Notes RAUJ 20 to 60 tons – No System Controls".

Figure 58. Field connection diagram, RAUJ 80 to 120 tons – EVP chiller applications



Note: See wiring notes on previous figure "Field Connection Diagram Notes RAUJ 80 to 120 tons – No System Controls".

⚠ WARNING**Proper Field Wiring and Grounding Required!**

Failure to follow code could result in death or serious injury.

All field wiring **MUST** be performed by qualified personnel. Improperly installed and grounded field wiring poses **FIRE** and **ELECTROCUTION** hazards. To avoid these hazards, you **MUST** follow requirements for field wiring installation and grounding as described in NEC and your local/state/national electrical codes.

A ground wire must be installed between the EVP remote panel and the unit control panel.

Operating Principles

Component Locations

Condenser Fans

Figure 59. Condenser fan locations: 20 to 60 ton units

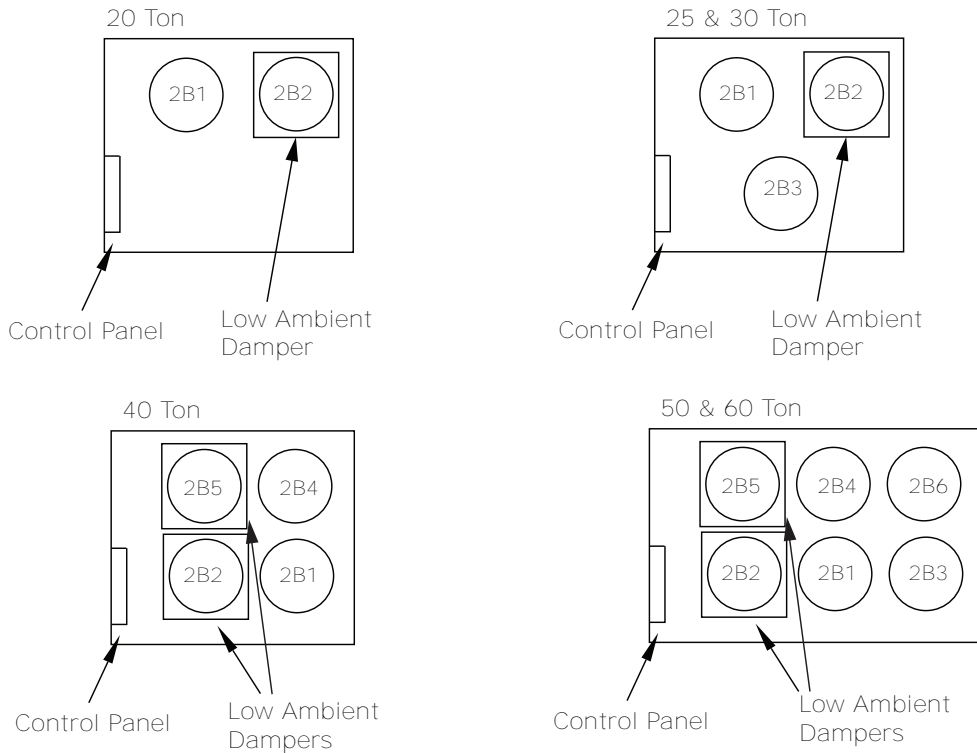
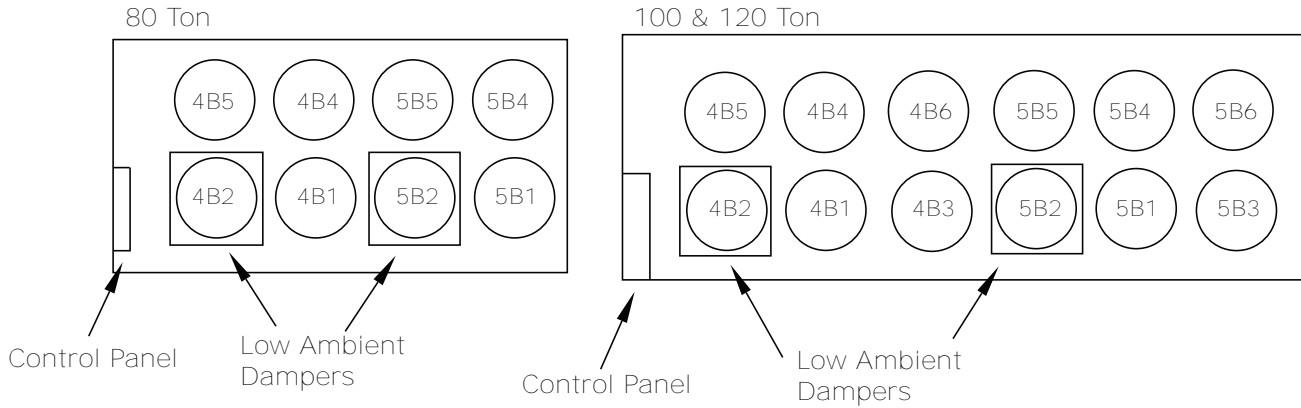

Figure 60. Condenser fan locations: 80 to 120 ton units



Compressors

Figure 61. Compressor locations: 20 to 60 ton units

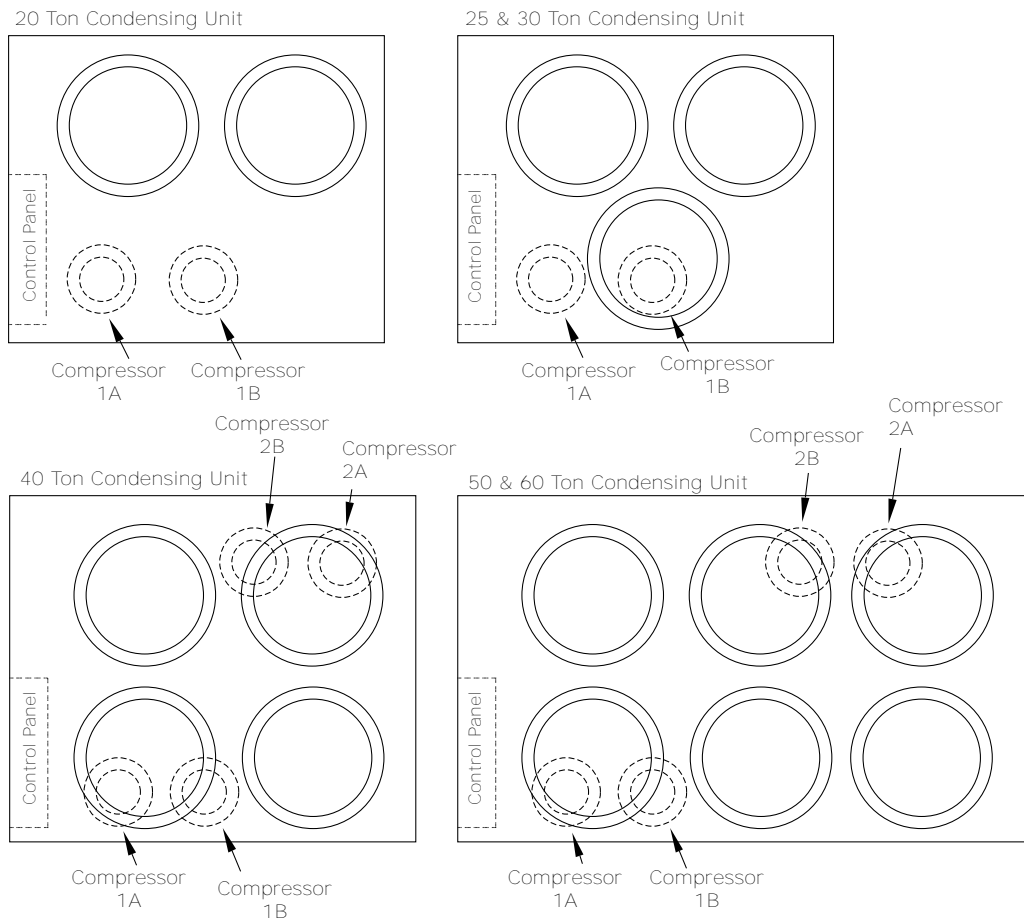
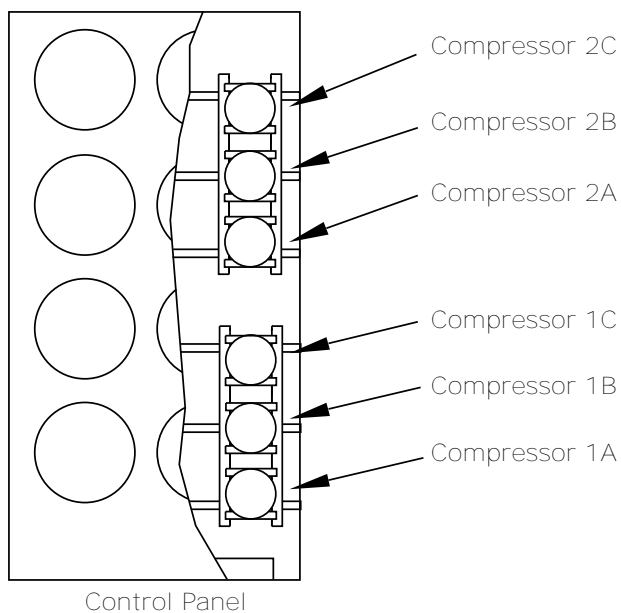
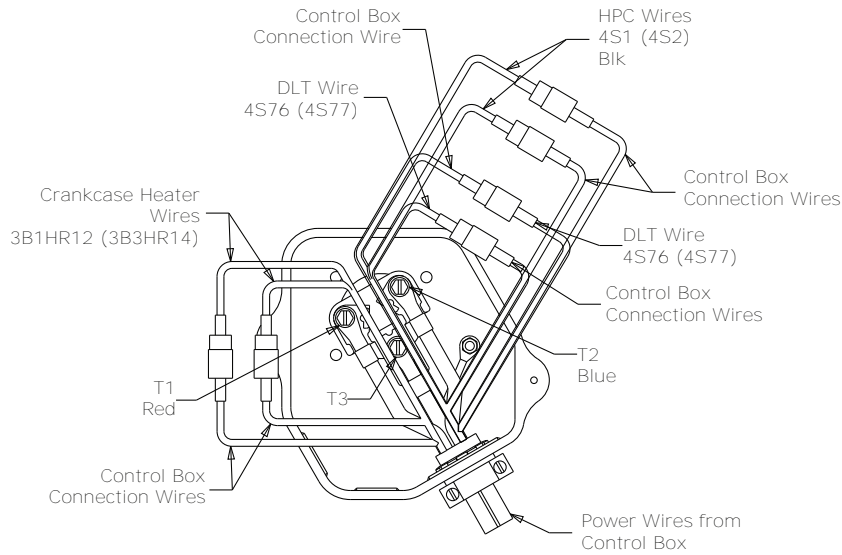

Figure 62. Compressor locations: 80-120 ton units



Compressor Junction Box

Figure 63. Junction box: 20-60 Ton units



1A (& 2A, if present) J-Box Shown w/o Cover

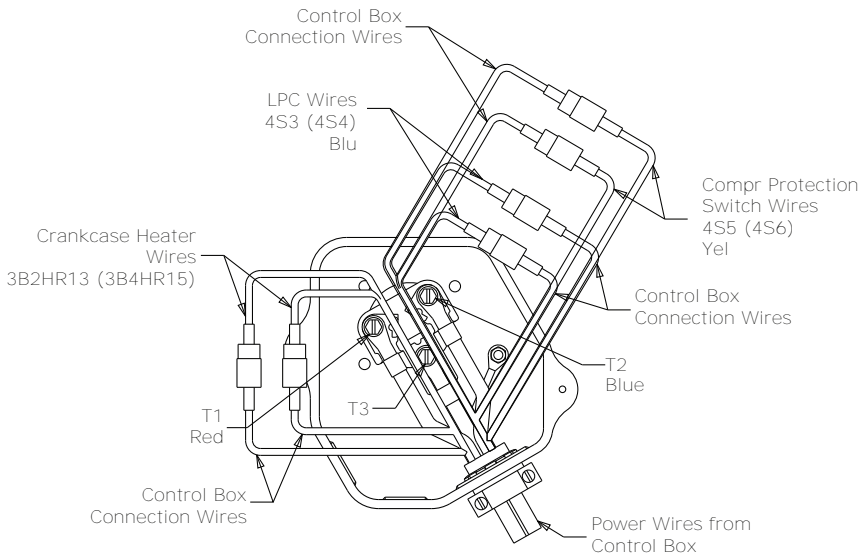

1B (& 2B, if present) J-Box Shown w/o Cover

Figure 64. Junction box: 80-120 Ton units

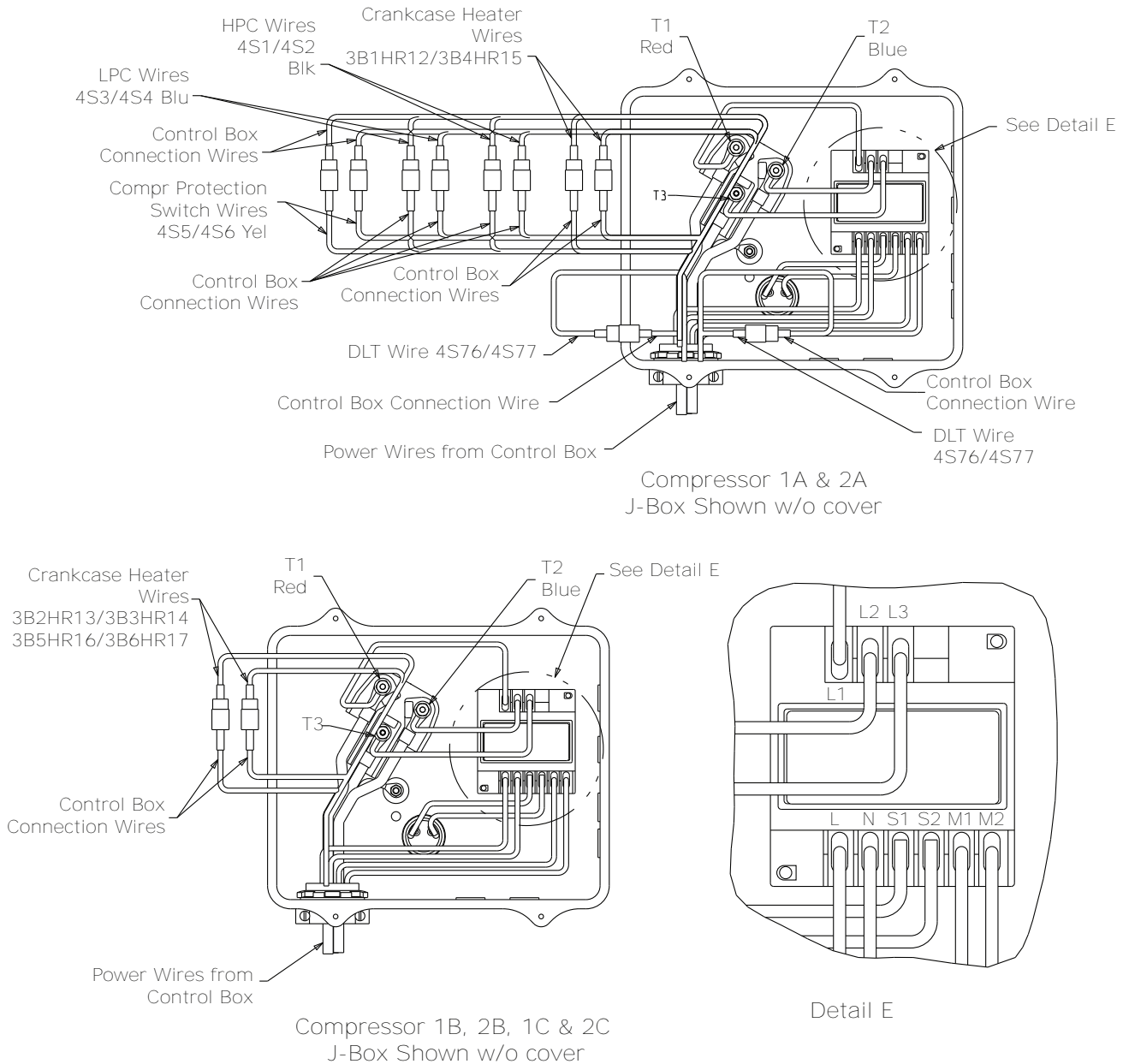

Unit Operation

VAV W7100A Discharge Air Controller (7U11)

The discharge air controller used in Variable Air Volume applications is a Honeywell W7100A. This microprocessor controller is designed to maintain an average discharge air (D/A) temperature by:

- Monitoring the discharge air temperature sensor; and

- Modulating economizer dampers and sequencing stages of mechanical cooling "On" or "Off", as required.

The W7100A receives analog input from the discharge air sensor mounted in the supply duct every 2 to 3 seconds by pulsing DC current across the sensor, then "reading" the voltage potential across this thermistor.

If the comparison between the setpoint and the actual discharge air temperature indicates that cooling is required, the W7100A attempts to satisfy the load by modulating the economizer open (if applicable).

Economizer Cycle

The economizer is only allowed to function if the ambient conditions are below the setpoint of the enthalpy switch.

If the ambient air conditions are above the enthalpy setpoint, the W7100A will open the Fresh Air dampers to the minimum setpoint position.

To take full advantage of the “free cooling” provided by the economizer, the W7100A “resets” the discharge air setpoint. The amount of “reset” between the actual discharge air setpoint and the economizer control point is equal to 1/2 of the W7100’s control band setpoint.

Example: With a typical control band setting of 6°F, the amount of discharge air “reset” is 3°F (1/2 of the control band setpoint). Therefore, if the discharge air setpoint is 55°F, the economizer control point is 52°F (i. e., 55°F - 3°F).

A second economizer “algorithm” within the W7100A is the response time of the controller. The greater the amount of deviation between the discharge air temperature and the economizer control point, i.e., as the temperature strays further from the control point, the response time becomes faster; and, as the discharge air temperature approaches the control point, the response time becomes slower.

When the discharge air temperature is within the “Deadband” ($\pm 1.5^\circ\text{F}$ of the economizer control point); the W7100A maintains the economizer’s present position.

When the economizer cannot handle the cooling requirement or when the outdoor ambient conditions are unsuitable for “economizing”, the W7100A activates the unit’s mechanical cooling section.

Note: *As long as ambient conditions are suitable for economizing, the economizer works in conjunction with the mechanical cooling operation.*

The control algorithm used by the W7100A to add stages of cooling is illustrated in the figure below. When the discharge air temperature drifts above the setpoint, “Region 1”, a stage of mechanical cooling is added based on time and the amount of deviation from setpoint. If the discharge air temperature remains above the setpoint, the W7100A energizes additional stages of mechanical cooling.

If the operating cooling stage is capable of satisfying the cooling requirement, as the discharge air temperature falls below the setpoint for a sufficient period of time, the W7100A turns the stages of mechanical cooling “Off”, “Region 3”.

The W7100A determines the length of the time before stages of mechanical cooling are turned “On” and “Off”. When the system is operating within the control band, the delay is longest at setpoint, and decreases to a minimum of 4 minutes when the discharge air temperature exceeds the upper or lower limit of the control band. See figure below.

Figure 65. W7100A staging sequence

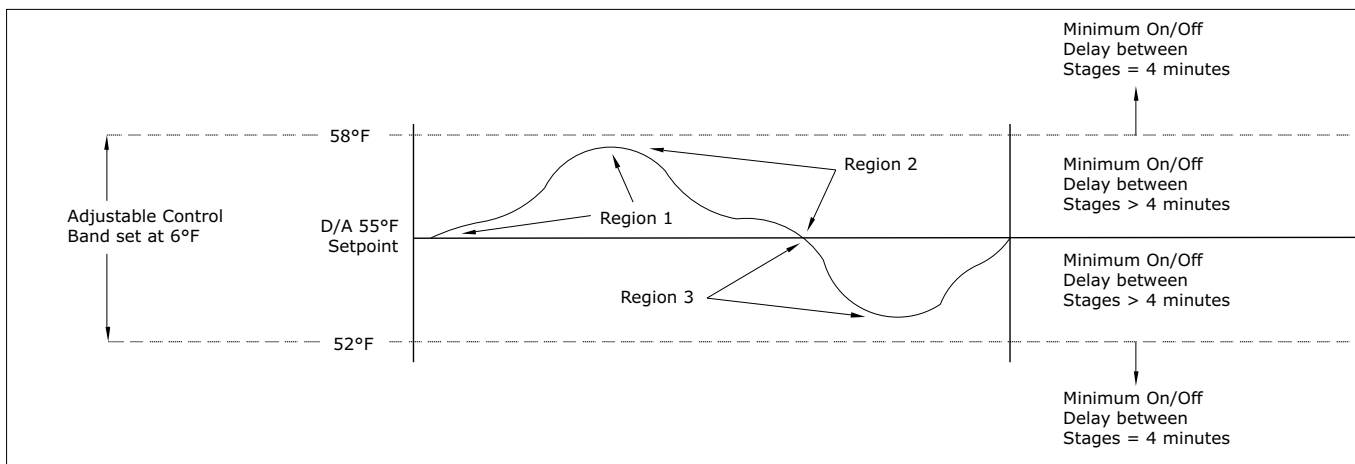

Chilled Water Temperature Controller (6U11)

The chilled water temperature controller used with EVP chiller applications is a Honeywell W7100G. This microprocessor controller is designed to maintain an average leaving water temperature using an integrating control band concept that matches the required operating capacity to the chiller load. The integral action, unlike “proportional only” type

controllers, minimizes the amount of offset from the control setpoint.

The control band setting is centered on the leaving water setpoint. It is adjustable from 0°F to 10°F [0°C to 6°C] and is used to stabilize system operation. The control algorithm used by the W7100G to add stages of cooling is illustrated in the figure below. As the water temperature rises above the upper control band limit, a stage of mechanical cooling is added, provided the

minimum "Off" time has been satisfied (Point A). The minimum "fast response" time and the time delay between staging for the W7100G is set for 60 seconds.

If the water temperature remains above the upper control band limit (Point B), the next available stage of cooling will be energized when the minimum time delay between stages has elapsed. As the water temperature decreases below the lower control band, the last stage that was turned "On" will be cycled "Off" (Point C) when the minimum "On" time for that stage has elapsed. As the load on the water increases due to cooling stages being cycled "Off", the controller will

maintain its current position, i.e., no staging of cooling "On" or "Off", as long as the temperature remains inside the control band. When the temperature increases above the upper control band limit (Point D), mechanical cooling stages will be sequenced "On" in the same manner as before. As a rule, any time the water temperature is above the upper control band limit, a stage of cooling will be "added" and anytime the water temperature decreases below the lower control band limit, a stage of cooling will be "Subtracted".

Figure 66. W7100G staging sequence

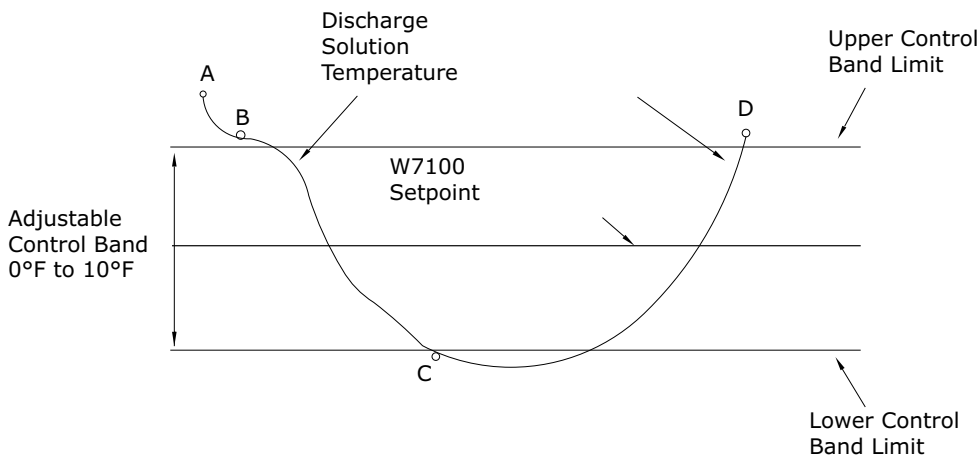

Thermostatic Expansion Valve

The reliability and performance of the refrigeration system is heavily dependent upon proper expansion valve adjustment. Therefore, the importance of maintaining the proper superheat cannot be over emphasized. See Thermal Expansion Valve Manufacturer Settings tables in Start-Up chapter for proper superheat adjustment. Accurate measurements of superheat will provide the following information.

- Effectiveness of expansion valve control of refrigerant flow.
- Efficiency of the evaporator coil.
- Amount of protection compressor is receiving against flooding or overheating.

The expected range for superheat is 14 to 18°F at full load conditions. At part load, expect a properly adjusted expansion valve to control to 8 to 12°F superheat. Systems operating with lower superheat could cause serious compressor damage due to refrigerant floodback.

The outdoor ambient temperature must be between 65°F and 105°F and the relative humidity of the air entering the evaporator must be above 40 percent.

When the temperatures are outside of these ranges, measuring the operating pressures can be meaningless.

Condenser Fans

20 to 60 Ton Specs

Condenser fan cycling is accomplished through interlocking the fan operation with compressor operation (1K1 & 1K3), liquid line pressure switches (4S11 & 4S12). When the low ambient option is applied, ambient temperature thermostats (1S36 & 1S37) are used to provide additional fan cycling control. [Table 27, p. 92](#) lists the condenser fan sequencing data. See "[Condenser Fans,](#)" [p. 86](#) for condenser fan locations and designators.

When a cooling command has been initiated, the first compressor for circuit 1 is energized. An auxiliary contact on the compressor contactor is closed, energizing contactor 1K6 and turning on fan 2B2. When the liquid line pressure exceeds 255 psig the fan pressure switch (4S11) will close and energize contactor 1K5, turning on fan 2B1.



Operating Principles

Table 27. RAUJ condenser fan sequencing data: 20 to 60 ton units

Controlling Device	Fan "ON"	Fan "OFF"	Fan Identification
Interlock Circuit 1	1K1 Closed	1K1 Open	2B2
Interlock Circuit 2	1K3 Closed	1K3 Open	2B5 ^(a)
Fan Temperature Switch ^(b)	1S36		
	33°F	30°F	2B3 ^(c)
	1S37		
	33°F	30°F	2B6 ^(d)
Fan Pressure Switch	4S11		
	444 psig	255 psig	2B1
	4S12		
	444 psig	255 psig	2B4 ^(a)

^(a) Fan used on 40, 50 and 60 ton units only.

^(b) 1S36 and 1S37 normally-closed contacts open on ambient temperature drop to 30°F. Contacts reclose on ambient temperature rise to 30°F and 33°.

^(c) Fan used on 25, 30, 50 and 60 ton units only.

^(d) Fan used on 50 and 60 ton units only.

80 to 120 Ton Specs

Condenser fan cycling is accomplished through interlocking the fan operation with compressor operation (1K1 & 1K4), liquid line pressure switches (4S7 & 4S8). [Table 28, p. 92](#) lists the condenser fan sequencing data. See ["Condenser Fans," p. 86](#) for condenser fan locations and designators.

When a cooling command has been initiated, the first compressor for circuit 1 is energized. An auxiliary contact on the compressor contactor is closed, energizing contactor 1K9 and turning on fan 4B2. When the liquid line pressure exceeds 255 psig the fan pressure switch (4S7) will close and energize contactor 1K7, turning on fans 4B1 and 4B4.

Table 28. RAUJ condenser fan sequencing data: 80 to 120 ton units

Controlling Device	Fan ON	Fan OFF	Fan Identification
Interlock Circuit 1	1K1 Closed	1K1 Open	4B2, 4B6 ^(a)
Interlock Circuit 1	1K1, 1K2 Closed	1K1, 1K2 Open	4B2, 4B5, 4B6 ^(a)
Interlock Circuit 2	1K4 Closed	1K4 Open	5B2, 5B6 ^(a)
Interlock Circuit 2	1K3, 1K4 Closed	1K3, 1K4 Open	5B2, 5B5, 5B6 ^(a)
Fan Pressure Switch	4S7		
	444 psig	255 psig	4B1, 4B4, 4B3 ^(a)
	4S8		
	444 psig	255 psig	5B1, 5B4, 5B3 ^(a)

^(a) Fan used on 100 and 120 ton units only.

Low Ambient Dampers

Low Ambient Dampers are available as a factory installed option or can be field-installed. Dampers are used to extend the operation of these units from the standard operational temperatures to a minimum of 0°F without hot gas bypass or 10°F with hot gas bypass. (These values apply when wind speed across the condenser coil is less than 5 m.p.h.). If typical wind speeds are higher than 5 m.p.h., a wind screen around the unit may be required. By restricting the airflow across the condenser coils, saturated condensing

temperatures can be maintained as the ambient temperatures change.

The low ambient damper actuator controls damper modulation for each refrigerant circuit in response to saturated condensing temperature.

Compressor Crankcase Heaters

Each compressor is equipped with a crankcase heater and is controlled by a 600 volt auxiliary switch on the compressor contactor. The proper operation of the crankcase heater is important to maintain an elevated compressor oil temperature during the "Off" cycle to

prevent low oil viscosity and foaming during compressor starts.

When the compressor starts, the sudden reduction in crankcase pressure causes the liquid refrigerant to boil rapidly causing the oil to foam. This condition could damage compressor bearings due to reduced lubrication and could cause compressor mechanical failures.

When power has been "Off" for an extended period, allow the crankcase heater to operate a minimum of 24 hours before starting the unit.

Low Ambient Thermostats

20 to 60 Ton Units

In addition to the low ambient dampers on 25, 30, 50 & 60 Ton units, a low ambient thermostat is installed to further restrict the airflow across the condenser by cycling the 2B3 condenser fan on 25 & 30 Ton units plus 2B6 on 50 & 60 Ton units. The thermostat opens

when the ambient temperature reaches 30°F and closes at approximately 33°F.

Hot Gas Bypass Operation

The HGBP valve regulates evaporator pressure by opening as suction pressure decreases, to maintain a desired minimum evaporating pressure regardless of a decrease in evaporator external loading.

When the evaporator (suction) pressure is above the valve's setpoint, it remains closed. As suction pressure falls below the valve's setpoint, the valve begins to open. The valve will continue to open at a rate proportional to the suction pressure drop, thus maintaining evaporator pressure.

Hot gas bypass valves are adjustable and should be set to begin opening at approximately 100 psig suction pressure and reach the full open position at 98 psig for DX coil applications.



Pre-Start

Use the checklist provided below in conjunction with the "General Unit Requirement" checklist to ensure that the unit is properly installed and ready for operation. Be sure to complete all of the procedures described in this section before starting the unit for the first time.

⚠ WARNING

Hazardous Voltage!

Failure to disconnect power before servicing could result in death or serious injury.

Disconnect all electric power, including remote disconnects before servicing. Follow proper lockout/tagout procedures to ensure the power can not be inadvertently energized. Verify that no power is present with a voltmeter.

- Turn the field supplied disconnect switch, located upstream of the unit, to the "Off" position.
Note: Verify that the 115 volt control switch (1S2) in the unit control box is in the "Off" position.
- Turn the "System" selection switch (at the Remote Panel) to the "Off" position and the "Fan" selection switch (if applicable) to the "Auto" or "Off" position.
- Check all electrical connections for tightness and "point of termination" accuracy.
- Verify that the condenser airflow will be unobstructed.
- Check the condenser fan blades. Ensure they rotate freely within the fan orifices and are securely fastened to the fan motor shaft.
- Disable the compressor(s) by unplugging the reset relay for each circuit. Refer to the unit-wiring diagram that shipped with the unit.

NOTICE

Compressor Damage!

Excessive liquid accumulation in the suction lines could result in compressor damage.

Do not allow liquid refrigerant to enter the suction line.

- Verify that all compressor service valves, discharge service valves, and liquid line service valves are back seated on each circuit.
Important: COMPRESSOR SERVICE VALVES MUST BE FULLY OPENED BEFORE START-UP (SUCTION, DISCHARGE, AND LIQUID LINE).
Important: After liquid line service valves are fully opened (back seated), close just 1/4 turn to allow for fan pressure control (4S7, 4S8) operation.

- Check the compressor oil levels. Oil levels must be near or above the top of all compressor sight glasses.
- **Pack Stock Units:** Two low pressure switches are installed at the factory. However, only one is wired into the control circuit. This is to facilitate an EVP chiller or air over evaporator application. Before starting the system, verify that the correct pressure switch is connected to the control circuit. See Pressure Control Switch Settings table in Start-Up chapter for the pressure control settings, and the unit wiring diagram that shipped with the unit, for the appropriate connections.
- Check the condenser coils. They should be clean and the fins should be straight. Straighten any bent coil fins with an appropriate sized fin comb.
- Inspect the interior of the unit for tools and debris.

EVP Chiller Applications

- Flush building piping.

NOTICE

Heat Exchanger Damage!

Failure to follow instructions below could result in heat exchanger damage.

If an acidic commercial flushing solution is used, bypass the EVP chiller to prevent damage .

- Clean strainer. Make sure strainer blow down valve or plug is in place.
- Connect chiller. Make sure chiller 1/2"x14 NPTE plug is in place.
- Close drain valve
- Fill system with water.
- Vent system piping at the highest points.
- Inspect water piping for leaks and repair.

System Evacuation Procedures

NOTICE

Operating Under Vacuum!

Failure to follow these instructions will result in compressor failure.

Do not operate or apply power to the compressor while under a vacuum.

Each refrigeration circuit for split system applications must be evacuated before the unit can be started. Use a rotary type vacuum pump capable of pulling a vacuum of 100 microns or less. Verify that the unit disconnect switch and the system control circuit switches are "OFF".

The oil in the vacuum pump should be changed each time the pump is used with a high quality vacuum pump oil. Before using any oil, check the oil container for discoloration which usually indicates moisture in the oil and/or water droplets. Moisture in the oil adds to what the pump has to remove from the system, making the pump inefficient.

When connecting the vacuum pump to a refrigeration system, it is important to manifold the vacuum pump to both the high and low side of the system (liquid line access valve and suction line access valve). Follow pump manufacturer's directions for proper methods of using vacuum pump.

The lines used to connect pump to the system should be copper and the largest diameter that can practically be used. Using larger line sizes with minimum flow resistance can significantly reduce evacuation time. Rubber or synthetic hoses are not recommended for system evacuation. They have moisture absorbing characteristics which result in excessive rates of evaporation, causing pressure rise during standing vacuum test. This makes it impossible to determine if system has a leak, excessive residual moisture, or a continual or high rate of pressure increase due to hoses.

An electronic micron vacuum gauge should be installed in the common line ahead of the vacuum pump shutoff valve, as shown in , p. 95. Close Valves B and C, and open Valve A.

Start vacuum pump. After several minutes, the gauge reading will indicate the maximum vacuum the pump is capable of pulling. Rotary pumps should produce vacuums of 100 microns or less.

Open Valves B and C. Evacuate the system to a pressure of 300 microns or less. As vacuum is being pulled on the system, it may appear that no further vacuum is being obtained, yet the pressure is high. To facilitate the evacuation process, it is recommended that the vacuum be "Broken".

To break the vacuum, close valves A, B, & C and connect a refrigerant cylinder to the charging port on the manifold. Purge the air from the hose. Raise the standing vacuum pressure in the system to "zero" (0 psig) gauge pressure. Repeat this process two or three times during evacuation.

Note: It is unlawful to release refrigerant into the atmosphere. When service procedures require working with refrigerants, the service technician must comply with all Federal, State, and local laws.

Standing Vacuum Test

Once 300 microns or less is obtained, close Valve A and leave valves B and C open. This will allow the vacuum gauge to read the actual system pressure. Let the system equalize for approximately 15 minutes. This is referred to as a "standing vacuum test" where, time versus pressure rise. The maximum allowable rise over a 15 minute period is 200 microns. If the pressure rise is greater than 200 microns but levels off to a constant value, excessive moisture is present. If the pressure steadily continues to rise, a leak is indicated. Figure 68, p. 96 illustrates three possible results of the "standing vacuum test".

If a leak is encounter, repair the system and repeat the evacuation process until the recommended vacuum is obtained. Once the system has been evacuated, break the vacuum with refrigerant, and complete the remaining "Pre-Start Procedures" before starting the unit.

Figure 67. Typical vacuum pump hookup

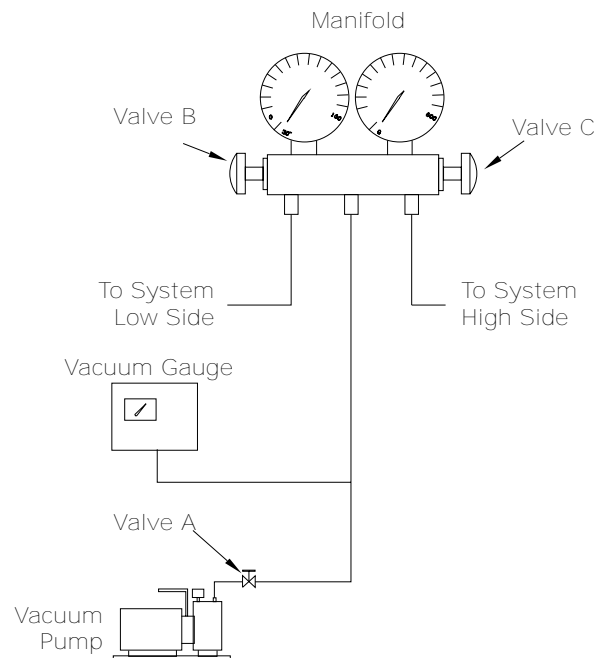
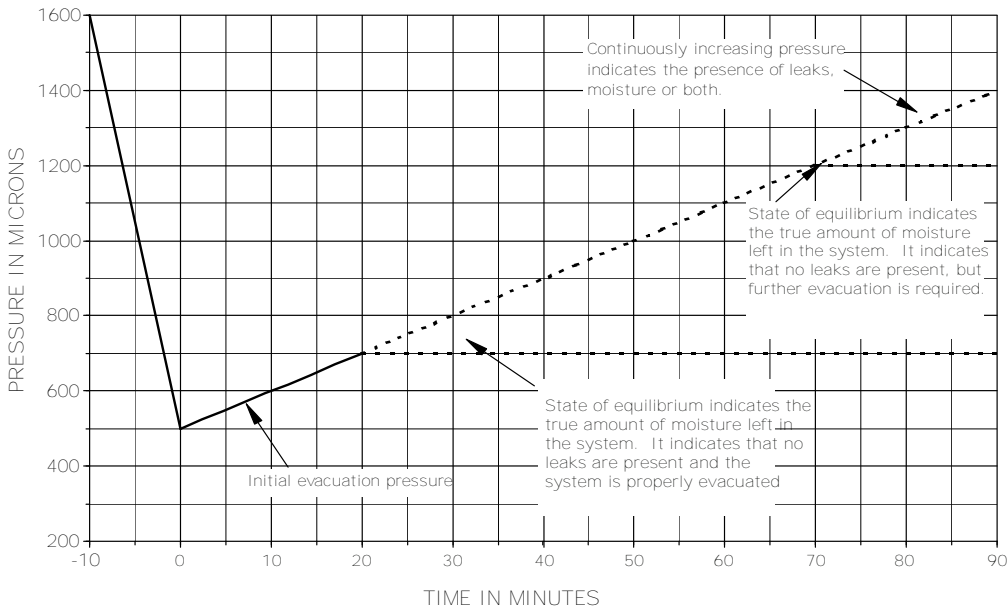

Figure 68. Evacuation time vs. pressure rise

Discharge Air Controller Checkout (Honeywell W7100A)

Note: The following checkout procedure must be performed in its entirety and in the sequence given.

⚠ WARNING

Hazardous Voltage!

Failure to disconnect power before servicing could result in death or serious injury.

Disconnect all electric power, including remote disconnects before servicing. Follow proper lockout/tagout procedures to ensure the power can not be inadvertently energized. Verify that no power is present with a voltmeter.

The W7100A (7U11) discharge air controller can be checked out using a highly accurate digital voltmeter and the W7100A accessory tool kit (Trane part # TOL-0101 or Honeywell part # 4074EDJ).

1. Turn all control switches to the "OFF" position to deactivate the Evaporator Fan and the Mechanical Cooling.
2. Turn the main power disconnect switch for the evaporator fan and condensing unit "OFF".
3. Disable the mechanical cooling by removing the field installed evaporator fan auxiliary interlock wire from terminal board 7TB5 terminal 3 inside the unit control panel.
4. At the Discharge Air Controller, in the unit control panel, remove the red dust cover from the test plug socket at the bottom of the W7100A. Insert the "Test Plug", from the kit, into the test plug socket.

The test plug overrides most of the built-in time delays for staging the compressors "On" and "Off". Refer to the illustration in Figure 69, p. 98 for terminal and control dial identification.

5. Install a jumper across the P and P1 terminals (remote setpoint input), and another jumper across terminals 6 and 7 (reset input) if reset is enabled.
 6. Disconnect the wires from terminals T and T1 (discharge air sensor).
 7. Remove the 3,400 ohm resistor (blue leads) from the test kit and connect it across terminals T and T1 to simulate a discharge air temperature of 60°F.
 8. Set the "Setpoint F" dial at 56°F or below; then set the "Control Band F" dial at 2 to minimize the control response time.
 9. At the Discharge Air controller, verify that the controller ground wire is connected to the chassis ground. Refer to the unit wiring diagram that shipped on the unit.
- Note:** It is not necessary to set the "Reset F" dial since the factory installed jumper across Terminals 6 and 7 disables this dial.
10. Turn the control circuit switch 1S2, in the unit control panel, and the main power disconnect switch for the condensing unit to the "ON" position.

After approximately 2 minutes (time required to drive the economizer fully open), the LEDs on the W7100 should begin to illuminate as the cooling outputs stage "On".

⚠ WARNING

Live Electrical Components!

Failure to follow all electrical safety precautions when exposed to live electrical components could result in death or serious injury.

When it is necessary to work with live electrical components, have a qualified licensed electrician or other individual who has been properly trained in handling live electrical components perform these tasks.

11. At the Discharge Air Controller, use a digital voltmeter to verify there is 24 volts AC across terminals TR & TR.
12. Set the "Setpoint F" dial at 64°F; within 10 seconds, the LEDs should turn "Off" as the cooling outputs stage "Off".
13. Immediately readjust the "Setpoint F" dial to 56°F; the LEDs should begin to illuminate again as the cooling outputs stage "On".
If the unit includes the zone reset option, proceed to the next step; if not, proceed to step 18.
14. Set the "Reset F" dial at 15°F and the "Setpoint F" dial at 41°F; then remove the jumper across terminals 6 & 7.
To simulate a call for maximum reset, install the 1780 ohm resistor (red leads), from the test kit, across terminals 6 and 7. The cooling LEDs should remain lit.
15. Turn the "Setpoint F" dial to 49°F; within 1 to 2 minutes, the LEDs should turn "Off" as the cooling outputs stage "Off".
16. As soon as all of the cooling LEDs are "Off", remove the 1780 ohm resistor from terminals 6 and 7 and re-install the jumper across these terminals.
17. Adjust the "Setpoint F" dial to 56°F; within 1 minute, the LEDs should illuminate as the cooling outputs stage "On".
If the system includes an economizer, complete steps 18 through 23 to verify proper economizer control operation; if not, proceed to step 24.
18. With all of the cooling LEDs "On", measure the DC voltage across terminals R (-) and W (+). The measured voltage should be 1.7 VDC to 2.1 VDC.
19. Set the "Setpoint F" dial at 64°F to drive the economizer output to the minimum position.
 - a. Within 2 minutes, the LEDs should turn "Off" as the cooling outputs stage "Off".
 - b. In approximately 5 minutes; measure the voltage across terminals R (-) & W (+). The measured voltage should drop to approximately 0.2 VDC.
20. Turn the control circuit switch 1S2, in the unit control panel, and the main power disconnect

switch to the "OFF" position.

21. Remove the wires from terminals R, B, W, & Y.
22. Measure the resistance across the following pairs of terminals, and compare the actual resistance readings with the values shown below.

W7100 Terminals	Resistance (ohms)
R-to-W	226
R-to-B	432
R-to-Y	226

23. Reconnect the economizer leads R, B, W, & Y to the appropriate terminals on the controller.
24. Turn the control circuit switch 1S2, in the unit control panel, and the main power disconnect switch to the "OFF" position.
25. Remove the jumper, installed in step 5, from terminals 6 & 7.
26. Remove the 3,400 ohm resistor from terminals T & T1 and reconnect the discharge air sensor leads to terminals T & T1.
27. Remove the "Test Plug" from the W7100 test socket and reinstall the red dust cover.
28. Reconnect the field installed evaporator fan auxiliary interlock wire to terminal board 7TB5 terminal 3.
29. Turn all control switches to the "On" position and restore main power to the system.

Figure 69. W7100A discharge air controller

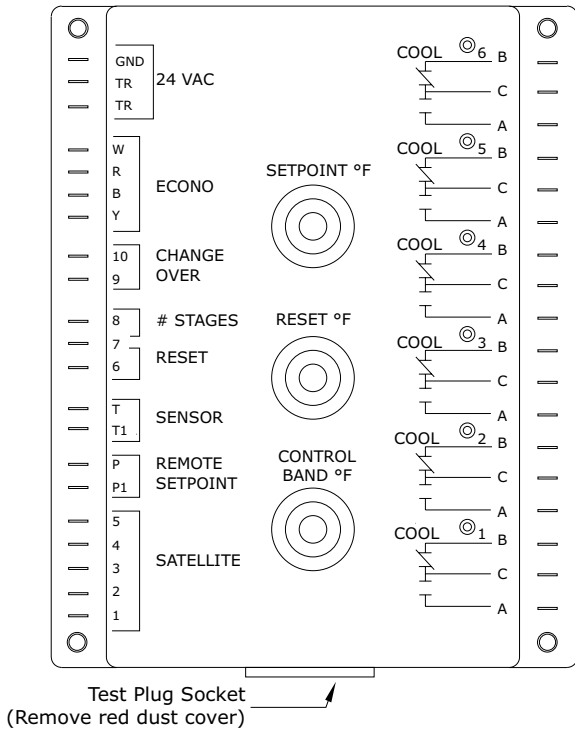

Discharge Air Sensor Checkout (Honeywell Sensor)

⚠ WARNING

Hazardous Voltage!
 Failure to disconnect power before servicing could result in death or serious injury.
 Disconnect all electric power, including remote disconnects before servicing. Follow proper lockout/tagout procedures to ensure the power can not be inadvertently energized. Verify that no power is present with a voltmeter.

1. Verify that the main power disconnect switch and the control circuit switch 1S2, in the unit control panel, is "OFF".
2. At the Discharge Air Controller, in the unit control panel, disconnect the wire connected to Terminal T1. Use a digital ohmmeter to measure the resistance across Terminal T and the wire removed from Terminal T1.
3. Use the conversion chart in [Figure 70, p. 98](#) to convert the measured resistance to an equivalent temperature.
4. Measure the actual temperature at the sensor location. If the measured resistance in step 2 is not within ± 10.0 ohms of the actual temperature, the sensor is out of range; replace it.
Note: Before condemning the sensor, verify that the connecting cable resistance is not excessive. Refer to the "Field Installed Control Wiring" section.
5. Make all necessary repairs and reconnect the duct sensor lead to terminal T1 on the controller.
6. Restore power to the system and turn all control switches to the "ON" position.

Figure 70. Discharge duct sensor 6RT2 & 6RT3 "temperature vs resistance" curve

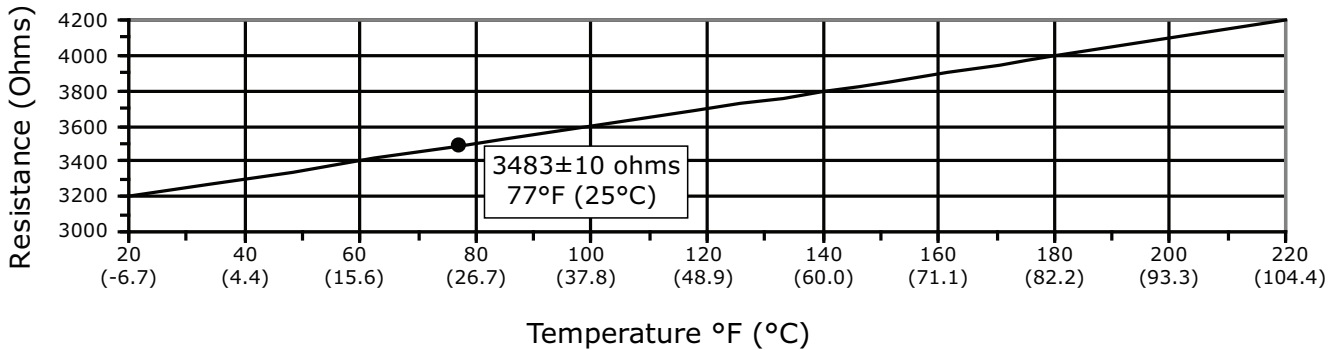

Economizer Actuator Checkout

(Used with "Zone" or "Discharge Air" Temp Controller)

The following procedures should be used to verify that the field provided economizer actuator(s) function properly. These procedures are based on using a typical Honeywell actuator. If another type actuator is

used, refer to the specific checkout procedures for that actuator.

⚠ WARNING

Hazardous Voltage!

Failure to disconnect power before servicing could result in death or serious injury.

Disconnect all electric power, including remote disconnects before servicing. Follow proper lockout/tagout procedures to ensure the power can not be inadvertently energized. Verify that no power is present with a voltmeter.

1. Turn all control switches to the "Off" position to deactivate the Evaporator Fan and the Mechanical Cooling. Verify that the main power disconnect switch for the condensing unit and the control circuit switch 1S2, in the unit control panel, is "OFF".
2. Verify that the field provided disconnect switch and/or the control circuit switch for the economizer actuator(s) is "OFF".
3. At the actuator, disconnect the control wires connected to Terminals W, R, B, and Y.
4. Install a jumper across the actuator terminals R-to-W-to-B.
5. Close the field provided disconnect switch and/or the control circuit switch for the economizer actuator(s). If the economizer actuator is working properly, it should drive to mid-position.
6. Open the field provided disconnect switch and/or the control circuit switch for the economizer actuator(s) and remove the jumpers installed in step 4.
7. Reconnect the control wires to the actuator terminals W, R, B, and Y.
8. Restore power to the actuator circuit and turn all control switches to the "ON" position and restore power to the system.

EVP Chiller Control Checkout (Honeywell W7100G)

Note: The following checkout procedure must be performed in its entirety and in the sequence given.

⚠ WARNING

Hazardous Voltage!

Failure to disconnect power before servicing could result in death or serious injury.

Disconnect all electric power, including remote disconnects before servicing. Follow proper lockout/tagout procedures to ensure the power can not be inadvertently energized. Verify that no power is present with a voltmeter.

The W7100G (6U11) chilled water controller can be checked out using a highly accurate digital voltmeter, the W7100 accessory tool kit (Trane part # TOL-0101 or Honeywell part # 4074EDJ), and the Honeywell 4074EFV resistor bag assembly.

1. Verify that the main power disconnect switch and the control circuit switch 1S2, in the unit control panel, is "OFF".
2. At the unit control panel, unplug the reset relay 1K11 and 1K12, (1K12 used on 40 through 60 Ton units only). Refer to the connection diagram that shipped with the unit for the location of the relay(s).
3. At the Chilled Water controller (6U11) inside the remote panel, disconnect the sensor (6RT2) leads from Terminals T & T1.
4. Remove the 3,400 ohm resistor (blue leads) from the test kit and connect it across Terminals T and T1 to simulate a discharge air temperature of 60°F.
5. Remove the factory-installed jumper (wire 209A) from the "fast response" Terminals 9 & 10.
6. To simulate a call for maximum reset, remove the jumper from Terminals 6 & 7 and install the 1780 ohm resistor (red leads), from the test kit, across Terminals 6 and 7.
7. Install a jumper across the P1 and P2 Terminals (remote setpoint input).
8. Remove the red dust cover from the test plug socket at the bottom of the W7100G. Insert the "Test Plug", from the kit, into the test plug socket. The test plug overrides most of the built-in time delays for staging the compressors "On" and "Off". Refer to the illustration in [Figure 71, p. 100](#) for terminal and control dial identification.
9. Set the "Reset F" dial at 20°F and the "Setpoint F" dial at 10°F
10. "Close" the main power disconnect switch and turn the control circuit switch 1S2, in the unit control panel, "ON".

⚠ WARNING

Live Electrical Components!
 Failure to follow all electrical safety precautions when exposed to live electrical components could result in death or serious injury.
 When it is necessary to work with live electrical components, have a qualified licensed electrician or other individual who has been properly trained in handling live electrical components perform these tasks.

11. At the Chilled Water Controller, use a digital voltmeter to verify there is 24 volts AC across terminals TR & TR.
12. After approximately 15 seconds, the LEDs on the W7100G should begin to illuminate as the cooling outputs stage "On".
13. Set the "Setpoint F" dial at 60°F; within 15 seconds, the LEDs should turn "Off" as the cooling outputs stage "Off".
14. Remove the 1780 ohm resistor from Terminals 6 & 7 and reinstall the wire jumper removed in step 6.
15. Set the "Setpoint F" dial at 50°F; within 15 seconds, the LEDs should turn "On" as the cooling outputs stage "On".
16. Turn the control circuit switch 1S2, in the unit control panel, to the "OFF" position.
17. Remove the 3,400 ohm resistor from Terminals T & T1 and reconnect the chilled water temperature sensor leads to Terminals T & T1.
18. Remove the "Test Plug" from the W7100G test socket and reinstall the red dust cover.
19. Plug the reset relay(s) 1K11 and 1k12 (if applicable) back into their receptacle.
20. Turn the control switch 1S2 to the "On" position to restore power to the control system.

Figure 71. W7100G chilled water controller

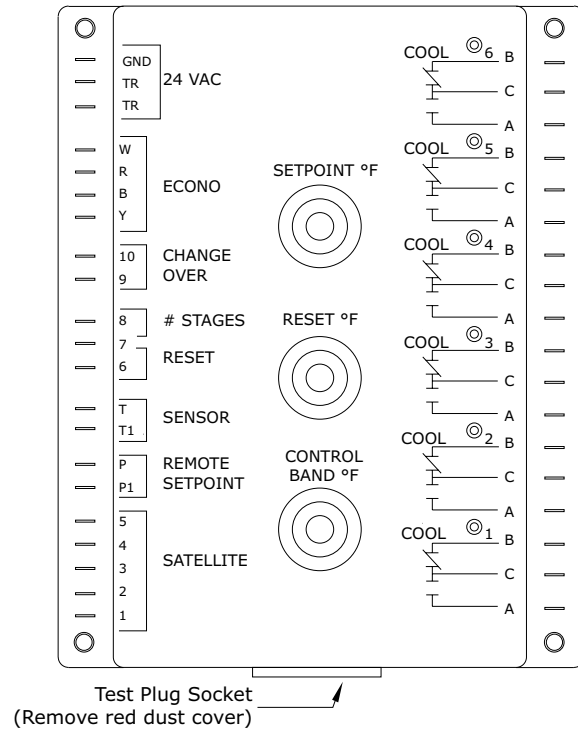

Chilled Water Sensor Checkout (Honeywell Sensor)

⚠ WARNING

Hazardous Voltage!
 Failure to disconnect power before servicing could result in death or serious injury.
 Disconnect all electric power, including remote disconnects before servicing. Follow proper lockout/tagout procedures to ensure the power can not be inadvertently energized. Verify that no power is present with a voltmeter.

1. Verify that the main power disconnect switch and the control circuit switch 1S2, in the unit control panel, is "OFF".
2. At the temperature controller, disconnect the wire connected to terminal T1. Use a digital ohmmeter to measure the resistance across terminal T and the wire removed from terminal T1.
3. Use the conversion chart in Figure 37 to convert the measured resistance to an equivalent temperature.
4. Measure the actual temperature at the sensor location. If the measured resistance in step 2 is not within ± 10.0 ohms of the actual temperature, the sensor is out of range; replace it.

Note: Before condemning the sensor, verify that the connecting cable resistance is not excessive. Refer to the "Field Installed Control Wiring" section.

5. Make all necessary repairs and reconnect the duct sensor lead to terminal T1 on the controller.
6. Turn all control switches to the "ON" position and restore power to the system.

Master Energy Control Checkout

Available Only For 20 - 60 Ton Units

⚠ WARNING

Hazardous Voltage!

Failure to disconnect power before servicing could result in death or serious injury.

Disconnect all electric power, including remote disconnects before servicing. Follow proper lockout/tagout procedures to ensure the power can not be inadvertently energized. Verify that no power is present with a voltmeter.

1. Open the system control switches 5S1 and 5S2 to disable the Evaporator Fan and Heating system.
2. Verify that the main power disconnect switch and the control circuit switch 1S2, in the unit control panel, is "OFF".
3. At the Master Energy Controller (7U11), in the unit control panel, remove at least one wire from each of the "Heat Relay" normally open contacts and one from each of the "Cool Relay" normally open contacts. Insulate the wires with tape to prevent shorting or grounding during control checkout.
4. Close the main power disconnect switch and turn the control circuit switch 1S2, in the unit control panel, "ON".

⚠ WARNING

Live Electrical Components!

Failure to follow all electrical safety precautions when exposed to live electrical components could result in death or serious injury.

When it is necessary to work with live electrical components, have a qualified licensed electrician or other individual who has been properly trained in handling live electrical components perform these tasks.

5. At the Master Energy Controller, use a digital voltmeter to verify that there is 20 volts DC power between terminals 1 (N) & 2 (+20). Refer to the illustration in Discharge Air Controller Checkout (Honeywell W7100A) section for terminal identification.

Note: The wires that are still connected to one side of the "Cool Relay" contacts, are active with 115 volts applied. Measuring the contacts when only one wire is connected will not cause any damage to the ohmmeter. However, do not try to ohm any set of contacts with wires connected to both terminals of that contact.

6. To verify the "Heating" output relays are operating;
 - a. place a jumper between Terminals 2 (+20) & 5 (H).
 - b. place the ohmmeter leads across each set of normally open "Heat Relay" contacts. The ohmmeter should read "Resistance" which indicates that the heating output relays have "pulled in".
7. To verify the "Cooling" output relays are operating;
 - a. Remove the jumper from Terminals 2 (+20) & 5 (H) and reinstall it between Terminals 2 (+20) & 4 (C).
 - b. Place the ohmmeter leads across each set of normally open "Cool Relay" contacts. The ohmmeter should read "Resistance" which indicates that the cooling output relays have "pulled in".
8. With all of the "Cooling Output" relays pulled in (step 7), measure the DC voltage across Terminals R (-) and W (+). The measured voltage should be approximately 1.7 to 2.1 VDC.
9. Remove the jumper installed between Terminals 2 (+20) & 4 (C).
10. Measure the voltage again across Terminals R (-) and W (+). The measured voltage should now be approximately 0.2 VDC.
11. Turn the control circuit switch 1S2, in the unit control panel, to the "OFF" position.
12. Remove the wires from Terminals R, B, W, & Y.
13. Measure the resistance across the following pairs of terminals and compare the actual resistance readings with the values shown below:

MEC Terminals	Resistance (ohms)
R-to-W	226
R-to-B	432
R-to-Y	226

14. Reconnect the economizer leads W, R, B and Y to the appropriate terminals on the controller.
15. Turn switches 1S2, 5S1, & 5S2 to the "ON" position to restore power to the control system.



Zone Thermostat Checkout (Honeywell T7067)

Available Only For 20 - 60 Ton Units

1. Open the system control switches 5S1 and 5S2 to disable the Evaporator Fan and Heating system.
2. Close the main power disconnect switch and turn control circuit switch 1S2, in unit control panel, "ON".

⚠ WARNING

Live Electrical Components!

Failure to follow all electrical safety precautions when exposed to live electrical components could result in death or serious injury.

When it is necessary to work with live electrical components, have a qualified licensed electrician or other individual who has been properly trained in handling live electrical components perform these tasks.

3. At the Zone Thermostat (6U37), use a digital voltmeter to verify that there is 20 volts DC power between thermostat Terminals 1 & 2. See illustration in Installation Electrical chapter, Thermostat Wiring section for terminal identification. Refer to [Table 29, p. 102](#) for the

thermostat "voltage output" ramps.

4. To check the "Cooling" output signal, place the voltmeter leads between thermostat Terminals 1 & 4. Refer to illustration in Installation Electrical chapter, Thermostat Wiring section and:
 - a. move the cooling (blue) setpoint lever from right to left. As the cooling setpoint is lowered, the voltage signal should increase and the "Cooling" LED brighten.
 - b. move the cooling (blue) setpoint lever from left to right. As the cooling setpoint rises, the voltage signal should decrease and the "Cooling" LED dim.
5. To check the "Heating" output signal, place the voltmeter leads between thermostat Terminals 1 & 5. Refer to illustration in Installation Electrical chapter, Thermostat Wiring section and:
 - a. move the heating (red) setpoint lever from left to right. As the heating setpoint rises, the voltage signal should increase and the "Heating" LED brighten.
 - b. move the heating (red) setpoint lever from right to left. As the heating setpoint lowers, the voltage signal should decrease and the "Heating" LED dim.

Table 29. Zone thermostat (6U37) "voltage output" ramps

1U11 Function	Nominal Operating Points and Throttling Ranges			Measured between 1U11 Terminals
	Pull-In Voltage ^(a) (VDC)	Drop-Out Voltage ^(a) (VDC)	Throttling Range	
HEAT 1 ^(a)	4.63	4.0		Terminal 5 (heating) & Terminal 1 (common)
HEAT 2 ^(a)	5.88	5.25		
HEAT 3 ^(a)	7.13	6.50		
HEAT 4 ^(a)	8.38	7.75		
COOL 1	4.58 - 5.42	3.44 - 4.56		Terminal 4 (cooling) & Terminal 1 (common)
COOL 2	5.43 - 6.34	4.69 - 5.81		
COOL 3	6.63 - 7.63	5.90 - 7.10		
COOL 4	7.84 - 8.92	7.11 - 8.39		
Economizer			2.75 - 4.00	

^(a) "Pull-In" and "Drop-Out" values are ± 0.25 VDC

Discharge Air Sensor Checkout (Honeywell 6RT1)

Available Only For 20 - 60 Ton Units

⚠ WARNING

Hazardous Voltage!

Failure to disconnect power before servicing could result in death or serious injury.

Disconnect all electric power, including remote disconnects before servicing. Follow proper lockout/tagout procedures to ensure the power can not be inadvertently energized. Verify that no power is present with a voltmeter.

1. Turn the control circuit switch 1S2, in the unit control panel, to the "OFF" position.
2. At the Master Energy Controller, disconnect wire connected to Terminal T1. Use a digital ohmmeter to measure resistance between Terminal T and the wire removed from Terminal T1.
3. Use chart in [Figure 72, p. 103](#) to convert the measured resistance to an equivalent temperature.
4. Measure the actual temperature at the sensor location. If the measured resistance in step 2 is not within ± 10.0 ohms of the actual temperature, the

6RT1 is out of range; replace it.

Note: Before condemning the sensor, verify that the connecting cable resistance is not excessive. Refer to the "Field Installed Control Wiring" section.

5. Make all necessary repairs and reconnect the duct sensor lead to terminal T1 on the controller.
6. Turn switches 1S2, 5S1, & 5S2 to the "ON" position to restore power to the control system.

Figure 72. 6RT1 discharge duct sensor "temperature vs resistance" curve

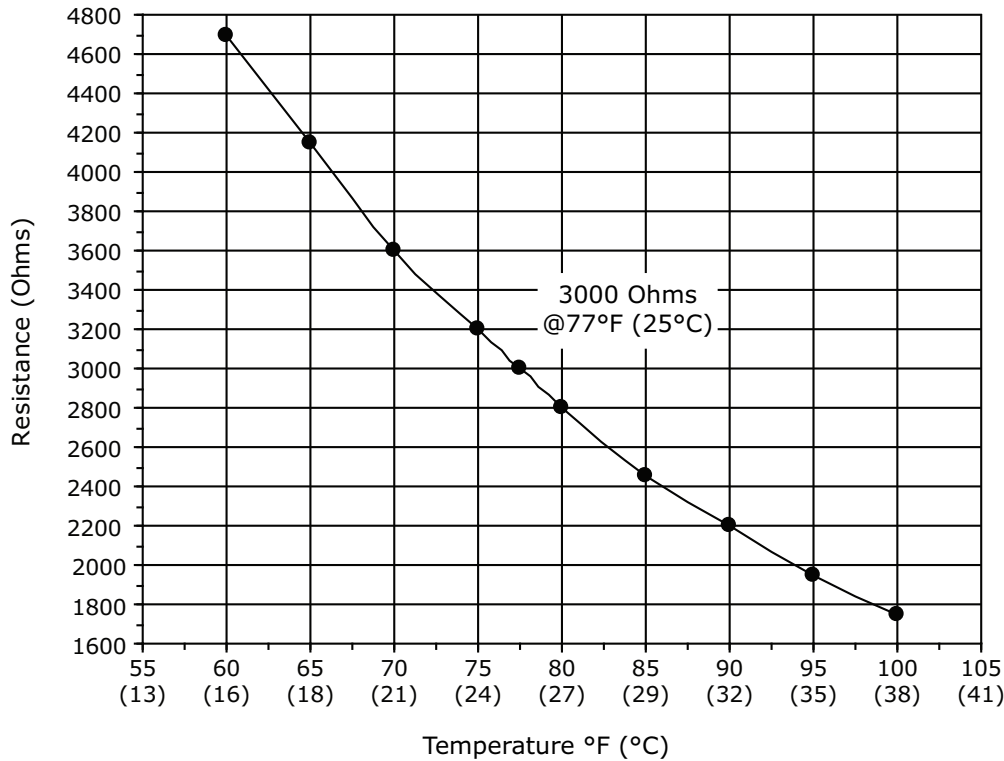
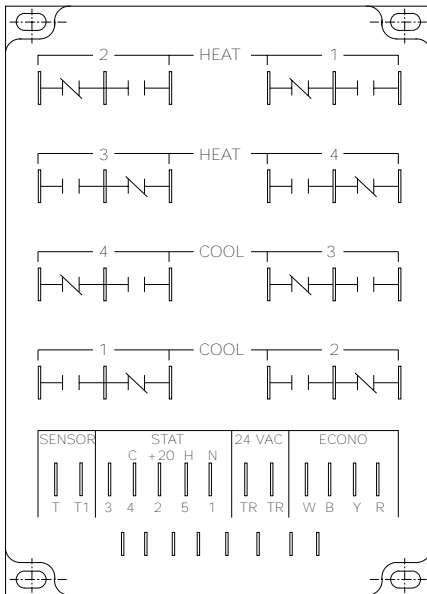

Figure 73. W973 master energy controller (MEC)

Voltage Imbalance

Excessive three phase voltage imbalance between phases will cause motors to overheat and eventually fail. The maximum allowable voltage imbalance is 2%. Measure and record the voltage between phases 1, 2, and 3 and calculate the amount of imbalance as follows:

% Voltage Imbalance = $100 \times [(AV - VD)/(AV)]$ where:

- AV (Average Voltage) = $(\text{Volt 1} + \text{Volt 2} + \text{Volt 3})/3$
- V1, V2, V3 = Line Voltage Readings
- VD = Line Voltage reading that deviates the farthest from the average voltage.

Example:

If voltage readings of supply power measured 221, 230, and 227, average volts would be:

- $AV = (221 + 230 + 227)/3 = 226 \text{ Avg.}$
- $VD = 221$

The percentage of imbalance is calculated as follows:

- $100 \times [(226 - 221)/226] = 2.2\%$

The 2.2% imbalance in this example exceeds the maximum allowable imbalance of 2.0%. This much imbalance between phases can equal as much as a 20% current imbalance with a resulting increase in motor winding temperatures that will decrease motor life. If the voltage imbalance is over 2%, notify the proper agencies to correct the voltage problem before operating this equipment.

Electrical Phasing

⚠ WARNING

Hazardous Voltage!

Failure to disconnect power before servicing could result in death or serious injury. Disconnect all electric power, including remote disconnects before servicing. Follow proper lockout/tagout procedures to ensure the power can not be inadvertently energized. Verify that no power is present with a voltmeter.

⚠ WARNING

Live Electrical Components!

Failure to follow all electrical safety precautions when exposed to live electrical components could result in death or serious injury.

When it is necessary to work with live electrical components, have a qualified licensed electrician or other individual who has been properly trained in handling live electrical components perform these tasks.

Proper electrical phasing can be quickly determined and corrected before starting unit by using an instrument such as Associated Research Model 45 Phase Sequence Indicator, following steps below

- Turn field supplied disconnect switch that provides power to terminal block 1TB1 to "Off" position
- Verify that the 115 volt control switch (1S2) in the unit control box is in the "Off" position.
- Connect the phase sequence indicator leads to the terminal block or to the "Line" side of the optional factory mounted disconnect switch as follows:
 - Black (phase A) to L1
 - Red (phase B) to L2
 - Yellow (phase C) to L3
- Close the main power disconnect switch or circuit protector switch that provides the supply power to the condensing unit.
- Observe the ABC and CBA phase indicator lights on the face of the sequencer. The ABC indicator light will glow if the phase is ABC. If the CBA indicator light glows, open the disconnect switch or circuit protection switch and reverse any two power wires.
- Restore the main electrical power and recheck the phasing.
- If the phasing is correct, open the main power disconnect switch or circuit protection switch and remove the phase sequence indicator.



Start-Up

Low Ambient Damper Adjustment (Factory or Field Installed)

When a unit is ordered with the low ambient option (model number digit 11 =1), a damper is factory installed over the lead condenser fan for each refrigeration circuit. See Component Location drawings in the Operating Principals chapter for damper location illustrations for the appropriate unit.

For field installation, mount the dampers over the condenser fans at the locations shown in Component Location drawings and connect the actuator, controller, and sensor for each circuit. (Refer to the Installation Instructions provided with each low ambient damper kit.)

The controller has a factory default setpoint of 80° F. This setpoint can be adjusted by installing a field supplied resistor on 2TB34 in the low ambient control panel located in the back of the main control panel. (See the low ambient wiring diagram that shipped with the unit or with the field kit, for resistance values and installation location.)

⚠ WARNING

Live Electrical Components!

Failure to follow all electrical safety precautions when exposed to live electrical components could result in death or serious injury.

When it is necessary to work with live electrical components, have a qualified licensed electrician or other individual who has been properly trained in handling live electrical components perform these tasks.

Inspect the damper blades for proper alignment and operation. Dampers should be in the closed position during the "Off" cycle.

NOTICE

Actuator Damage!

Do not depress actuator clutch while actuator is energized as it could result in actuator damage.

If adjustment is required:

1. Remove the sensor leads from the input terminals 6 and 7 for circuit #1 and/or 11 and 12 for circuit #2. (Controller output signal will go to 0.0 VDC and the damper will drive to the closed position.)
2. Loosen the actuator clamp.
3. Firmly hold the damper blades in the closed position
4. Retighten the actuator clamp.

To check damper operation, jumper between the sensor input terminals 6 and 7 and/or 11 and 12 (if applicable). Controller output signal will go to 10 VDC and damper will drive to full open position.

EVP Chiller Applications

Start the chilled water circulating pump by closing the field provided pump disconnect switch and turn the pump control circuit switch 5S1 "On".

Check the flow device to ensure it opens at minimum flow and closes properly.

With water circulating through the system, check the EVP chiller pressure drop and adjust the flow (if necessary). Refer to the appropriate EVP chiller size in for the operating pressure drop.

Freezestat Setting

At the remote panel, set the freezestat at a minimum of 5°F above the chilled water freezing temperature.

"Air Over" Evaporator Application

⚠ WARNING

Hazardous Voltage!

Failure to disconnect power before servicing could result in death or serious injury.

Disconnect all electric power, including remote disconnects before servicing. Follow proper lockout/tagout procedures to ensure the power can not be inadvertently energized. Verify that no power is present with a voltmeter.

Verifying Proper Supply Fan Rotation

1. Verify the main power disconnect switch is off.
2. Unplug 1K21 & 1K22 reset relays from sockets in the unit main control box to prevent inadvertent compressor starts.
3. Ensure that the "System" selection switch at the remote panel is in the "Off" position and the "Fan" selection switch for the appropriate controls application is in the "Auto" position. (VAV units do not utilize a "Fan" selection input.)



⚠ WARNING

Live Electrical Components!

Failure to follow all electrical safety precautions when exposed to live electrical components could result in death or serious injury.

When it is necessary to work with live electrical components, have a qualified licensed electrician or other individual who has been properly trained in handling live electrical components perform these tasks.

4. Turn the 115 volt control circuit switch 1S2 to the "On" position.
5. Turn the main power disconnect switch or circuit protector switch for the unit to the "On" position.

⚠ WARNING

Rotating Components!

Failure to disconnect power before servicing could result in rotating components cutting and slashing technician which could result in death or serious injury.

Disconnect all electric power, including remote disconnects before servicing. Follow proper lockout/tagout procedures to ensure the power can not be inadvertently energized.

6. Turn the field provided disconnect switch for the supply fan to the "On" position and "bump" the field supplied control circuit switch "On", (i.e., "On" then immediately "Off").
7. If the fan does not start in applications where the fan control circuit is energized via terminal 7TB5-1 in the RAUJ 115V control circuit, the field power wiring to the RAUJ unit could be improperly phased. Phase protection module (1U3) located in the RAUJ control box interrupts control circuit power when improperly phased field power is detected.
8. While the fan is coasting down, check the rotation. If the fan is rotating backwards, turn the field provided disconnect switch for the air handler to the "Off" position and interchange any two of the main power wires at the fan motor starter or contactor.
9. After all adjustments have been made, restart the supply fan and proceed through the following procedures.

System Airflow Measurement

Much of the systems performance and reliability is closely associated with, and dependent upon having the proper airflow supplied both to the space that is being conditioned and across the evaporator coil.

Measuring Airflow

With the supply fan rotating in the proper direction, measure the amperage at the supply fan contactor. If the amperage exceeds the motor nameplate value, the static pressure is less than design and the airflow is too high. If the amperage is below the motor nameplate value, static pressure could be too high and CFM could be too low. To determine the actual CFM ($\pm 5\%$);

1. Measure the actual fan RPM
2. Calculate the Theoretical BHP:
$$\text{BHP} = \frac{\text{Actual Motor Amps} \times \text{Motor HP}}{\text{Motor Nameplate Amps}}$$
3. Plot this data onto the appropriate Fan Performance Curve or Performance Table that shipped with the Air Handling equipment. Where the two points intersect, read the CFM line.

Use this data to assist in calculating a new fan drive if the CFM is not at design specifications.

Alternate Method

An alternate method with less accuracy is to measure the static pressure drop across the evaporator coil. This can be accomplished by the following steps.

1. Drill a small hole through the unit casing on each side of the coil.

NOTICE

Coil Damage!

Failure to follow instructions could result in coil damage.

When drilling holes in this area, take care to avoid damaging coil.

2. Measure the difference between the pressures at both locations.
3. Plot this value onto the appropriate component pressure drop curve that shipped with the Air Handling equipment. Use the data to assist in calculating a new fan drive if the CFM is not at design specifications.
4. Plug the holes after the proper CFM has been established.

After all adjustments have been made, proceed through the following procedures.

Preliminary Expansion Valve Adjustment

NOTICE

Compressor Damage!

Failure to follow instructions could result in compressor failure or reduced compressor life. Increase thermal expansion valve superheat settings before starting compressors to minimize compressor operation with low oil viscosity.

No bleed thermal expansion valves are set by manufacturers to control between 12-14.4°F superheat

leaving the evaporator at nominal design conditions. Thermal expansion valves with bleeds are set to their highest superheat setting. Actual superheat depends on many factors (valve vs. system relative sizing, operating conditions, system load step, system charge, piping, and condenser fan control). The thermal expansion valves must be adjusted as part of the unit start-up procedure. Do not adjust valves beyond manufacturer's available nominal adjustment range.

Note: In tables below, valve part numbers with “-ZGA” in place of “-GA”, may be used interchangeably. “ERZE-” part number valves are an acceptable alternate to “BBIZE” valves.

Table 30. Thermal expansion valve manufacturer settings - no bleed — Sporlan

Standard off the shelf nominal valve settings (90 PSIG air test setting)						
Valve	Superheat, °F	CW turns available	CCW turns available	Superheat change per turn	Field adjust for 18°F (DX evap coil)	Field adjust for 15°F (EVP only)
BBIZE-1-GA	12	4.5	4.5	2.4°F	2.5 CW	—
BBIZE-1-1/2-GA						
BBIZE-2-GA						
BBIZE-3-GA						
BBIZE-4-GA						
BBIZE-5-GA						
BBIZE-6-GA						
BBIZE-8-GA						
BBIZE-12.5-GA						
BBIZE-15-GA						
OZE-20-GA						
OZE-25-GA						
OZE-35-GA						
OZE-50-GA						
OZE-60-GA		7.5		1.8°F	3.25 CW	1.75 CW

Table 31. Thermal expansion valve manufacturer settings - no bleed — Emerson

Standard off the shelf nominal valve settings							
Valve	Nom Tons	Superheat, °F	CW turns available	CCW turns available	Superheat change per turn	Field adjust for 18°F (DX evap coil)	Field adjust for 15°F (EVP only)
C	1-1/2 to 7	13	6	6	4	1.25 CW	
TF	12 to 20		5	5	2	2.5 CW	1.0 CW



Start-Up

Table 32. Thermal expansion valve manufacturer settings - no bleed — Danfoss

Standard off the shelf nominal valve settings									
Valve	Body size	SHT, °F	CW turns available	CCW turns available	Superheat change per turn	Field adjust for 18°F (DX evap coil)	Field adjust for 15°F (EVP only)		
TGEL 3.5 TR	TGE 10	14.4	4	3	4.5°F	.75 CW	—		
TGEL 4.5 TR									
TGEL 6.5 TR									
TGEL 9 TR									
TGEL 13 TR									
TGEL 15 TR	TGE 20		14.4	7	4	3	1.25 CW	.25 CW	
TGEL 19 TR									
TGEL 23 TR									
TGEL 31 TR	TGE 40			14.4	7	4	3	1.25 CW	.25 CW
TGEL 35 TR									
TGEL 46 TR									

Information in tables above is approximate and intended to simplify field adjustment by presetting valves to approximately 18°F superheat for DX evap coils and 15°F superheat for EVP chillers. Actual operating superheat will typically be less than 18°/15°F and varies depending on many factors including those listed above. Superheat gradient (superheat change per turn) is also approximate and will not be constant throughout the valve adjustment range. Check superheat after startup to confirm proper control.

Tag or mark valve to keep a record of any field adjustments.

Adding Preliminary Charge

1. Leak check must be completed and system evacuated.
2. Verify that oil levels are near or above the top of all compressor sight glasses.

⚠ WARNING

Hazardous Voltage!
 Failure to disconnect power before servicing could result in death or serious injury.
 Disconnect all electric power, including remote disconnects before servicing. Follow proper lockout/tagout procedures to ensure the power can not be inadvertently energized. Verify that no power is present with a voltmeter.

3. Insure field supplied unit disconnect is "OFF". Then verify that the unit 1S2 115 volt control circuit switch is "OFF" and that reset relays 1K21 & 1K22 have been unplugged to prevent inadvertent compressor starts.

4. Turn field supplied unit disconnect "ON" to energize crankcase heaters. Verify crankcase heaters are operating.
5. Verify that discharge, suction, and liquid line service valves are open. Liquid line service valve must be closed 1/4" turn from full open to allow for fan pressure switch operation.
6. If system is equipped with hot gas bypass, insure hot gas bypass is closed and remains closed during charging.
7. Refer to table below for the charge estimate for the condensing unit circuit and piping at the appropriate piping length.

Table 33. Recommended maximum charge per circuit (lbs)—condensing unit and lines only (does not include evaporator)

Unit Size	Total Interconnecting Line Length (ft)		
	50	100	150
20	19	25	32
25	25	37	50
30	25	38	50
40	25	37	50
50	25	38	50
60	24	36	48
80	49	69	88
100	52	73	94
120	55	76	98

NOTICE

Compressor Damage!

Excessive liquid accumulation in the suction lines could result in compressor damage. Do not allow liquid refrigerant to enter the suction line.

8. At the liquid line angle valve add as much R-410A LIQUID as possible up to, but not exceeding, that listed in [Table 33, p. 108](#). Depending on conditions, it could not be possible to add more than 60% of the charge listed in the table. This will be adequate for compressor startup. More charge will be added after compressors are started. Use an accurate scale to measure and record the preliminary amount of R-410A added to each circuit.
9. Do not add refrigerant in the suction line at this time to prevent excessive refrigerant in the low side prior to compressor startup.

Compressor Start-Up (All Systems)

Table 34. Minimum starting ambient temperature

Unit Size	Minimum Starting Ambient ^(a) (°F)			
	Standard Units		Low Ambient Units	
	With HGBP	No HGBP	With HGBP	No HGBP
20-60	45	40	10	0
80-120	45	40	10	0

^(a) Minimum starting ambients in degrees F and is based on the unit operating at minimum step of unloading and 5 mph wind across condenser.

1. Review "Adding Preliminary Charge" section and confirm all steps were completed.

NOTICE

Compressor Damage!

Failure to follow instructions could result in compressor damage. Keep crankcase heaters on whenever refrigerant is in the system. If crankcase heaters have not been on with refrigerant in the system, turn the crankcase heaters on for a minimum of 24 hours before starting compressors.

Note: Initial compressor start-up is best done above 70°F outdoor temperature with ample evaporator load (at least 70°F return air and 350 CFM/Ton)

Note: [Table 34, p. 109](#) gives the minimum starting temperatures for both "Standard" & "Low" Ambient units

Important: Do not attempt to charge the system with the low ambient dampers and/or hot gas bypass operating (if applicable). Disable low ambient dampers in the "Open" position (refer to the "Low Ambient Damper Adjustment" section) and verify hot gas bypass is not operating before proceeding.

2. On units with dual circuits, work on only one circuit at a time. See tables in Compressor Sequencing section for the compressor sequencing and Operating Principals chapter Component Location illustrations for their location..
3. Compare the amount of preliminary charge added in the proceeding section to the table in that section for condensing unit and piping only. Up to 20% more charge than listed in that table may be required to fully charge the circuit, depending on the evaporator design. Have adequate R-410A available to complete charging as described in the following steps.
4. Attach a thermocouple type temperature sensor on the liquid line close to the liquid line service valve. To insure an accurate liquid temperature reading, clean the line where the sensor is attached. After securing the sensor to the line, insulate the sensor and line to isolate it from the ambient air.
5. Attach a set of service gauges onto the suction and discharge gauge ports.
6. Check the low side pressure. The low pressure cutout (4S3, 4S4) opens below 58 psig and closes above 78 psig. If the low side pressure is less than 78 psig, refrigerant may need to be added to the suction line before starting the compressor(s). Slowly meter into the suction line only as much R-410A as needed to make the low pressure cutout from the VAPOR charging connection. If possible, plan to use this entire refrigerant bottle on the same unit in order to minimize fractionalization. Use an accurate scale to measure and record the amount of R-410A added.

⚠ WARNING

Hazardous Voltage!

Failure to disconnect power before servicing could result in death or serious injury. Disconnect all electric power, including remote disconnects before servicing. Follow proper lockout/tagout procedures to ensure the power can not be inadvertently energized. Verify that no power is present with a voltmeter.

7. Switch the field supplied unit disconnect "OFF". Open the unit control box and plug in the reset relay (1K21 or 1K22) for the circuit being started only.
8. This charging procedure is more accurate at higher

outdoor temperatures. If the outdoor temperature is less than 80°F, temporarily disable the fan pressure control switches (4S11, 4S12) or (4S7, 4S8) on 80 - 120 Ton units. To do this, refer to unit wiring diagrams and disconnect the wires between the switches and the terminal strip.

9. Switch the RAUJ 115 volt (1S2) control circuit switch "ON". Close the control box and then switch the field supplied unit disconnect "ON". Unit power should be off no longer than 30 minutes to prevent refrigerant migration to compressor sumps. If power is off for longer than 30 minutes, allow time for crankcase heaters to drive refrigerant from compressor sumps before starting compressors.

NOTICE

Compressor Damage!

Failure to follow instructions could result in compressor damage.

Keep crankcase heaters on whenever refrigerant is in the system.

If crankcase heaters have not been on with refrigerant in the system, turn the crankcase heaters on for a minimum of 24 hours before starting compressors.

10. Verify that oil levels are near or above the top of all compressor sight glasses.

⚠ WARNING

Live Electrical Components!

Failure to follow all electrical safety precautions when exposed to live electrical components could result in death or serious injury.

When it is necessary to work with live electrical components, have a qualified licensed electrician or other individual who has been properly trained in handling live electrical components perform these tasks.

NOTICE

Compressor Damage!

Failure to follow instructions below could result in compressor damage.

Improper power phasing will cause compressor to run backwards. Compressor could be running backwards if it is noisy, low side shell gets hot, suction pressure does not drop within 5 seconds after startup, and compressor only draws ½ expected amps. Stop the compressor immediately and have a qualified electrician or technician properly trained in 3 phase power correct the wiring.

11. Start the first step compressor only.
 - a. If the compressor and condenser fans do not start, the field power wiring to the RAUJ unit

could be improperly phased. A main unit power phase protection module (1U3) is located in the RAUJ control box and interrupts control circuit power when improperly phased field power is detected.

- CSHD compressors (used in 20 to 60 ton units) are not equipped with electronic modules and do not have individual compressor phase protection.
- CSHN compressors (used in 80 to 120 ton units) are individually equipped with compressor protection modules (381U1, 382U2, 383U3, 384U4, 385U5, 386U6) located in the compressor junction boxes. These modules include phase, voltage, overcurrent, and over temperature protection. If CSHN compressors are started with reversed phasing, the module output relay will open in about 6 seconds. Module output relays are wired in series with the unit 115 volt control circuit reset relays (1K21, 1K22). When any module output relay opens, the circuit reset relay latches closed and circuit operation is locked out. Note: Refer to the Service & Maintenance section of this manual or COM-SVN01*-EN for further discussion regarding other potential compressor protection module faults.

- b. As soon as a compressor starts, verify correct rotation. If a scroll compressor is allowed to run backwards for even a very short period of time, internal compressor damage could occur and compressor life could be reduced. When rotating backwards scroll compressors make a loud noise, do not pump, draw about 1/2 expected amps, and the low side shell gets hot. Immediately shut off a compressor rotating backwards.
- c. Check condenser fans for proper rotation. As viewed from the top of the unit, the correct rotation direction is clockwise.
- d. If some or all of the fans are rotating backward, follow steps outlined in Motors Rotating Backwards section. Once complete, continue steps below.
- e. Start the remaining circuit compressor(s). Verify correct rotation. Incorrect rotation is noisy, compressor draws about ½ expected amps, and the low side shell gets hot. Immediately shut off any compressors rotating backwards.
- f. After allowing 10 minutes for circuit operation to stabilize at full load, check the liquid temperature and discharge pressure. Plot on [Figure 74, p. 112](#). Expect the operating point to be in the "Add charge" portion of the chart. The remainder of the circuit charge will be added in the following steps.

- g. Subtract the total charge already added from the table in Preliminary Charging section charge estimate for condensing unit at the appropriate piping length. Add no more R-410A than 1/2 of this difference at a time.
- h. With all the circuit compressors operating, SLOWLY meter R-410A into the suction line from the LIQUID charging connection. Add no more than 1/2 of the difference from Step 11g above. Then allow the unit to run for 10 minutes, and plot the new operating point on Figure 74, p. 112. Use an accurate scale to measure and record the amount of R-410A added.
- i. Repeat Step 11h, adding smaller increments of refrigerant until circuit operation is approximately on the appropriate line of Figure 74, p. 112. As the charging line is approached, smaller increments of refrigerant will move the operating point more.

Note: *This procedure results in less subcooling than previous split system charging methods. Note that using this charging method will at times result in bubbles at sight glasses installed just upstream of expansion valves; especially during lower ambient operation, part load, and for systems with evaporators located above condensing units. This charging procedure will maximize the usable operating envelope of the R-410A RAUJ units.*

Important: *Do not release refrigerant to the atmosphere! If adding or removing refrigerant is required, the service technician must comply with all Federal, State, and local laws. Refer to general service bulletin MSCU-SB-1 (latest edition).*

- j. Record the total charge added to the circuit.
 - k. If applicable, repeat steps Step 11a through Step 11j on the second refrigeration circuit.
 - l. If in Step 8. the fan pressure control switches were disabled to allow for charging below 80°F outdoor temperature, disconnect unit power and reconnect the control wiring for these fans at this time. Follow the procedures discussed earlier to confirm proper rotation of these condenser fans.
12. After the unit has been operating for approximately 30 minutes at full load with all condenser fans running, record the operating pressures. Operating pressures should be within +/- 10 Psig of the appropriate pressure curve in Figure 74, p. 112. Measure and record the system subcooling and superheat as described in the following sections.
 13. Verify that the oil level in each compressor is correct. As a minimum, oil must be visible in the sight glass.
 14. Once the checks and adjustments for the operating circuit has been completed, check and record the following data on the maintenance log shown at the end of the chapter. Repeat these procedures for the second refrigeration circuit, if applicable.
 - ambient temperature;
 - compressor oil level (each circuit);
 - compressor suction and discharge pressures and liquid line temperatures (each circuit);
 - superheat and subcooling (each circuit);
 15. Turn the 115-volt control circuit switch 1S2 to the "OFF" position and open the field provided or optional factory mounted disconnect switch.
 16. After shutting the system off, check the compressor oil appearance. Discoloration of the oil indicates that an abnormal condition has occurred.
 - a. If the oil is dark and smells burnt, it has overheated because of: compressor operating at extremely high condensing temperatures; high superheat; a compressor mechanical failure; or, occurrence of a motor burnout.
 - b. If the oil is black and contains metal flakes, a mechanical failure has occurred. This symptom is often accompanied by a high compressor amperage draw.
 - c. If a motor burnout is suspected, use an acid test kit to check the condition of the oil. Test results will indicate an acid level exceeding 0.05 mg KOH/g if a burnout occurred.

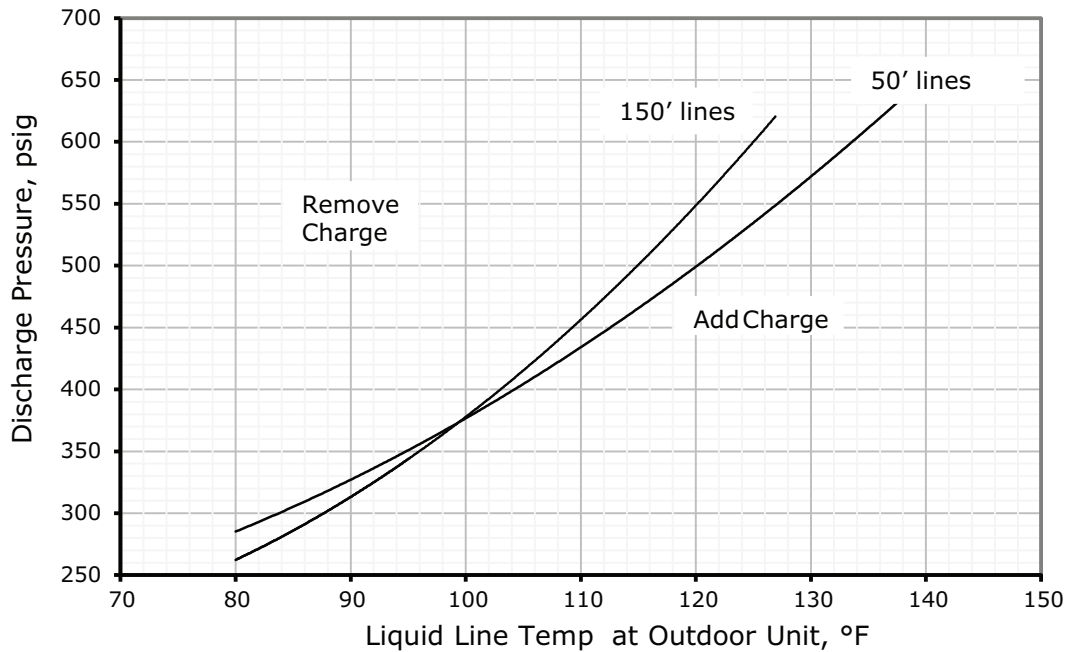
Figure 74. System charging chart (all units)

Motors Rotating Backward

If, during startup steps above, some or all of the condenser motors are rotating backward, follow the steps below.

- If all motors are rotating backward, see All Motors are Rotating Backward section.
- If some, but not all motors are rotating backward, see Some Motors are Rotating Backward section.
-

⚠ WARNING

Rotating Components!

Failure to disconnect power before servicing could result in rotating components cutting and slashing technician which could result in death or serious injury.

Disconnect all electric power, including remote disconnects before servicing. Follow proper lockout/tagout procedures to ensure the power can not be inadvertently energized.

⚠ WARNING

Hazardous Voltage!

Failure to disconnect power before servicing could result in death or serious injury.

Disconnect all electric power, including remote disconnects before servicing. Follow proper lockout/tagout procedures to ensure the power can not be inadvertently energized. Verify that no power is present with a voltmeter.

All Motors are Rotating Backward

1. Turn the field supplied disconnect switch or circuit protector switch that provides power to the condensing unit to the "Off" position. Lock the disconnect switch in the open position while working at the unit.
2. Verify that field connected main power phase sequence matches that specified on the unit wiring diagrams. Rotation will be incorrect if any two power wires are interchanged at the unit terminal block 1TB1 or the optional factory mounted non-fused disconnect switch (1S1) in the unit control panel.
3. Check the unit phase module (1U1) for correct operation and unit wiring.

Note: Interchanging "Load" side power wires at the contactors only affects the individual fan rotation. Ensure that the voltage phase sequence at the main terminal block 1TB1 is ABC as outlined in the "Electrical Phasing" section.

Some Motors are Rotating Backward

1. Turn the field supplied disconnect switch or circuit protector switch that provides power to the condensing unit to the "Off" position. Lock the disconnect switch in the open position while working at the unit.
2. If the unit main power phase sequence is correct, rotation of an individual motor will be backwards if any two leads are interchanged between the unit main power and the motor. Verify that wiring from the unit main power to the motor is per the unit wiring diagram. Refer to the illustration in Figure 63 for the compressor terminal/phase identification. Compressor damage could occur if a compressor runs backwards for a very short period of time.

Subcooling

The outdoor ambient temperature must be between 65°F and 105°F and the relative humidity of the air entering the evaporator must be above 40 percent. When the temperatures are outside of these ranges, measuring the operating pressures can be meaningless.

With the unit operating at "Full Circuit Capacity", acceptable subcooling ranges between 8°F to 16°F.

Measuring Subcooling

Note: System charging is done by using the System Charging Chart. Do not attempt to charge the system based on subcooling.

- At the liquid line service valve, measure the liquid line pressure. Using a Refrigerant R-410A pressure/temperature chart, convert the pressure reading into the corresponding saturated temperature.
- Measure the actual liquid line temperature as close to the liquid line service valve as possible. To ensure an accurate reading, clean the line thoroughly where the temperature sensor will be attached. After securing the sensor to the line, insulate the sensor and line to isolate it from the ambient air.

Note: Glass thermometers do not have sufficient contact area to give an accurate reading.

- Determine the system subcooling by subtracting the actual liquid line temperature from the saturated liquid temperature.

Measuring Superheat

- Measure the suction pressure at the outlet of the evaporator as close to the expansion valve bulb location as possible.
- Measure the suction line temperature as close to the expansion valve bulb, as possible.
- Using a Refrigerant/Temperature chart, convert the pressure reading to a corresponding saturated vapor temperature.

Note: On many Trane fan/coil units, an access valve is provided close to the expansion valve bulb location. This valve must be added on climate changers and other evaporators.

- Subtract the saturated vapor temperature, from the actual suction line temperature. The difference between the two temperatures is known as "superheat".

Compressor Oil

NOTICE

Compressor Damage!

POE oil is hygroscopic – it absorbs water directly from the air. This water is nearly impossible to remove from the compressor oil and can result in compressor failures.

To prevent POE oil from absorbing water, the system should not remain open for longer than necessary. When open, dry nitrogen should flow through the piping. Only new oil containers should be used for service and maintenance. Always use the smallest container size required for the job requirements. Always leave the oil container tightly sealed until time of use. Do not reuse oil that has been opened.

RAUJ unit and replacement compressors ship fully charged with POE oil from the factory. The scroll compressor uses POE oil (OIL00079 for a quart container or OIL00080 for a gallon container) without substitution. The appropriate oil charge for a 7.5 Ton scroll compressor is 6.3 pints. For 9 through 15 Ton light commercial scroll compressors is 7 pints. For a 15 and 20 Ton large commercial scroll compressors (80 to 120 ton units), use 14.2 pints.

Compressor Crankcase Heaters

Table 35. Heater information

Compressor Configuration and Size	Heater (watt)	Quantity (per compressor)
CSHD 7.5 to 15 tons	90	1
CSHN 15 to 20 tons	160	1



Start-Up

Table 36. Pressure control switch settings (psi)

Pressure Switch	Make	Break
Hi Pressure	550	650
Lo Pressure	78	58
Condenser Fan Cycling switch	444	255
EVP Lo Pressure	105	82

Compressor Sequencing

Table 37. Compressor sequence: 20-120 Ton units

Unit Size	Control Step	Circuit 1	Circuit 2	% Loaded Unit
20	1	1A	—	50
	2	1A, 1B	—	100
25	1	1A	—	42
	2	1A, 1B	—	100
30	1	1A	—	50
	2	1A, 1B	—	100
40	1	1A	-	25
	2	1A	2A	50
	3	1A, 1B	2A	75
	4	1A, 1B	2A, 2B	100
50	1	1A	—	23
	2	1A	2A	46
	3	1A, 1B	2A	73
	4	1A, 1B	2A, 2B	100
60	1	1A	—	25
	2	1A	2A	50
	3	1A, 1B	2A	75
	4	1A, 1B	2A, 2B	100
80	1	1A	—	17
	2	1A	2A	33
	3	1A, 1B	2A	50
	4	1A, 1B	2A, 2B	66
	5	1A, 1B, 1C	2A, 2B	83
	6	1A, 1B, 1C	2A, 2B, 2C	100

Table 37. Compressor sequence: 20-120 Ton units (continued)

Unit Size	Control Step	Circuit 1	Circuit 2	% Loaded Unit
100	1	1A	—	15
	2	1A	2A	30
	3	1A, 1B	2A	45
	4	1A, 1B	2A, 2B	60
	5	1A, 1B, 1C	2A, 2B	80
	6	1A, 1B, 1C	2A, 2B, 2C	100
120	1	1A	—	17
	2	1A	2A	33
	3	1A, 1B	2A	50
	4	1A, 1B	2A, 2B	66
	5	1A, 1B, 1C	2A, 2B	83
	6	1A, 1B, 1C	2A, 2B, 2C	100

Pressure Curves

Note: For the following curves, all compressors and condenser fans are running.

To check operating pressures:

1. Start the unit and allow the pressures to stabilize.
2. Measure the outdoor air dry bulb temperature (F) entering the condenser coil.
3. Measure the discharge and suction pressure (psig) next to the compressor.
4. Plot the outdoor dry bulb temperature and the operating suction pressure (psig) onto the chart.
5. At point of intersection, read to the left for discharge pressure. Measured discharge pressure should be within +/- 10 psig of graph.

Figure 75. 20 Ton cooling cycle pressure curve

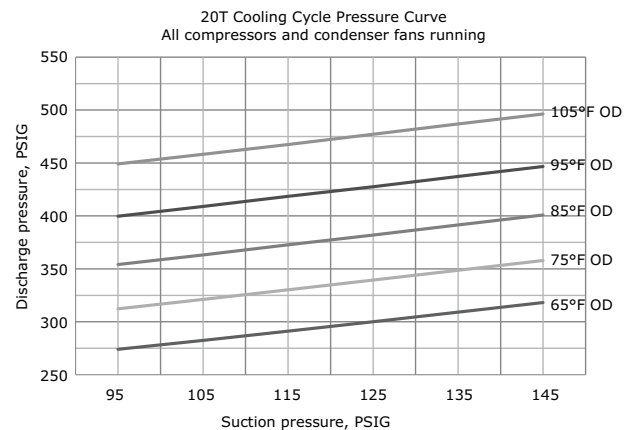

Figure 76. 25 Ton cooling cycle pressure curve

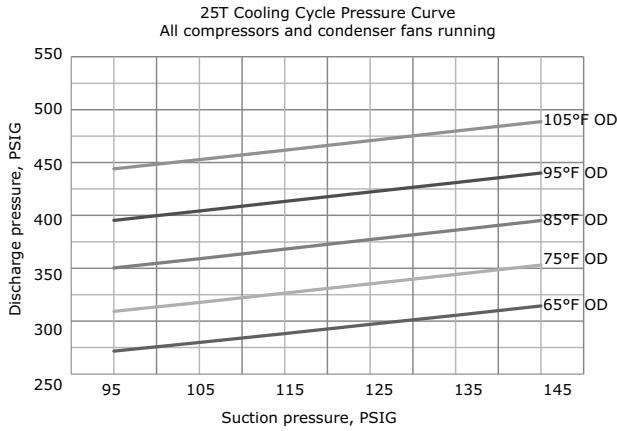

Figure 79. 50 Ton cooling cycle pressure curve

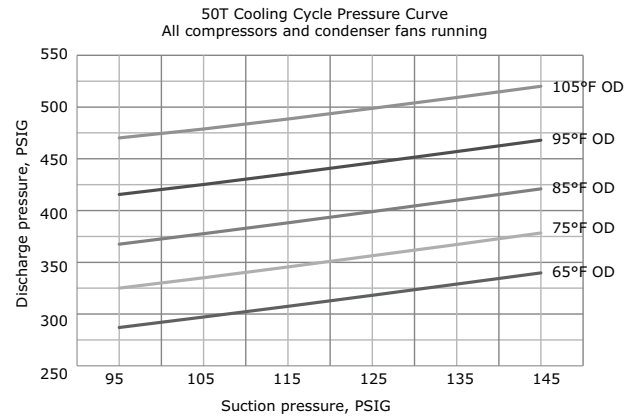

Figure 77. 30 Ton cooling cycle pressure curve

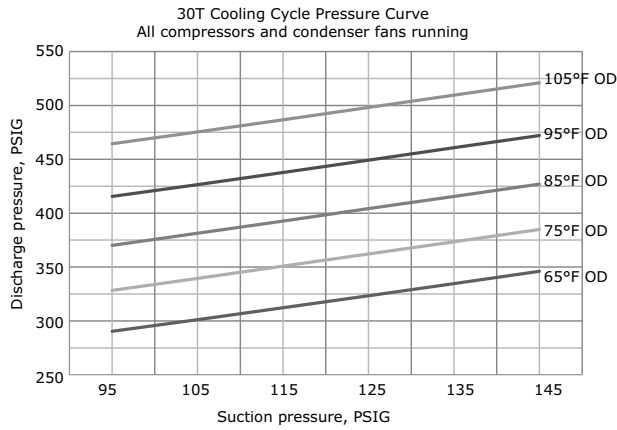

Figure 80. 60 Ton cooling cycle pressure curve

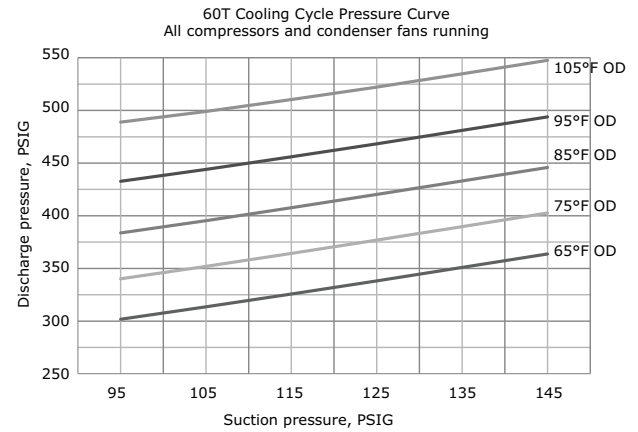

Figure 78. 40 Ton cooling cycle pressure curve

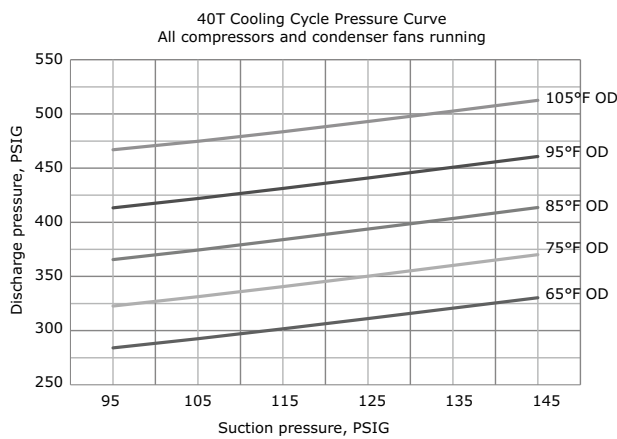

Figure 81. 80 Ton cooling cycle pressure curve

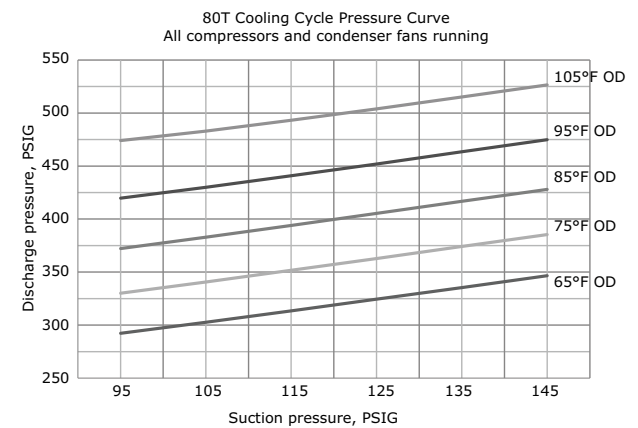

Figure 82. 100 Ton cooling cycle pressure curve

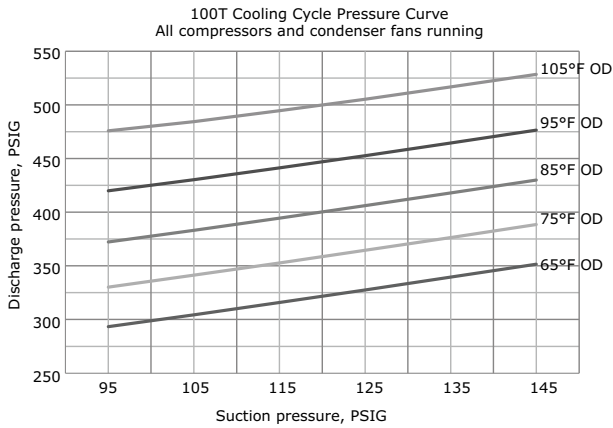
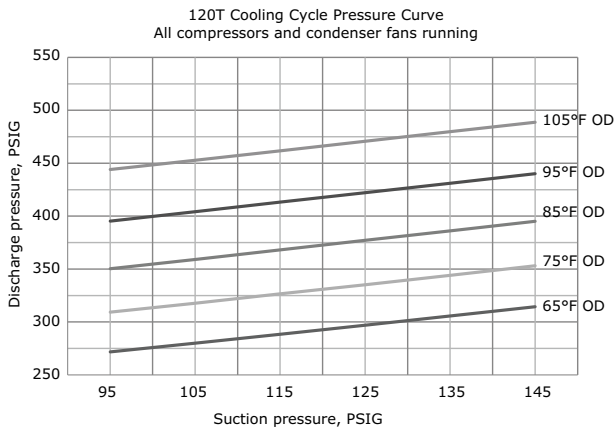

Figure 83. 120 Ton cooling cycle pressure curve



Final System Setup

⚠ WARNING

Hazardous Voltage!
 Failure to disconnect power before servicing could result in death or serious injury. Disconnect all electric power, including remote disconnects before servicing. Follow proper lockout/tagout procedures to ensure the power can not be inadvertently energized. Verify that no power is present with a voltmeter.

After completing the Pre-start and Start-up procedures outlined in the previous sections, perform these final checks before leaving the unit:

- Turn the 115 volt control circuit switch 1S2 "Off" and program the Night Setback (NSB) panel (if applicable) for proper unoccupied operation. Refer to the programming instructions for the specific panel.
- Verify "System" selection switch and the "Fan Mode" selection switch at the Remote panel is set correctly.
- Verify that the "System" control switch for the supply fan is "On".
- Verify that the "System" control switch for the supply fan or the chilled water pump is "On."
- Set the correct "Operating Temperature" for the system at the system controller. Refer to Minimum Starting Ambient Temperature table for the recommended control set points for the appropriate control option.
- Turn the 115 volt control circuit switch 1S2 "On". The system will start automatically once a request for cooling has been given.
- Verify that all exterior panels and the control panel doors are secured in place.

Table 38. Recommended operating setpoints, 20 to 120 ton units

Control	Control Setting	Recommended Setting
Discharge Air Controller (VAV units only)	Supply Air Setpoint	Set at design discharge (supply) air temperature; minimum setting = 55° F
	Reset Setpoint	Set at maximum amount of allowable reset for supply air setpoint.
	Control Band	Set at 6°F Minimum Setpoint
Chiller Control (EVP units only) Freezestat	Leaving Fluid Setpoint	Set at design leaving chilled water temperature (typically) 44° F
	Reset Setpoint	Set at maximum amount of allowable reset for leaving fluid setpoint.
	Control Band	Set at 6° F Minimum Setpoint (minimum control temperature cannot be lower than freezestat setting)
Freezestat	Low Limit Solution Temperature	Set at 5° F Minimum above the Chilled Solution Freeze Temperature
Zone Thermostat (CV units only)	Zone Setpoint	Set at desired space temperature.

Note: For "No Controls" Units, see System Engineer

Table 39. Sample maintenance log

Date	Current Ambient Temp. (°F)	Refrigerant Circuit #1						Refrigerant Circuit #2							
		Compr Oil level	Suct. Press. (psig)	Disch. Press. (psig)	Liquid Press. (psig)	Liq Line Temp (°F)	Super-heat (°F)	Sub-cool (°F)	Compr Oil level	Suct. Press. (psig)	Disch. Press. (psig)	Liquid Press. (psig)	Liq Line Temp (°F)	Super-heat (°F)	Sub-cool (°F)
		-ok- Low													
		-ok- Low													
		-ok- Low													
		-ok- Low													
		-ok- Low													
		-ok- Low													
		-ok- Low													
		-ok- Low													
		-ok- Low													
		ok- Low													

Note: Check and record the data requested above each month during the cooling season with the unit running



Maintenance

Monthly Maintenance

Air Handling Equipment

⚠ WARNING

Hazardous Voltage!

Failure to disconnect power before servicing could result in death or serious injury.

Disconnect all electric power, including remote disconnects before servicing. Follow proper lockout/tagout procedures to ensure the power can not be inadvertently energized. Verify that no power is present with a voltmeter.

Before completing the following checks, turn the system control circuit switch 1S2 and 5S1 to the "Off" position. Open the main power disconnect switch for the Condensing Unit and Air Handling Unit and "lock it" in the "Off" position before removing any access panels.

- Inspect the return air filters. Clean or replace them if necessary.
- Check the evaporator drain pan and condensate piping to ensure that there are no blockages.
- Inspect the evaporator coils for dirt. If the coils appear dirty, clean them according to the instructions described in ["Coil Cleaning," p. 56,](#) [p. 119.](#)
- Inspect the economizer damper hinges and pins (if applicable) to ensure that all moving parts are securely mounted. Clean the blades as necessary.
- Verify that all damper linkages move freely. Lubricate with white grease, if necessary.
- Check Supply Fan motor bearings. Repair or replace the motor as necessary.
- Check the fan shaft bearings for wear. Replace the bearings as necessary.
- Lubricate supply fan bearings. Contact equipment manufacturer for recommended greases.

NOTICE

Bearing Damage!

Over lubrication could result in as much damage to fan bearings as not enough grease.

To prevent damage to fan bearings, do not over lubricate.

Important: Use a hand grease gun to lubricate bearings. Add grease until a light bead appears all around the seal.

After greasing the bearings, check the setscrews to ensure that the shaft is held securely to the bearings and fan wheels. Make sure that all bearing supports are tight.

- Check the supply fan belt(s). If the belts are frayed or worn, replace them.
- Verify that all wire terminal connections are tight.
- Inspect unit for unusual conditions (e.g., loose access panels, leaking piping connections, etc.)
- When checks are complete, verify all retaining screws are reinstalled in unit access panels.

Condensing Unit

⚠ WARNING

Rotating Components!

Failure to disconnect power before servicing could result in rotating components cutting and slashing technician which could result in death or serious injury.

Disconnect all electric power, including remote disconnects before servicing. Follow proper lockout/tagout procedures to ensure the power can not be inadvertently energized.

- Manually rotate the condenser fans to ensure free movement and check motor bearings for wear. Verify that all of the fan mounting hardware is tight.
- Verify that all wire terminal connections are tight.
- Inspect the condenser coils for dirt and foreign debris. If the coils appear dirty, clean them according to the instructions described in Coil Cleaning section.
- Inspect the compressor and condenser fan motor contactors. If the contacts appear severely burned or pitted, replace the contactor. Do not clean the contacts.
- Check the compressor oil level. (Compressors "Off")

Coil Cleaning

NOTICE

Damaging Coil Cleaners!

Coil cleaners can damage roofs, surrounding buildings, vehicles, etc.

Cleaning substances should be checked to ensure that they will not cause damage to surroundings. Coils and roof (if applicable) should be rinsed thoroughly. Do not spray coil cleaners in windy conditions.

Regular coil maintenance, including annual cleaning, enhances unit's operating efficiency by minimizing:

- compressor head pressure and amperage draw;
- water carryover;
- fan brake horsepower; and,
- static pressure losses.

At least once each year—or more often if the unit is located in a “dirty” environment—clean the microchannel condenser using the instructions outlined below. Be sure to follow these instructions as closely as possible to avoid damaging the coils.

To clean refrigerant coils, use a soft brush and a sprayer.

Note: DO NOT use any detergents with microchannel condenser coils. Pressurized water or air ONLY.

1. Remove enough panels from the unit to gain safe access to coils..

⚠ WARNING

No Step Surface!

Failure to follow instruction below could result in death or serious injury.

Do not walk on the sheet metal drain pan. Walking on the drain pan could cause the supporting metal to collapse and result in the operator/technician falling.

Important: Bridging between the main supports required before attempting to enter into the unit. Bridging may consist of multiple 2 by 12 boards or sheet metal grating.

2. Straighten any bent coil fins with a fin comb.
3. For accessible areas, remove loose dirt and debris from both sides of the coil. For dual row microchannel condenser coil applications, seek pressure coil wand extension through the local Trane Parts Center.

Note: DO NOT use any detergents with microchannel coils. Pressurized water or air ONLY.

4. Pour the cleaning solution into the sprayer. If a high-pressure sprayer is used:

- a. The minimum nozzle spray angle is 15 degrees.
 - b. Do not allow sprayer pressure to exceed 600 psi.
 - c. Spray the solution perpendicular (at 90 degrees) to the coil face.
5. Spray the leaving-airflow side of the coil first; then spray the opposite side of the coil. For evaporator and reheat coils, allow the cleaning solution to stand on the coil for five minutes.
 6. Rinse both sides of the coil with cool, clean water.
 7. Inspect both sides of the coil; if it still appears to be dirty, repeat Steps 6 and 7.
 8. Reinstall all of the components and panels removed in Step 1; then restore power to the unit.
 9. For evaporator and reheat coils, use a fin comb to straighten any coil fins which were inadvertently bent during the cleaning process.

Microchannel Condenser Coil Repair and Replacement

If microchannel condenser coil repair or replacement is required, see Service Guide document RT-SVB83*-EN for further details.

EVP Remote Evaporator Chiller

The brazed plate evaporator is difficult to clean should it become plugged with debris so proper installation and maintenance of the inlet water strainer is important. Particles larger than 0.039” entering the heat exchanger could block flow passages causing a failure. Indications of a plugged BPHE evaporator include “wet” suction due to lack of heat exchange, loss of superheat control, depressed discharge superheat (superheat less than 63°F), compressor oil dilution and/or starvation and premature compressor failure.

Minimum water flow rate must be maintained to avoid laminar flow, potential evaporator freezing, scaling and poor temperature control.

NOTICE

Heat Exchanger Damage!

Freezing and heat exchanger damage could occur if water flow is interrupted.

Do not stop water flow with the refrigeration system running.

Maximum water flow rate must not be exceeded to avoid possible erosion.

Water Strainer Maintenance

To protect the evaporator and for maximum efficiency, the strainer must be cleaned. A differential pressure gauge installed across the inlet and outlet will indicate pressure loss due to clogging and may be used as a guide to determine when cleaning is required.



Maintenance

Normally when differential pressure reaches 5-10 psi, the screen must be cleaned. To clean, open and flush out until any sediment is removed.

EVP Evaporator Replacement

If the evaporator requires replacement, it is very important that the new evaporator be replaced correctly and with the correct refrigerant and water piping connections. The refrigerant inlet/liquid connection is at the bottom of the evaporator and the refrigerant outlet/suction connection is at the top of the evaporator and both are on the same side. Pay particular attention to evaporators with dual circuits. Avoid cross-circuiting when installing the new evaporator. Proper brazing techniques for dissimilar materials must be followed, see "Brazing Procedures" section.

Water Loop

If the water loop is drained for an extended period, pipe sections between the strainer and the heat exchanger should be cleaned or replaced, to prevent rust buildup from entering the chiller.

Scroll Compressor

Operational Sounds

The following discussion describes some of the operational sounds of Trane R-410A scroll compressors. These sounds do not affect the operation or reliability of the compressor.

Shutdown

When a Scroll compressor shuts down, the gas within the scroll expands and causes momentary reverse rotation until the discharge check valve closes. This results in a "flutter" type sound.

Low Ambient Start-Up

When the compressor starts up under low ambient conditions, the initial flow rate of the compressor is low due to the low condensing pressure. This causes a low differential across the thermal expansion valve that limits its capacity. Under these conditions, it is not unusual to hear the compressor rattle until the suction pressure climbs and the flow rate increases.

Failure Diagnosis and Replacement

The RAUJ product does not have microelectronics that provide compressor failure diagnostic capability at the unit level. CSHN compressors (used in 80 to 120 ton RAUJ units) do include a module in each compressor junction box that recognizes certain fault conditions. Refer to Unit Description section of this manual for protection features included with RAUJ units. For more detailed information regarding compressor failure diagnosis and replacement of scroll compressors, refer to COM-SVN01*-EN.

The tables in Compressor Circuit Breakers section the specific compressor electrical and the circuit breaker trip information. A tripped circuit breaker does not necessarily mean a compressor has failed, but if the circuit breaker has not tripped the compressor is probably good. Verify first that simpler problems don't exist including: low pressure, high pressure, discharge temperature, or power supply phasing and voltage issues.

Refrigerant Evacuation and Charging

⚠ WARNING

R-410A Refrigerant under Higher Pressure than R-22!

Failure to use proper equipment or components as described below, could result in equipment failing and possibly exploding, which could result in death, serious injury, or equipment damage.

The units described in this manual use R-410A refrigerant which operates at higher pressures than R-22. Use ONLY R-410A rated service equipment or components with these units. For specific handling concerns with R-410A, please contact your local Trane representative.

⚠ WARNING

Refrigerant under High Pressure!

Failure to follow instructions below could result in an explosion which could result in death or serious injury or equipment damage.

System contains refrigerant under high pressure. Recover refrigerant to relieve pressure before opening the system. See unit nameplate for refrigerant type. Do not use non-approved refrigerants, refrigerant substitutes, or refrigerant additives.

The compressor manifold system was designed to provide proper oil return to each compressor. The refrigerant manifold must not be modified in any way. Should a compressor replacement become necessary and a suction line filter drier is to be installed, install it at least the minimum distance upstream of the suction manifold tee as shown in illustrations shown in Suction Line Filter section. See SS-APG012-EN for recommended suction filter selections.

NOTICE

Compressor Damage!

Altering the manifold piping could cause oil return problems and compressor failure.

Do not alter compressor manifold piping.

NOTICE

Compressor Damage!

Failure to follow these instructions could result in compressor failure.

If it becomes necessary to remove or recharge the system with refrigerant, it is important that the following actions are taken.

- To prevent cross contamination of refrigerants and oils, use only dedicated R-410A service equipment.
- Disconnect unit power before evacuation and do not apply voltage to compressor while under vacuum.
- Due to presence of POE oil, minimize system open time. Do not exceed 1 hour.
- When recharging R-410A refrigerant, follow procedures outlined in the Start-Up section of this IOM.
- Allow the crankcase heater to operate a minimum of 24 hours before starting the unit.

Important: Do not spill compressor oil. Refrigerant oil is detrimental to some roofing materials. Care must be taken to protect the roof from oil leaks or spills.

Important: Do not release refrigerant to the atmosphere! If adding or removing refrigerant is required, the service technician must comply with all federal, state, and local laws

Compressor Replacement

Discoloration of the oil indicates that an abnormal condition has occurred. If the oil is dark and smells burnt, it has overheated, which could be a result of the following:

- compressor operating at extremely high condensing temperatures
- high superheat
- compressor mechanical failure

OR

- occurrence of a motor burnout

If a motor burnout is suspected, use an acid test kit (KIT15496) to check the condition of the oil. Test results will indicate an acid level has exceeded the limit if a burnout occurred. Oil test kits must be used for POE oil (OIL00079 for a quart container or OIL00080 for a gallon container) to determine whether the oil is acidic. If a motor burnout has occurred, change the oil in all compressors in a tandem or trio set.

CSHD Compressors (20 to 60 Ton)

For CSHD compressors this will require that the oil be removed using a suction or pump device through the oil equalizer Rotolock fitting, see , p. 121. Use a

dedicated device for removing oil. It is good practice to flush the suction device with clean oil prior to use. Place a catch pan under the oil equalizer Rotolock connection fitting on the compressor to catch the oil that will come out of the compressor when the oil equalizer tube is removed from the compressor.

Prior to reinstalling the oil equalizer line to each compressor, replace the Teflon gasket on the oil equalizer Rotolock fitting on each compressor. See Figure 85, p. 121. Torque Rotolock nut to the values listed in Table 41, p. 122.

Charge the new oil into the Schrader valve on the shell of the compressor. Due to the moisture absorption properties of POE oil, do not use POE oil from a previously opened container. Also discard any excess oil from the container that is not used.

CSHN Compressors (80 to 120T)

CSHN compressors have an oil drain valve, see , p. 121, which allows the oil to be drained out of the compressor. After the refrigerant has been recovered, pressurize the system with nitrogen to help remove the oil from the compressor.

Figure 84. Scroll compressor external features

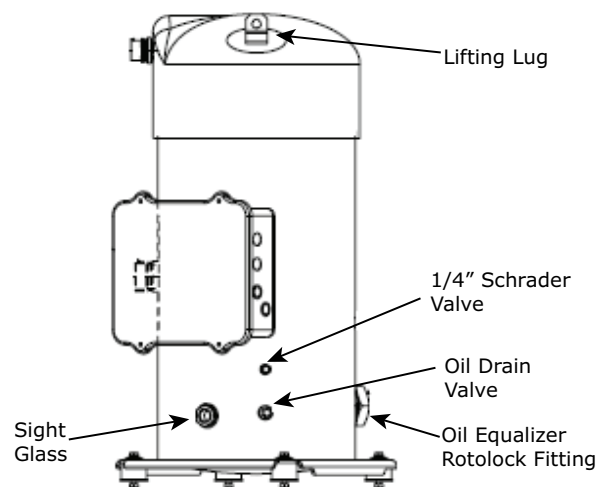
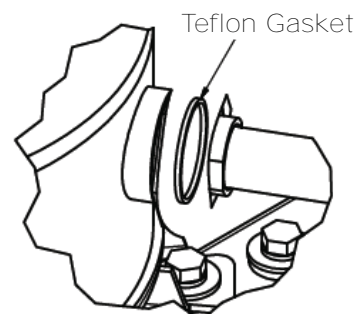

Figure 85. Teflon gasket



Charge the new oil into the Schrader valve or oil drain valve on the shell of the compressor. Due to the moisture absorption properties of POE oil, do not use POE oil from a previously opened container. Also discard any excess oil from the container that is not used.

Table 40. Oil charge per compressor

Compressor	Pints
CSHD 110 thru 183	7.0
CSHN 176 thru 250	14.2

Table 41. Torque requirements for rotolock fittings

Compressor	Torque (ft-lbs)
CSHD*	64 +/- 12
CSHN*	100 +/- 10

Note: Always replace gasket when reassembling oil equalizer lines.

Electrical Phasing

It is very important to review and follow the Electrical Phasing procedure described in the startup procedure of this document.

If the compressors are allowed to run backward for even a very short period of time, internal compressor damage could occur and compressor life could be reduced.

If a scroll compressor is rotating backwards, it will not pump, make a loud rattling sound, low side shell gets hot, and draw ½ expected amps. Immediately shut off the unit. Ensure that unit phasing is correct. If the incorrect phasing is determined to be at one compressor, interchange any two compressor leads to correct the motor phasing.

Compressor Circuit Breakers

Table 43. Compressor circuit breakers (200-230 volts)

Unit	Voltage	Must Hold			Must Trip		
		1A / 2A	1B / 2B	1C / 2C	1A / 2A	1B / 2B	1C / 2C
20 Ton	200	50.4	50.4	-	58	58	-
	230	43.2	43.2	-	49.7	49.7	-
25 Ton	200	50.4	63.1	-	58	72.5	-
	230	43.2	57.1	-	49.7	65.7	-
30 Ton	200	69.3	69.3	-	79.7	79.7	-
	230	59.4	59.4	-	68.3	68.3	-
40 Ton	200	50.4	50.4	-	58	58	-
	230	43.2	43.2	-	49.7	49.7	-

Precision Suction Restrictor

RAUJ tandems with unequal compressors and all RAUJ trios use precision suction restrictors to balance the oil levels in the compressors. For manifolded compressors in RA units, this restrictor is placed in the compressor indicated in [Table 42, p. 122](#). When replacing this compressor, it is imperative that the proper restrictor is selected from those provided with the replacement compressor.

When the compressors are restarted verify that correct oil levels are obtained when all compressors are running in a manifold set.

Figure 86. Precision suction restrictor

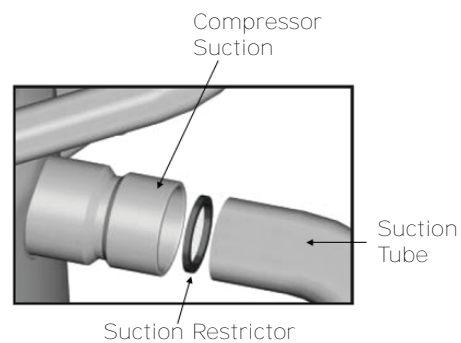

Table 42. Suction restrictor location

Unit Size	Circuit	Compressor
25 Ton	1A	CSHD125
50 Ton	1A, 2A	CSHD142
80 Ton	1C, 2C	CSHN176
100 Ton	1A, 1B, 2A, 2B	CSHN184
120 Ton	1C, 2C	CSHN250

Table 43. Compressor circuit breakers (200-230 volts) (continued)

Unit	Voltage	Must Hold			Must Trip		
		1A / 2A	1B / 2B	1C / 2C	1A / 2A	1B / 2B	1C / 2C
50 Ton	200	57.1	63.1	-	65.7	72.5	-
	230	51.4	57.1	-	59.2	65.7	-
60 Ton	200	69.3	69.3	-	79.7	79.7	-
	230	59.4	59.4	-	68.3	68.3	-
80 Ton	200	73.7	73.7	73.7	84.7	84.7	84.7
	230	63.1	63.1	63.1	72.5	72.5	72.5
100 Ton	200	73.7	73.7	105.2	84.7	84.7	121
	230	63.1	63.1	90.7	72.5	72.5	104.3
120 Ton	200	105	105.2	105.2	121	121	121
	230	90.7	90.7	90.7	104.3	104.3	104.3

Table 44. Compressor circuit breakers (460-575 volts)

Unit	Voltage	Dial Setting		
		1A / 2A	1B / 2B	1C / 2C
20 Ton	460	20.8	20.8	-
	575	17.7	17.7	-
25 Ton	460	20.8	24.9	-
	575	17.7	21.4	-
30 Ton	460	28.5	28.5	-
	575	25.9	25.9	-
40 Ton	460	20.8	20.8	-
	575	17.7	17.7	-
50 Ton	460	22.6	24.9	-
	575	19.1	21.4	-
60 Ton	460	28.5	28.5	-
	575	25.9	25.9	-
80 Ton	460	28.4	28.4	28.4
	575	22.7	22.7	22.7
100 Ton	460	28.4	28.4	41.6
	575	22.7	22.7	33.3
120 Ton	460	41.6	41.6	41.6
	575	33.3	33.3	33.3

Suction Line Filter

Figure 87. Suction line filter installation: 20 to 60 Ton units

Minimum 16" for CSHD straight unobstructed piping between the Suction Filter/Drier and the Tee

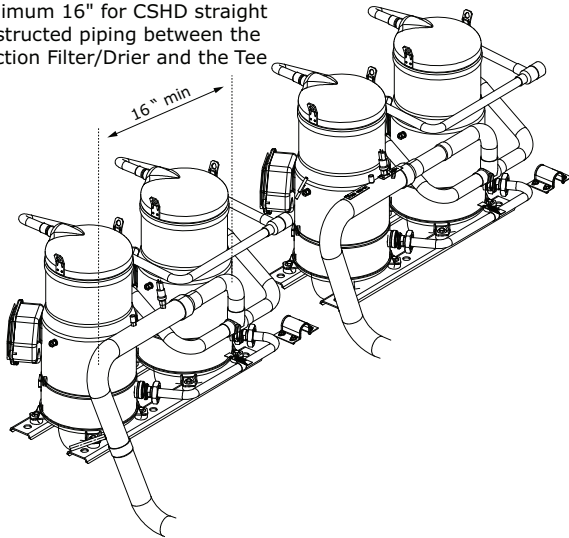
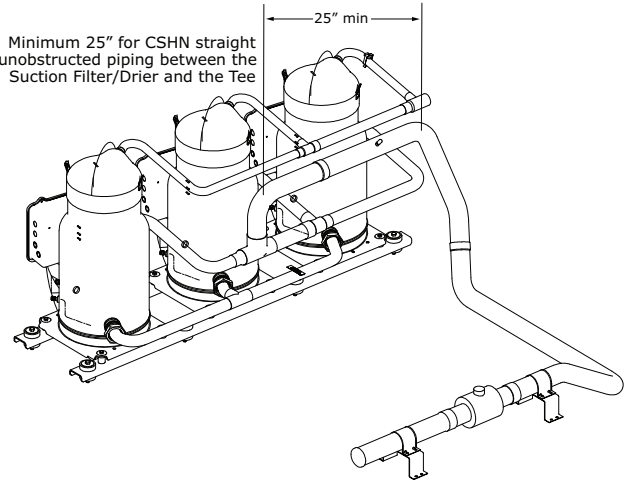

Figure 88. Suction line filter installation: 80 to 120 Ton units

Minimum 25" for CSHN straight unobstructed piping between the Suction Filter/Drier and the Tee



Fuse Replacement Data

Table 45. Fuse replacement selection

Fuse Description	Unit Size	Unit Voltage	Fuse Type	Fuse Size
Condenser Fan Fuse (1F1-1F3 on 20 - 30 Ton) (1F1-1F6 on 40 - 60 Ton)	20-60 Ton	200/230 460/575 380/415	Class RK5	25 Amp 15 Amp
Control CKT Fuse 1F7	20 - 30 40 - 60	All	Class CC FNQ R	3.2 6.25
Compressor Protector Fuse 1F8 on 20 - 60 ton 1F9 on 40 - 60 ton	20 - 60 Ton	All	ABC - 6	6 Amp
Control Circuit Fuse 1F1	80 - 120	All	Class CC FNQ-R	10 Amp
Compressor Protector Fuse 1F2 - 1F3	80 - 120	All	ABC - 6	6 AMP
Condenser Fan Fuse 1F4-1F9	80	200 V 230 V 460 V 575 V	Class RK5	30 Amp 25 Amp 20 Amp 15 Amp
Condenser Fan Fuse 1F4-1F9	100 - 120	200 / 230 V 460 V 575 V	Class RK5	35 Amp 25 Amp 20 Amp
Transformer Fuse 1F12 - 1F13	All	200 V 230 V 460 V	FNQ-R	6 Amp 5 Amp 4 Amp

Fall Restraint – Condenser Roof

⚠ WARNING

Falling Off Equipment!

Failure to follow instructions below could result in death or serious injury.

This unit is built with fall restraint slots located on unit top that **MUST** be used during servicing. These slots are to be used with fall restraint equipment that will not allow an individual to reach the unit edge. However such equipment will **NOT** prevent falling to the ground, as they are **NOT** designed to withstand the force of a falling individual.

This unit is built with fall restraint slots located on unit top that must be used during servicing. See figures below.

Figure 89. Fall restraint slot

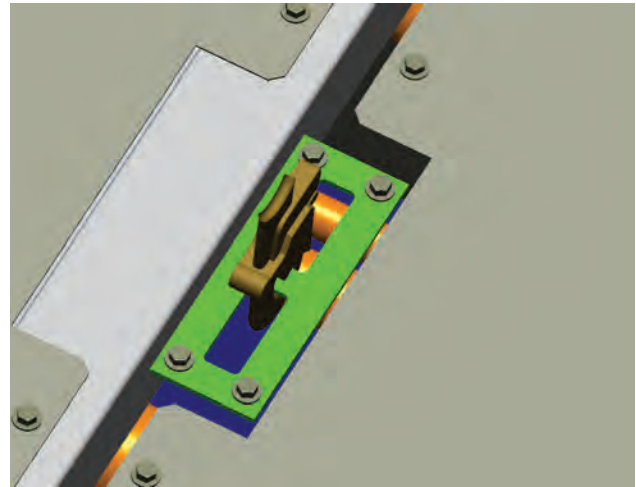
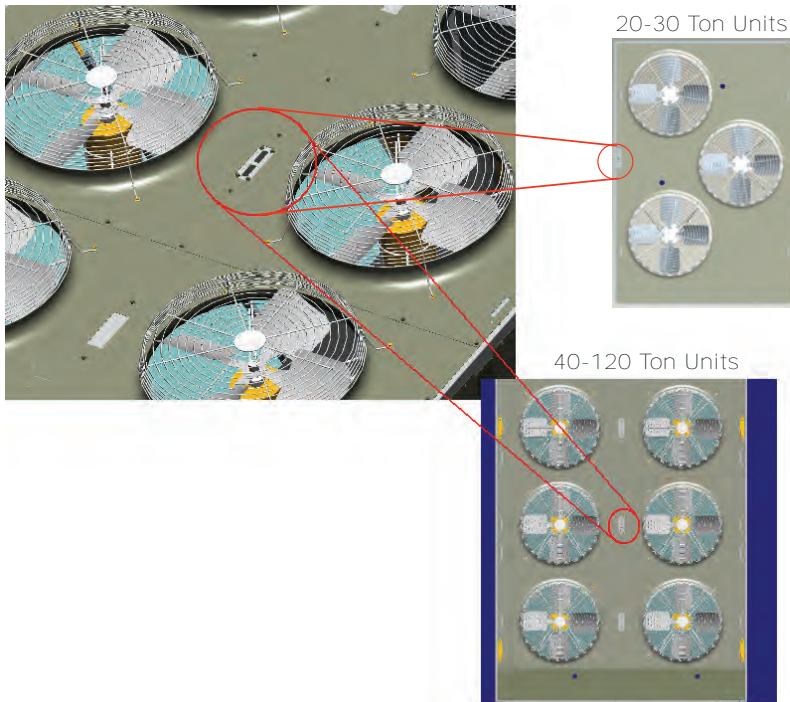

Figure 90. Fall restraint slot location





Warranty and Liability Clause

Commercial Equipment Rated 20 Tons and Larger and Related Accessories

Products Covered

This warranty* is extended by Trane Inc. and applies only to commercial equipment rated 20 Tons and larger and related accessories.

The Company warrants for a period of 12 months from initial start-up or 18 months from date of shipment, whichever is less, that the Company products covered by this order (1) are free from defects in material and workmanship and (2) have the capacities and ratings set forth in the Company's catalogs and bulletins, provided that no warranty is made against corrosion, erosion or deterioration. The Company's obligations and liabilities under this warranty are limited to furnishing f.o.b. factory or warehouse at Company designated shipping point, freight allowed to Buyer's city (or port of export for shipment outside the conterminous United States) replacement equipment (or at the option of the Company parts therefore) for all Company products not conforming to this warranty and which have been returned to the manufacturer. The Company shall not be obligated to pay for the cost of lost refrigerant. No liability whatever shall attach to the Company until said products have been paid for and then said liability shall be limited to the purchase price of the equipment shown to be defective.

The Company makes certain further warranty protection available on an optional extra-cost basis. Any further warranty must be in writing, signed by an officer of the Company.

The warranty and liability set forth herein are in lieu of all other warranties and liabilities, whether in contract or in negligence, express or implied, in law or in fact, including implied warranties of merchantability and fitness for particular use. In no event shall the Company be liable for any incidental or consequential damages.

THE WARRANTY AND LIABILITY SET FORTH HEREIN ARE IN LIEU OF ALL OTHER WARRANTIES AND LIABILITIES, WHETHER IN CONTRACT OR IN NEGLIGENCE, EXPRESS OR IMPLIED, IN LAW OR IN FACT, INCLUDING IMPLIED WARRANTIES OF MERCHANTABILITY AND FITNESS FOR PARTICULAR USE, IN NO EVENT SHALL WARRANTOR BE LIABLE FOR ANY INCIDENTAL OR CONSEQUENTIAL DAMAGES.

Manager - Product Service

Trane Inc.

Clarksville, Tn 37040-1008

PW-215-2688

*Optional Extended Warranties are available for compressors and heat exchangers of Combination Gas-Electric Air Conditioning Units.



Wiring Diagrams

Note: Published unit wiring diagrams (individual, separate diagrams for unitary product lines) are available via e-Library.

Drawing Number	Description
2307-4483	Unit Connection Wiring Split - System Condensing Unit Air Cooled RAUJ 20-60 Ton units
2307-4495	Connection-Adder Plates Split System Condensing Unit RAUJ 80-120 Ton units
2307-9116	Power Schematic - Split System Condensing Unit RAUJ 20-60 Ton units
2307-9208	Schematic w/ No System Controls - Split System Condensing Unit RAUJ 20-60 Ton units
2307-9209	Schematic w/ Constant Volume Controls - Split System Condensing Unit RAUJ 20-60 Ton units
2307-9210	Schematic w/ Variable Air Volume Controls - Split System Condensing Unit RAUJ 20-60 Ton units
2307-9211	Schematic w/ EVP Controls - Split System condensing Unit RAUJ 20-60 Ton units
2307-9212	Connection - Main Control Box & Raceway Devices - Split System Condensing Unit RAUJ 20-60 Ton units
2307-9122	Field Connection Diagram - Split System Condensing Unit RAUJ 20-60 Ton units
2307-9218	Power Schematic - Split System Condensing Unit RAUJ 80-120 Ton units
2307-9214	Schematic - Air Cooled Diagram - Split System Condensing Unit RAUJ 80-120 Ton units w/No Controls
2307-9215	Schematic - Air Cooled Diagram - Split System Condensing Unit RAUJ 80-120 Ton units w/Variable Air Volume Controls
2307-9216	Schematic - Air Cooled Diagram - Split System Condensing Unit RAUJ 80-120 Ton units w/EVP Controls
2307-9217	Connection - Air Cooled Control Box Diagram - Split System Condensing Unit RAUJ 80-120 Ton units
2307-9144	Field Connection Air Cooled Diagram - Split System Condensing Unit RAUJ 80-120 Ton units
2307-9219	Connection Raceway Diagram - Split System Condensing Unit RAUJ 80-120 Ton units
2307-3900	Connection - Low Ambient Damper Option 20-120 Ton units

Trane - by Trane Technologies (NYSE: TT), a global innovator - creates comfortable, energy efficient indoor environments for commercial and residential applications. For more information, please visit trane.com or tranetechnologies.com.

Trane has a policy of continuous product and product data improvements and reserves the right to change design and specifications without notice. We are committed to using environmentally conscious print practices.

SS-SVX11M-EN 09 Jul 2021
Supersedes SS-SVX11L-EN (June 2020)

©2021 Trane