

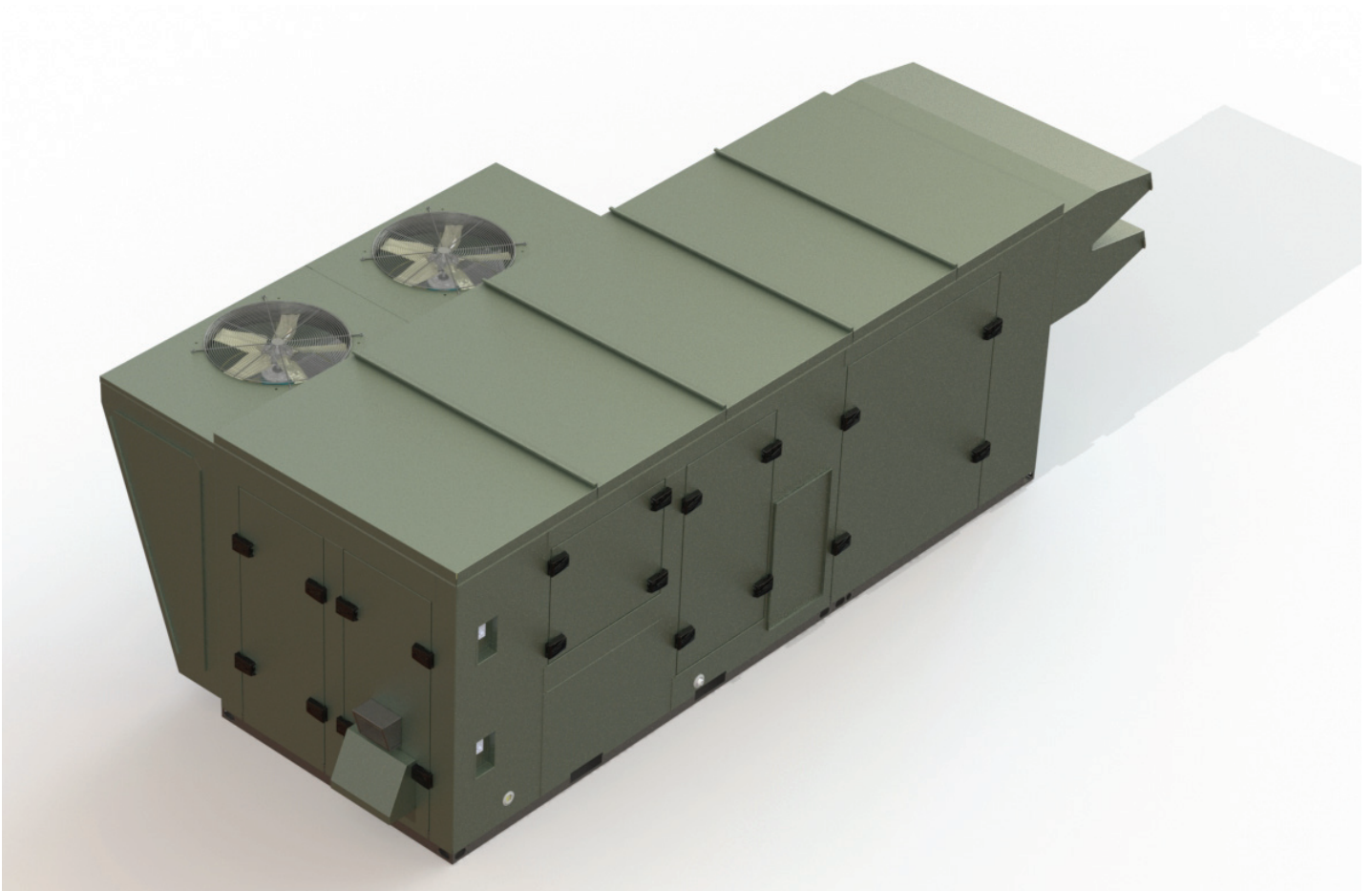

Product Catalog

Horizon™ Outdoor Air Unit For 100% Outdoor Air Applications

Model: OADG and OANG





Introduction

The Horizon Outdoor Air Unit...

The Trane DX Horizon™ Outdoor Air Unit for 100 percent outdoor air or dew point design applications leads the industry in:

- Indoor Air Quality (IAQ) Features
- Moisture Management
- High Quality and Durability
- Advanced Controls

Figure 1. OADG unit components

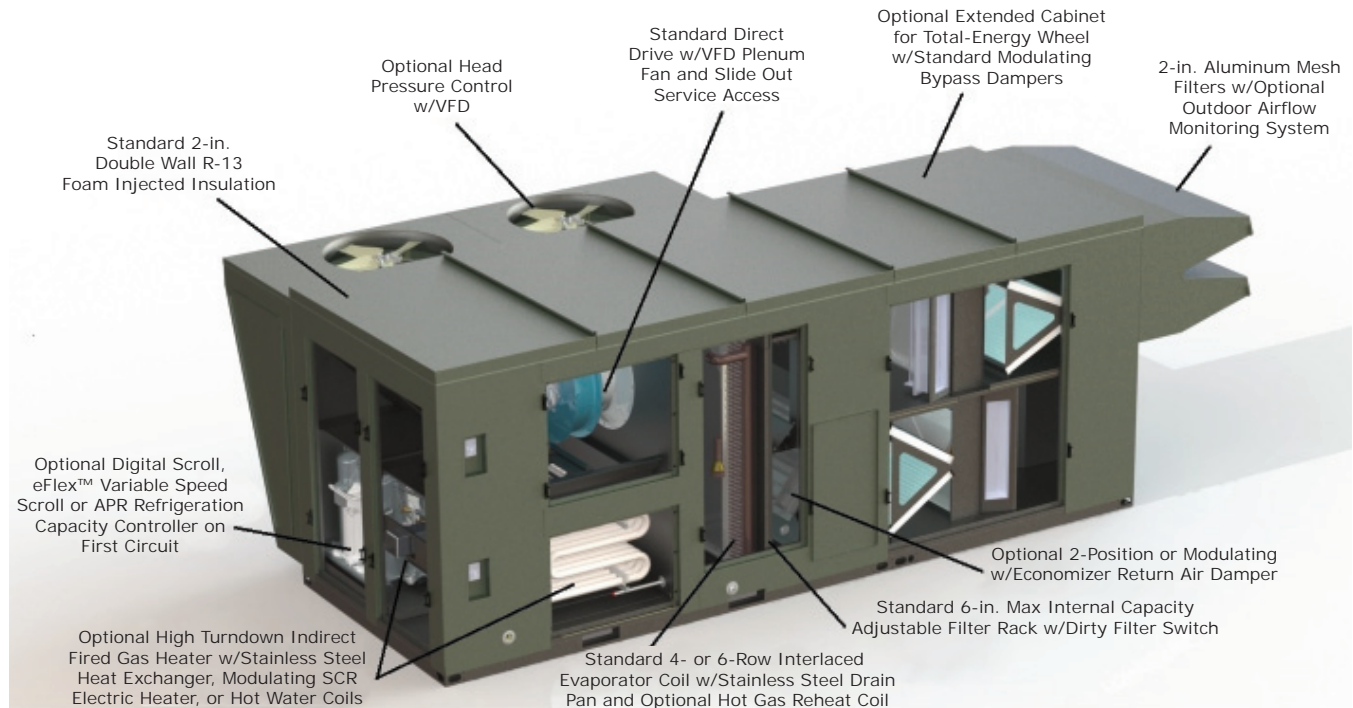

Copyright

This document and the information in it are the property of Trane, and may not be used or reproduced in whole or in part without written permission. Trane reserves the right to revise this publication at any time, and to make changes to its content without obligation to notify any person of such revision or change.

Trademarks

All trademarks referenced in this document are the trademarks of their respective owners.



Table of Contents

Introduction	2
Horizon Outdoor Air Unit	5
Model: OADG and OANG	5
Model Number Descriptions	5
Features and Benefits	8
Indoor Air Quality (IAQ) Features	8
Energy Efficiency	8
High Quality and Durability	8
Advanced Controls	8
Flexibility	9
Enhanced Serviceability	9
Standard Unit Features	9
Standard Control Features	9
Optional Features	9
Application Considerations	11
Overview	11
Outdoor Air Unit Functions	11
System Configurations	11
Horizon OAU Operation	12
OAU with Reheat	12
Dehumidification	12
Cooling or Heating	13
OAU Outdoor Air Control without Reheat	13
Dehumidification	14
Establishing Capacity Requirements	14
Cooling & Dehumidification Selection Criteria	15
Evaporator Design Entering Conditions	15
Evaporator Design Leaving Conditions	15
Reheat	15
Heating	16
Capacity Control	17
Discharge Air Control	17
Cooling Setpoint	17
Unoccupied Space Humidity Control	17
Space Control	18
Outdoor Airflow Balancing	18
Air to Air Energy Recovery	18
Controlling the Total-Energy Wheel	18
Cross Leakage	19
Condensate Drain Configuration	19
Acoustical Considerations	20



Table of Contents

Clearance Requirements	20
Duct Design	21
Controls Sequence	21
General Data	22
Unit Clearances, Curb Dimensions, and Dimensional Data	27
OAD Units	27
Unit Clearances	27
Curb Dimensions	29
Dimensional Data	30
OAN Units	33
Unit Clearances	33
Curb Dimensions	35
Dimensional Data	36
Indirect Gas-fired Furnace Heater and Power	39
Unit Weight and Rigging	41
Unit Weight	41
Rigging and Center-of-Gravity	42
Mechanical Specifications	45
Horizon Outdoor Air Mechanical Specifications	45
Refrigeration and Dehumidification Systems	45
Electrical and Controls	49
Options	50
Appendix	53
OAU Filter Guide	53



Model Number Descriptions

Horizon Outdoor Air Unit

Model: OADG and OANG

Digit 1, 2 – Unit Type

OA = Outdoor Air

Digit 3 – Cabinet Size

D = 1250–8000 cfm
N = 5000–25000 cfm

Digit 4 – Major Design Sequence

G = Revision 6

Digit 5, 6, 7 – Normal Gross Cooling Capacity (MBh)

000 = No DX Cooling
010 = 10 Tons High Efficiency
012 = 12 Tons High Efficiency
015 = 15 Tons High Efficiency
017 = 17 Tons High Efficiency
020 = 20 Tons High Efficiency
040 = 40 Tons High Efficiency
045 = 45 Tons High Efficiency
050 = 50 Tons High Efficiency
055 = 55 Tons High Efficiency
060 = 60 Tons High Efficiency
065 = 65 Tons High Efficiency
070 = 70 Tons High Efficiency
075 = 75 Tons High Efficiency
080 = 80 Tons High Efficiency

Digit 8 – Airflow Configuration

A = Vertical Discharge/No Return
B = Horizontal Discharge/No Return
C = Vertical Discharge/Vertical Return
D = Vertical Discharge/Horizontal Return/Exhaust
E = Horizontal Discharge/Vertical Return/Exhaust
F = Horizontal Discharge/Horizontal Return/Exhaust
G = Vertical Discharge/Vertical Return/Vertical Exhaust
H = Vertical Discharge/Vertical Return/Horizontal Exhaust
J = Vertical Discharge/Horizontal Return/Vertical Exhaust
K = Vertical Discharge/Horizontal Return/Horizontal Exhaust
L = Horizontal Discharge/Vertical Return/Vertical Exhaust
M = Horizontal Discharge/Vertical Return/Horizontal Exhaust
N = Horizontal Discharge/Horizontal Return/Vertical Exhaust
P = Horizontal Discharge/Horizontal Return/Horizontal Exhaust

Digit 9 – Voltage Selection

1 = 208/60/3
2 = 230–240/60/3
3 = 460/60/3
4 = 575/60/3

Digit 10 – Not Used

Digit 11 – Indoor Coil Type

0 = No Indoor Coil
C = DX 4-Row
D = DX 6-Row
F = Glycol/Chilled Water Coil—4-Row
G = Glycol/Chilled Water Coil—6-Row
H = Glycol/Chilled Water Coil with Cooney Freeze Block Technology—4-Row
J = Glycol/Chilled Water Coil with Cooney Freeze Block Technology—6-Row

Digit 12 – Reheat

0 = No Reheat
A = Fin and Tube Modulating HGRH

Digit 13 – Compressor

0 = No Compressor
A = Scroll Compressors
B = Digital Scroll—1st Circuit Only
C = Digital Scroll—1st Circuit and 2nd Circuit

Digit 14 – Outdoor Coil

0 = No Condenser
1 = Air-cooled Fin and Tube
3 = Water-cooled Copper/Nickel
4 = Water-cooled Copper/Steel
5 = ASHP Fin and Tube
7 = WSHP Copper/Nickel
8 = WSHP Copper/Steel

Digit 15 – Refrigerant Capacity Control

0 = No RCC Valve
1 = RCC Valve on 1st Circuit

Digit 16 – Heat Type—Primary

0 = No Heat
A = Indirect Fired NG (IF)—Standard Efficiency (80%)
B = Indirect Fired NG (IF)—High Efficiency (82%)
D = Indirect Fired LP (IF)—Standard Efficiency (80%)
E = Indirect Fired LP (IF)—High Efficiency (82%)
G = Hot Water
H = Electric—Staged
J = Electric—SCR Modulating

Digit 17 – Heat Capacity—Primary

	IE	ELEC	HOT WATER
0	= No Heat		
A	= 50 MBh	5 kW	1 Row/10 FPI
B	= 75 MBh	10 kW	1 Row/12 FPI
C	= 100 MBh	15 kW	1 Row/14 FPI
D	= 125 MBh	20 kW	2 Row/10 FPI
E	= 150 MBh	24 kW	2 Row/12 FPI
F	= 200 MBh	28 kW	2 Row/14 FPI
G	= 250 MBh	32 kW	3 Row/10 FPI
H	= 300 MBh	40 kW	3 Row/12 FPI
J	= 350 MBh	48 kW	3 Row/14 FPI
K	= 400 MBh	60 kW	
L	= 500 MBh	68 kW	
M	= 500 MBh	79 kW	(Dual 250)
N	= 600 MBh	99 kW	
P	= 600 MBh	111 kW	(Dual 300)
R	= 800 MBh	119 kW	
S	= 800 MBh	139 kW	(Dual 400)
T	= 1000 MBh	159 kW	
U	= 1000 MBh	179 kW	(Dual 500)
V	= 1200 MBh	199 kW	
W	=	215 kW	
Y	=	230 kW	
Z	=	250 kW	

Digit 18 – Heat Type—Secondary

0 = No Secondary Heat
4 = Electric—Staged

Digit 19 – Heat Capacity—Secondary

0 = No Secondary Heat
A = 5 kW
B = 10 kW
C = 15 kW
D = 20 kW
E = 24 kW
F = 28 kW
G = 32 kW
H = 40 kW
J = 48 kW
K = 60 kW
L = 68 kW
M = 79 kW
N = 99 kW
P = 111 kW



Model Number Descriptions

R = 119 kW

Digit 20 — Not Used

Digit 21 — Supply Fan Motor

A = 1 hp—1800 rpm
 B = 1 hp—3600 rpm
 C = 1.5 hp—1800 rpm
 D = 1.5 hp—3600 rpm
 E = 2 hp—1800 rpm
 F = 2 hp—3600 rpm
 G = 3 hp—1800 rpm
 H = 3 hp—3600 rpm
 J = 5 hp—1800 rpm
 K = 5 hp—3600 rpm
 L = 7.5 hp—1800 rpm
 M = 7.5 hp—3600 rpm
 N = 10 hp—1800 rpm
 P = 10 hp—3600 rpm
 R = 15 hp—1800 rpm
 S = 15 hp—3600 rpm
 T = 20 hp—1800 rpm
 U = 20 hp—3600 rpm

Digit 22 — Supply Fan Motor Type

1 = Direct Drive w/VFD
 2 = Direct Drive (VFD by Others)
 3 = Direct Drive w/Shaft Grounding Ring w/VFD

Digit 23, 24 — Supply Fan Wheel Diameter

AA = 12-in. Wheel
 AB = 12-in.—60% Width Wheel
 AC = 14-in. Wheel
 AD = 14-in.—60% Width Wheel
 AE = 16-in. Wheel
 AF = 16-in.—60% Width Wheel
 AG = 18-in. Wheel
 AH = 18-in.—60% Width Wheel
 AJ = 20-in. Wheel
 AK = 20-in.—60% Width Wheel
 AL = 22-in. Wheel
 AM = 22-in.—60% Width Wheel
 AN = 25-in. Wheel
 AP = 25-in.—60% Width Wheel
 BG = Dual 18-in. Wheel
 BH = Dual 18-in.—60% Width Wheel
 BJ = Dual 20-in. Wheel
 BK = Dual 20-in.—60% Width Wheel
 BL = Dual 22-in. Wheel
 BM = Dual 22-in.—60% Width Wheel
 BN = Dual 25-in. Wheel
 BP = Dual 25-in.—60% Width Wheel

Digit 25 — Exhaust Fan Motor

0 = No Powered Exhaust
 A = 1 hp—1800 rpm
 B = 1 hp—3600 rpm
 C = 1.5 hp—1800 rpm
 D = 1.5 hp—3600 rpm
 E = 2 hp—1800 rpm
 F = 2 hp—3600 rpm
 G = 3 hp—1800 rpm
 H = 3 hp—3600 rpm
 J = 5 hp—1800 rpm
 K = 5 hp—3600 rpm
 L = 7.5 hp—1800 rpm
 M = 7.5 hp—3600 rpm
 N = 10 hp—1800 rpm
 P = 10 hp—3600 rpm
 R = 15 hp—1800 rpm

S = 15 hp—3600 rpm
 T = 20 hp—1800 rpm
 U = 20 hp—3600 rpm

Digit 26 — Exhaust Fan Motor Type

0 = No Powered Exhaust
 1 = Direct Drive w/VFD
 2 = Direct Drive (VFD by Others)
 3 = Direct Drive w/Shaft Grounding Ring w/VFD

Digit 27, 28 — Exhaust Fan Wheel Diameter

00 = No Powered Exhaust
 AA = 12-in. Wheel
 AB = 12-in.—60% Width Wheel
 AC = 14-in. Wheel
 AD = 14-in.—60% Width Wheel
 AE = 16-in. Wheel
 AF = 16-in.—60% Width Wheel
 AG = 18-in. Wheel
 AH = 18-in.—60% Width Wheel
 AJ = 20-in. Wheel
 AK = 20-in.—60% Width Wheel
 AL = 22-in. Wheel
 AM = 22-in.—60% Width Wheel
 AN = 25-in. Wheel
 AP = 25-in.—60% Width Wheel
 BG = Dual 18-in. Wheel
 BH = Dual 18-in.—60% Width Wheel
 BJ = Dual 20-in. Wheel
 BK = Dual 20-in.—60% Width Wheel
 BL = Dual 22-in. Wheel
 BM = Dual 22-in.—60% Width Wheel
 BN = Dual 25-in. Wheel
 BP = Dual 25-in.—60% Width Wheel

Digit 29 — Powered Exhaust Fan Motor (PFM) and Exhaust Dampers

0 = No Piezo Ring
 1 = Supply Fan Piezo Ring
 2 = Exhaust Fan Piezo Ring
 3 = Supply Fan Piezo Ring and Exhaust Fan Piezo Ring

Digit 30 — Not Used

Digit 31 — Unit Controls

0 = No Controls
 1 = Space Control
 2 = Discharge Air Control
 3 = Multi-Zone VAV
 4 = Single-Zone VAV

Digit 32 — Building Interface

0 = No Controls
 1 = BACnet®
 3 = LON

Digit 33 — Filter Options

0 = No Filters
 A = MERV-8, 30%
 B = MERV-13, 80%
 C = MERV-14, 95%
 D = MERV-8 30%, MERV-13 80%
 E = MERV-8 30%, MERV-14 95%

Digit 34 — Energy Recovery

0 = No Energy Recovery
 1 = ERV—Composite Construction with Bypass for Frost Protection
 2 = ERV—Composite Construction with Frost Protection w/VFD
 3 = ERV—Aluminum Construction with Bypass for Frost Protection
 4 = ERV—Aluminum Construction with Frost Protection w/VFD

Digit 35 — Energy Recover Option, Purge

0 = No Purge
 1 = Purge

Digit 36 — Energy Recover Wheel Size

0 = No ERV
 A = 3014
 B = 3622
 C = 4136
 D = 4634
 E = 5262
 F = 5856
 G = 6488
 H = 6876
 J = 74122
 K = 81146
 L = 86170
 M = 92180

Digit 37 — Energy Recovery Option, Rotation Sensor

0 = No Rotation Sensor
 1 = Rotation Sensor

Digit 38 — Damper Options

1 = 100% OA 2-Position Damper
 2 = 100% OA 2-Position Damper w/RA 2-Position Damper
 3 = Modulating OA and RA Dampers w/Economizer
 4 = Modulating OA Damper

Digit 39 — Exhaust Dampers

0 = No Exhaust Dampers
 A = Gravity Dampers
 B = Isolation Dampers
 C = Barometric Relief Dampers

Digit 40 — Not Used

Digit 41 — Electrical Options

0 = Terminal Block—No Factory Installed Disconnect
 A = Non-Fused Disconnect
 B = Fused Disconnect Switch
 C = 65 SCCR Electrical Rating w/Non-Fused Disconnect
 D = 65 SCCR Electrical Rating w/Fused Disconnect
 E = 65 KAIC Electrical Rating w/Non-Fused Disconnect
 F = 65 KAIC Electrical Rating w/Fused Disconnect
 G = Dual Point Power
 H = Dual Point Power 65 KAIC
 J = Dual Point Power 65 SCCR

Model Number Descriptions

Digit 42 – Corrosive Environment Package

- 0 = No Corrosive Package
- A = Eco Coated Coils
- B = S/S Interior
- C = S/S Coil Casing
- D = S/S Coil Casing with Eco Coated Coils
- E = S/S Interior, Eco Coated Coils
- F = Corrosion Resistant Package

Digit 43 – Outdoor Air Monitoring

- 0 = No Outdoor Air Monitoring
- 1 = Airflow Probes

Digit 44 – Condenser Fan Options

- 0 = No Condenser Fans
- A = Standard Condenser Fan
- B = Passive Head Pressure Control
- C = Active Head Pressure Control
- D = ECM Condenser Fans with Active Head Pressure Control
- E = ECM Condenser Fans with Active Head Pressure Control for Sound Attenuation

Digit 45 – Compressor Sound Blankets and Sound Attenuation

- 0 = No Sound Attenuation Package
- A = Compressor Sound Blankets
- B = Compressor Sound Blankets with Sound Attenuation Condenser Fans

Digit 46 – Smoke Detector

- 0 = No Smoke Detector
- 1 = Supply Smoke Detector
- 2 = Return Smoke Detector
- 3 = Supply and Return Smoke Detector

Digit 47 – Hailguards

- 0 = No Hailguards
- A = Hailguards

Digit 48 – Service Lights

- 0 = No Service Lights
- A = Supply Fan Section Service Light
- B = Exhaust Fan Section Service Light
- C = Supply and Exhaust Fan Section Service Light

Digit 49 – UV Lights

- 0 = No UV Lights
- 1 = UV Lights

Digit 50 – Not Used

Digit 51 – Unit Installation Location

- A = Outdoor
- B = Indoor

Digit 52 – Convenience Outlet

- 0 = No Convenience Outlet
- A = Convenience Outlet

Digit 53 – Controls Display

- 0 = No Display
- 1 = TD7 Factory Installed
- 2 = TD7 Remote Mounted

OAU-PRC004C-EN

Digit 54 – Cooling Controls

- 0 = No ReliaTel™
- A = ReliaTel™
- B = ReliaTel™ with BCIR Card

Digit 55 – Face and Bypass on Indoor Coil

- 0 = No Face and Bypass

Digit 56 – Thermostat

- 0 = No Thermostat
- 1 = Thumbwheel Thermostat

Digit 57 – Altitude

- 0 = Sea Level to 1000 Feet
- 1 = 1001 to 2000 Feet
- 2 = 2001 to 3000 Feet
- 3 = 3001 to 4000 Feet
- 4 = 4001 to 5000 Feet
- 5 = 5001 to 6000 Feet
- 6 = 6001 to 7000 Feet
- 7 = Above 7000 Feet

Digit 58 – Condensate Overflow Switch

- 0 = No Condensate Overflow Switch
- A = Condensate Overflow Switch

Digit 59 – Froststat

- 0 = No Froststat™
- A = Froststat™ Installed

Digit 60 – Not Used

Digit 61 – Outdoor Coil Fluid Type

- 0 = None
- 1 = Water
- 2 = Ethylene Glycol
- 3 = Propylene Glycol
- 4 = Methanol
- 5 = Other

Digit 62 – Minimum Damper Leakage

- 0 = Standard
- 1 = Class 1A

Digit 63, 64, 65, 66, 67, 68, 69 – Reserved for Future Use



Features and Benefits

We designed the Horizon™ Outdoor Air Unit based on customer requirements from across the country. Thorough analysis of the performance requirements resulted in a robust design with the ability to effectively operate over an expansive performance envelope required for the year-round treatment of outdoor air.

Also, we took into account today's HVAC market issues, such as indoor air quality (IAQ). We equipped the Horizon Outdoor Air Unit to meet your ventilation needs—in direct response to the ventilation and humidity control requirements of ASHRAE standard 62.1.

Trane's Horizon Outdoor Air Unit leads the industry in the key areas of:

- indoor air quality (IAQ)
- energy efficiency
- high quality and durability
- advanced, integrated controls
- flexibility (including indoor installation)
- enhanced serviceability

Indoor Air Quality (IAQ) Features

- Stainless steel drain pan sloped in two directions to ensure proper drainage and reduce the potential for microbial growth
- Double-wall foamed panel construction throughout the indoor section of unit to provide, non-porous, cleanable interior surfaces
- Inlet hood with moisture eliminators
- High efficiency throwaway filter option with standard 2-, 4-, or 6-in. adjustable filter rack
- Piezometer airflow measurement option
- Easy filter access encourages frequent changing
- Refrigerant hot gas reheat for low dewpoint supply air for superior humidity control
- Capable of providing low dew point supply air for superior humidity control

Energy Efficiency

- Total energy wheel option for recovered energy from centralized building exhaust
- Optional modulating recovered refrigerant reheat for unit supply air

High Quality and Durability

- Robust unit construction with 2-in. double wall panels with foam insulation for an R-value of 13
- Reversible, hinged access doors
- High quality, long-lasting latches and hinges for all access doors
- Protective standard prepainted finish on cabinet exterior with optional corrosion inhibiting coatings available for the unit exterior, interior and coils

Advanced Controls

- All controls are factory-engineered, mounted, configured and tested to minimize field startup time
- UC600 BACnet® microprocessor control
- Human interface with touch-pad screen for monitoring, setting, editing and controlling
- Capable of supply-air control or zone control of both temperature and relative humidity
- Occupied and unoccupied control sequences
- Optional remote human interface for ease of control access without going outdoors
- Optional LonTalk® communications interface communication link with a Tracer® Summit™ building management system or other control systems that support LonTalk

Flexibility

- Numerous heater options and temperature rise capabilities available
- Multiple roof curb options (1- or 2-in. vibration isolation, horizontal discharge, multiple heights) and seismic certification
- Dual fuel (indirect fired gas primary heat/electric preheat) option

Enhanced Serviceability

- Hinged access doors for ease of maintenance and service
- Easy-open door latches
- Slide out access direct-drive plenum fan
- Optional slide out, self-cleaning total-energy wheel
- Sight glass for each refrigeration circuit
- Optional control display
- High voltage cover

Standard Unit Features

- Multiple cabinet sizes with airflow range from 1,250 to 25,000 cfm
- Two-in. double-wall, R-13 construction (including unit floor and roof) with heavy gauge galvanized metal skin
- Outdoor air inlet hood
- Prepainted exterior finish
- Air-cooled DX refrigeration system
- Completely factory-piped and leak-tested refrigeration system
- Stainless steel drain pans sloped in two planes
- Scroll compressors
- Single-point power connections for units with optional total-energy wheel, powered exhaust, and electric heat
- Filter rack adjustable for 2-, 4-, or 6-in. filters
- Factory-assembled inlet hood with 2-in. mist eliminators
- Non-fused disconnect switch
- Type 439 stainless steel heat exchanger
- Class 2 low leak parallel blade outdoor air damper with edge seals
- High-efficiency fan motors
- Variable frequency drive (VFD)
- Neoprene vibration isolation under supply and exhaust fan base and compressors
- Low ambient operation down to 40°F

Standard Control Features

- Fully integrated, factory-installed and commissioned microelectronic controls
- Supply airflow proving
- Emergency stop for safety interlock
- Mechanical refrigeration capacity control (RCC)
- Occupied/unoccupied control modes
- High turn-down (up to 20:1) modulating indirect gas-fired heat
- Clogged filter switch

Optional Features

- SCR electric heat
- Hot water coils
- Indirect-fired gas heat



Features and Benefits

- Class 1A, ultra low leak parallel blade return air damper with edge seals
- Modulating damper control systems
- Low ambient/head pressure control down to 0°F
- Pleated media filters (2-in. MERV-8, 2-in. MERV-13, 4-in. MERV-14, or a combination 2-in./4-in. filter)
- 120 V UVC downstream of evaporator coil
- Adjustable powered exhaust
- Exhaust dampers (gravity, barometric relief, and 2-position isolation)
- Fused disconnect switch
- Factory-installed smoke detectors (supply and/or return)
- Stainless steel inner liner
- Integral total-energy wheel
- Protective coatings for the coils
- Factory or field-wired convenience outlet
- Air source heat pump
- Hailguards
- LED service lights
- Direct drive BI airfoil plenum fan
- Digital scroll compressors on 1st and 2nd circuits
- Unit mounted human interface panel
- Horizontal supply/return through the unit casing for units with indirect fired gas heat, hot water heat, or no heat option
- Sound attenuation package to reduce radiated sound
- Chilled water coils with optional Cooney Freeze Block
- Compressor sound blankets
- Sound attenuating condenser fans
- Condensate overflow switch
- 65 kA SCCR rating



Application Considerations

Overview

Outdoor Air Unit Functions

The Horizon™ Outdoor Air Unit (OAU) provides conditioned outdoor air suitable for mechanical ventilation or make-up air. The OAU conditions outdoor air as necessary to meet system performance requirements by ventilation with filtration, cooling, dehumidification, and/or heating. The OAU may deliver ventilation air in a number of ways. Refer to “System Configurations,” p. 11 and Figure 4, p. 13, Figure 5, p. 13, and Figure 7, p. 14 for more information.

- Ventilation with Filtration
- Cooling
- Dehumidification
- Heating

System Configurations

Dedicated outdoor air systems can deliver conditioned outdoor air in one of the following ways:

1. Conditioned outdoor air supplied directly to each occupied space, with the local terminal unit controlling the space dry-bulb temperature. Refer to Figure 1, p. 11.
2. Conditioned outdoor air supplied directly to local terminal units, or return ducts of local RTUs, which deliver a mixture of the conditioned outdoor air and (conditioned) recirculated air to the space. Refer to Figure 2, p. 12.
3. Conditioned outdoor air supplied directly to a single space to control the space temperature and humidity. For example, this application will provide temperature and humidity control of ventilated spaces, such as commercial kitchens or laboratories.

Figure 1. Direct discharge to conditioned space

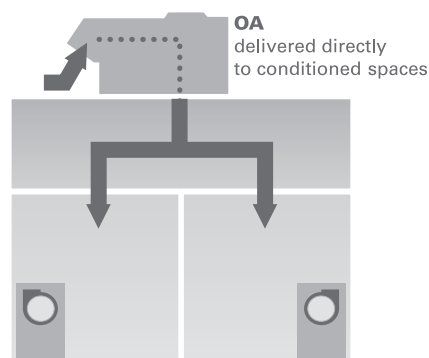
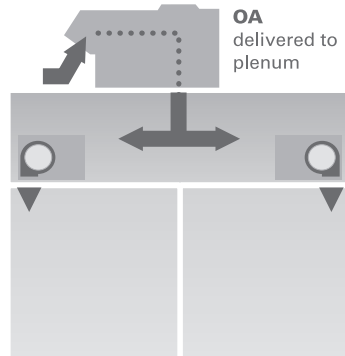

Figure 2. Indirect discharge to fan-coil units



Horizon OAU Operation

The Horizon™ OAU can use either DX cooling, condenser reheat, electric or gas heat to condition outdoor air. The unit controls modulate cooling and heating capacity, reducing the supply air temperature swings associated with staged heating and cooling.

OAU with Reheat

The following figure shows the OAU system with a DX refrigerant circuit design using reheat.

Figure 3. Refrigeration system diagram with reheat

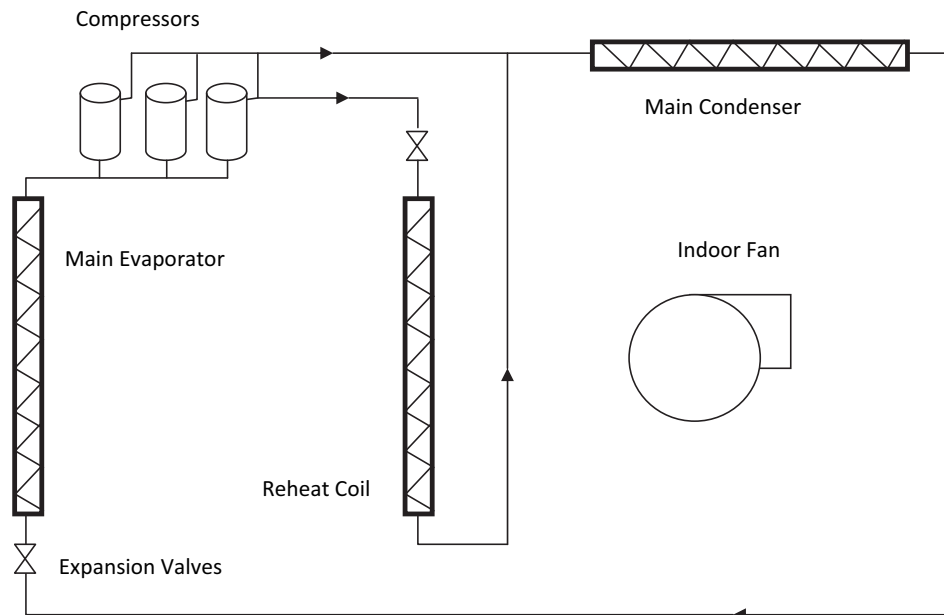

Dehumidification

Consider [Figure 4, p. 13](#). If the outdoor air dew point is above the dehumidification setpoint (or in the case of zone control, the zone RH is above the RH setpoint), the OAU will:

- cool the outdoor air to remove required moisture and
- reheat to meet the discharge temperature setpoint.

At h_1 , 100 percent outdoor air enters the OAU. The OAU filters, cools, and dehumidifies the air as it moves through the evaporator coil. Air leaves the evaporator coil saturated at the preset dew point condition (h_3) and is reheated by the reheat coil to the pre-set reheat temperature setpoint (h_4). The reheat coil transfers energy to the airstream. A liquid solenoid valve effectively modulates the reheat capacity. The outdoor condenser rejects surplus heat. The reheat circuit is first on and last off, so reheat energy is available at full and part load conditions. Since both the dew point setpoint and discharge temperature setpoint are fully adjustable, the desired supply air conditions are maintained at all load conditions.

Figure 4. Psychrometric chart with dehumidification and reheat

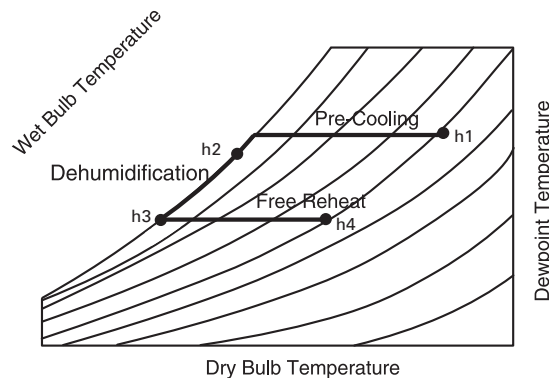

Cooling or Heating

Consider the following figure. If the outdoor air dew point or zone RH is equal to or below the dehumidification setpoint, the OAU will heat or cool the outdoor air to separate cooling or heating setpoints. At t_1 or t_3 , 100 percent outdoor air enters the OAU. The OAU filters, and cools or heats the air as it is drawn through the evaporator and heating section. The air leaves the OAU at the cooling or heating discharge setpoint (t_2 or t_4).

Figure 5. Psychrometric chart with cooling or heating only

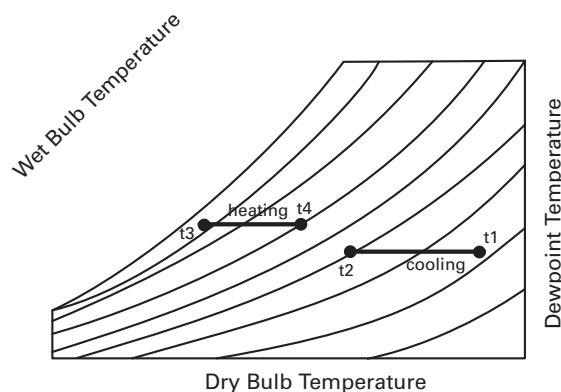

OAU Outdoor Air Control without Reheat

The following figure shows the Horizon™ OAU DX system, using a refrigerant circuit design without reheat.

Note: Space control not available without reheat.

Figure 6. Refrigeration system diagram without reheat

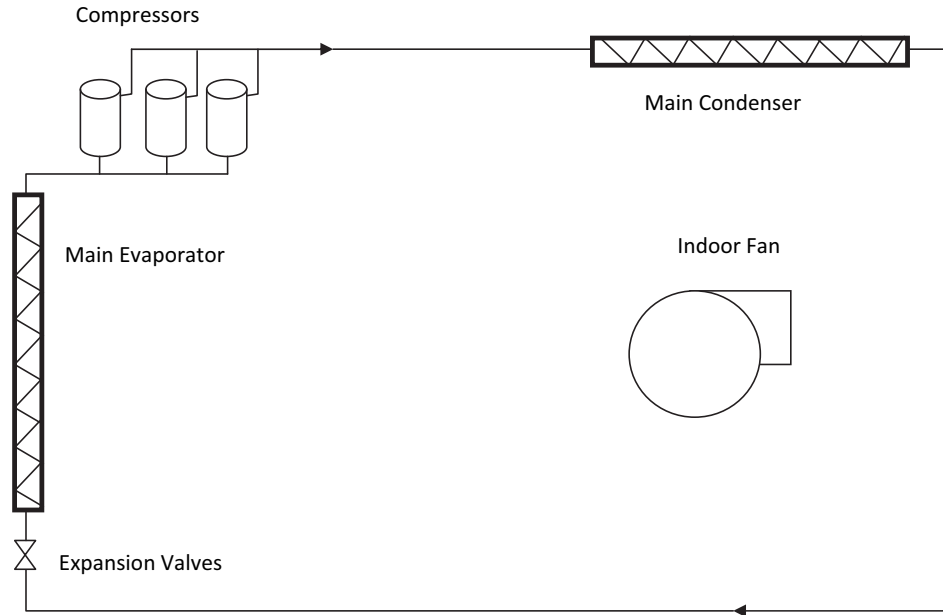

Dehumidification

Consider the following figure. If the outdoor air dew point is above the dehumidification setpoint, the OAU will dehumidify the outdoor air. 100 percent outdoor air enters the OAU (h1). The unit filters, cools and dehumidifies the air as it is drawn through the evaporator coils. Air leaves the evaporator coils saturated at a preset dew point setpoint (h3). Since the dew point setpoint is fully adjustable, the desired dew point condition is maintained at all load conditions.

Figure 7. Psychrometric chart with dehumidification, no reheat

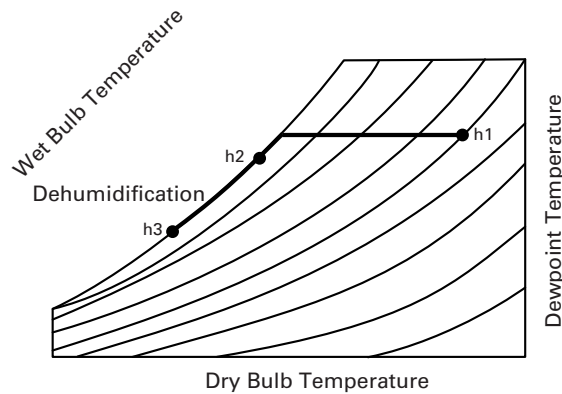

Establishing Capacity Requirements

Determining the OAU capacity requirements requires careful thought. Light Commercial equipment is typically selected based on design **sensible** conditions. Since **latent** loads drive the need for the OAU, base the selection on design **latent** conditions.

Cooling & Dehumidification Selection Criteria

Evaporator Design Entering Conditions

For many climates the peak outdoor air enthalpy occurs at a time when the outdoor dry-bulb temperature is not the highest. Refer to the chapter on climatic design information in the ASHRAE Handbook of Fundamentals. The cooling and dehumidification design condition data is provided three ways:

1. Design dry-bulb temperature with mean coincident wet bulb temperature
2. Design wet-bulb temperature with mean coincident dry-bulb temperature
3. Design dew point temperature with mean coincident dry-bulb temperature

The design wet-bulb condition typically represents a significantly higher outdoor air enthalpy than the design dry-bulb condition. Use the condition that represents the highest enthalpy as the entering evaporator selection condition.

Evaporator Design Leaving Conditions

Due to the uncertainty of the local terminal unit's latent capacity at part load, it is usually most straightforward to size the OAU to handle the entire latent load on the system, both indoor and outdoor. With this design approach, the terminal units may do some latent cooling (dehumidification) during periods of higher sensible load. At these times, the space will run slightly drier than the design RH limit. This is why it makes sense to select the OAU to limit the space RH to a maximum allowable level for those conditions when the terminal units are providing no space latent cooling, such as 60 percent RH. Using lower humidity limits may result in an unnecessary increase in system operating energy use.

Use the tables in "Reheat," p. 15 to identify the appropriate supply air dew point for specific design conditions. For a more detailed discussion on determining the selection criteria of a OAU, refer to SYS-APG001*-EN (*Application Guide: Designing Dedicated Outdoor-Air Systems*) or SYS-APM004*-EN (*Applications Engineering Manual: Dehumidification in HVAC Systems*).

Reheat

Table 1. Supply air dew point temperature, 75°F at 60 percent RH space limit

Latent Load Btu/h per Person	cfm per person										
	10	15	20	25	30	35	40	45	50	55	60
100	54.6	56.6	57.5	58.1	58.4	58.7	58.9	59.0	59.2	59.2	59.3
120	53.3	55.8	57.0	57.6	58.1	58.4	58.6	58.8	58.9	59.1	59.2
140	52.0	55.0	56.4	57.2	57.7	58.1	58.3	58.6	58.7	58.9	59.0
160	50.6	54.2	55.8	56.7	57.3	57.8	58.1	58.3	58.5	58.7	58.8
180	49.2	53.3	55.2	56.3	57.0	57.4	57.8	58.1	58.3	58.5	58.6
200	47.7	52.5	54.6	55.8	56.6	57.1	57.5	57.8	58.1	58.3	58.4
220	46.1	51.6	54.0	55.3	56.2	56.8	57.2	57.6	57.9	58.1	58.3
240	—	50.6	53.3	54.8	55.8	56.5	57.0	57.3	57.6	57.9	58.1
260	—	49.7	52.7	54.3	55.4	56.1	56.7	57.1	57.4	57.7	57.9
280	—	48.7	52.0	53.8	55.0	55.8	56.4	56.8	57.2	57.5	57.7
300	—	47.7	51.3	53.3	54.6	55.5	56.1	56.6	57.0	57.3	57.5
320	—	46.6	50.6	52.8	54.2	55.1	55.8	56.3	56.7	57.1	57.3
340	—	45.5	49.9	52.3	53.8	54.8	55.5	56.1	56.5	56.8	57.1
360	—	—	49.2	51.7	53.3	54.4	55.2	55.8	56.3	56.6	57.0
380	—	—	48.5	51.2	52.9	54.1	54.9	55.5	56.0	56.4	56.8
400	—	—	47.7	50.6	52.5	53.7	54.6	55.3	55.8	56.2	56.6
420	—	—	46.9	50.1	52.0	53.3	54.3	55.0	55.6	56.0	56.4
440	—	—	46.1	49.5	51.6	53.0	54.0	54.7	55.3	55.8	56.2
460	—	—	45.3	48.9	51.1	52.6	53.6	54.4	55.1	55.6	56.0
480	—	—	—	48.3	50.6	52.2	53.3	54.2	54.8	55.4	55.8
500	—	—	—	47.7	50.2	51.8	53.0	53.9	54.6	55.1	55.6

Note: Minimum dew point selectable is 45°F.



Application Considerations

Table 2. Supply air dew point temperature, 75°F at 55 percent RH space limit

Latent Load Btu/h per Person	cfm per person										
	10	15	20	25	30	35	40	45	50	55	60
100	51.6	53.8	54.9	55.5	55.9	56.1	56.3	56.5	56.6	56.7	56.8
120	50.2	53.0	54.2	55.0	55.5	55.8	56.1	56.2	56.4	56.5	56.6
140	48.8	52.1	53.6	54.5	55.1	55.5	55.8	56.0	56.2	56.3	56.4
160	47.2	51.2	53.0	54.0	54.6	55.1	55.5	55.7	55.9	56.1	56.2
180	45.6	50.2	52.3	53.5	54.2	54.8	55.2	55.5	55.7	55.9	56.1
200	—	49.3	51.6	53.0	53.8	54.4	54.9	55.2	55.5	55.7	55.9
220	—	48.3	50.9	52.4	53.4	54.1	54.5	54.9	55.2	55.5	55.7
240	—	47.2	50.2	51.9	53.0	53.7	54.2	54.6	55.0	55.2	55.5
260	—	46.2	49.5	51.4	52.5	53.3	53.9	54.4	54.7	55.0	55.3
280	—	45.1	48.8	50.8	52.1	53.0	53.6	54.1	54.5	54.8	55.1
300	—	—	48.0	50.2	51.6	52.6	53.3	53.8	54.2	54.6	54.9
320	—	—	47.2	49.7	51.2	52.2	53.0	53.5	54.0	54.3	54.6
340	—	—	46.4	49.1	50.7	51.8	52.6	53.3	53.7	54.1	54.4
360	—	—	45.6	48.5	50.2	51.4	52.3	53.0	53.5	53.9	54.2
380	—	—	—	47.9	49.8	51.0	52.0	52.7	53.2	53.7	54.0
400	—	—	—	47.2	49.3	50.6	51.6	52.4	53.0	53.4	53.8
420	—	—	—	46.6	48.8	50.2	51.3	52.1	52.7	53.2	53.6
440	—	—	—	46.0	48.3	49.8	50.9	51.8	52.4	53.0	53.4
460	—	—	—	45.3	47.8	49.4	50.6	51.5	52.2	52.7	53.2
480	—	—	—	—	47.2	49.0	50.2	51.2	51.9	52.5	53.0
500	—	—	—	—	46.7	48.6	49.9	50.9	51.6	52.2	52.7

Note: Minimum dew point selectable is 45°F.

Table 3. Supply air dew point temperature, 75°F at 50 percent RH space limit

Latent Load Btu/h per Person	cfm per person										
	10	15	20	25	30	35	40	45	50	55	60
100	48.4	50.8	51.9	52.6	53	53.3	53.6	53.8	53.9	54	54.1
120	46.8	49.8	51.3	52.1	52.6	53	53.3	53.5	53.6	53.8	53.9
140	45.2	48.9	50.6	51.5	52.2	52.6	52.9	53.2	53.4	53.5	53.7
160	—	47.9	49.8	51	51.7	52.2	52.6	52.9	53.1	53.3	53.5
180	—	46.8	49.1	50.4	51.3	51.8	52.3	52.6	52.9	53.1	53.3
200	—	45.7	48.4	49.8	50.8	51.5	51.9	52.3	52.6	52.8	53.0
220	—	—	47.6	49.3	50.3	51.1	51.6	52	52.3	52.6	52.8
240	—	—	46.8	48.7	49.8	50.7	51.3	51.7	52.1	52.4	52.6
260	—	—	46	48.1	49.4	50.3	50.9	51.4	51.8	52.1	52.4
280	—	—	45.2	47.4	48.9	49.8	50.6	51.1	51.5	51.9	52.2
300	—	—	—	46.8	48.4	49.4	50.2	50.8	51.3	51.6	51.9
320	—	—	—	46.2	47.9	49	49.8	50.5	51	51.4	51.7
340	—	—	—	45.5	47.3	48.6	49.5	50.2	50.7	51.1	51.5
360	—	—	—	—	46.8	48.2	49.1	49.8	50.4	50.9	51.3
380	—	—	—	—	46.3	47.7	48.7	49.5	50.1	50.6	51
400	—	—	—	—	45.7	47.3	48.4	49.2	49.8	50.4	50.8
420	—	—	—	—	45.2	46.8	48	48.9	49.6	50.1	50.6
440	—	—	—	—	—	46.3	47.6	48.5	49.3	49.8	50.3
460	—	—	—	—	—	45.9	47.2	48.2	49	49.6	50.1
480	—	—	—	—	—	45.4	46.8	47.9	48.7	49.3	49.8
500	—	—	—	—	—	—	46.4	47.5	48.4	49.1	49.6

Note: Minimum dew point selectable is 45°F.

The Trane OAU utilizes recovered energy from the cooling process to reheat the air leaving the evaporator coil as required to meet the discharge air setpoint. The reheat refrigeration circuit is adequate to deliver enough reheat to supply neutral-temperature air (e.g., 75°F dry-bulb) under most operating conditions. On very low load days, the reheat circuit may not contain enough energy to meet the desired reheat setpoint.

Heating

The OAU has electric, heat pump, hot water, or gas heat options. The electric heat option is available in 0°F–80°F temperature rise offerings with staged or SCR modulation. This means that the lowest temperature rise provided depends only on heater size and unit airflow. Calculate the

temperature rise to confirm that it provides acceptable control. The electric heat will modulate to maintain heating setpoint.

When using hot water heat, the unit controller will modulate a field-provided coil control valve. Provide an ethylene glycol and water mixture or other means of freeze protection for the hot water coil if the OAU will be subject to sub-freezing temperatures.

Capacity Control

The capacity control system on the Horizon™ Outdoor Air Unit is flexible enough to accommodate a variety of system applications. These applications include:

- treating outdoor air to supply a single space or multiple spaces or
- simultaneously meet building make-up air needs while controlling the temperature and relative humidity of a single space.

Each of these applications requires careful consideration to achieve the desired results.

Discharge Air Control

For many multiple space, dedicated outdoor air systems, the OAU will continuously supply outdoor air at a dry-bulb setpoint and a dew point that does not exceed its dew point setpoint. This control approach is simple because it allows the OAU to function independent of local terminal unit operation or actual space conditions. If the unit selection criteria is determined using the method suggested in [“Establishing Capacity Requirements,” p. 14](#), the Outdoor Air Unit will limit the space relative humidity to the target level.

Many dedicated outdoor air systems supply reheated air directly to terminal units or to spaces that have terminal units performing local sensible cooling. This results in the local terminal units re-cooling the previously re-heated outdoor air. Resetting the supply air dry-bulb temperature of the Outdoor Air Unit offers the opportunity to minimize the amount of time re-cooling occurs. Refer to [“Cooling Setpoint,” p. 17](#) for more information.

Cooling Setpoint

Because the Trane OAU dehumidifies the outdoor air by cooling it, this cool outdoor air can reduce the sensible cooling load on the local terminal unit. At low space sensible loads, the cool outdoor air may sub-cool the space, causing the local terminal unit to add heat (new energy heat). Therefore, reset occupied Space Cooling Setpoint (SPCS—Space Control Sequence) or Evaporator Cooling Setpoint (ECS—Outdoor Air Control Sequence) of the OAU to minimize space sensible re-cooling so the terminal unit with the lowest sensible load is almost at zero cooling capacity (within the limit of the dew point setpoint). To take full advantage of space demand based dry-bulb reset, you may need to size some of the local terminal units based on neutral outdoor air temperature. This strategy will more effectively manage occupant comfort during seasonal changeover for two-pipe terminal unit systems. Because the OAU is not connected to the chiller or boiler plant, accomplish this by resetting the Outdoor Air Unit SPCS or ECS to keep the critical zone at zero heating capacity when the boiler is off and zero cooling capacity when the chiller is off. A Trane Integrated Comfort™ system can provide this control capability.

Unoccupied Space Humidity Control

The Horizon™ OAU provides conditioned outdoor air for the ventilation and/or make-up air needs of a building during occupied hours. It can also limit building relative humidity during unoccupied hours. To do this, provide a return air path to the OAU and place a relative humidity sensor in the space served by the OAU or in a common relief air path (like a return corridor) if the OAU serves multiple spaces. The unit will cycle as required to limit the space humidity to the unoccupied Dewpoint Setpoint (NSDS) setpoint. Reheat and return air damper options are required for this operation. For dedicated outdoor air systems ducted to terminal units, these units must cycle with the operation of the Horizon OAU. A Trane Integrated Comfort™ system can provide this control capability.

Application Considerations

Space Control

For single space applications, the Horizon OAU can control space temperature and limit space relative humidity. To do this, size the airflow to meet whichever is the highest: the space loads and ventilation and/or make-up air needs of the application. Install a temperature sensor in the space to provide temperature control and reset the supply air temperature. If reset of the supply air dew point is desired, install a space relative humidity sensor in the space to provide relative humidity limit control.

Outdoor Airflow Balancing

Establish final unit airflow through a field air balancing procedure. Change the fan speed through VFD Setpoint via the UC600 controller (direct drive fan motor).

Air to Air Energy Recovery

Energy recovery can significantly reduce HVAC system first-cost and operating energy costs. You can use recovered energy for two purposes:

1. to temper or reheat supply air for independent control of sensible and latent capacity, or
2. to precondition outdoor air as it enters the building for ventilation.

The Horizon™ OAU offers refrigerant heat recovery for reheating the supply air. To precondition the outdoor air, use the optional total-energy wheel to recover energy from building exhaust.

Controlling the Total-Energy Wheel

One way to control an energy recovery device is to turn it on and off with the OAU system exhaust fan. In this case, the total energy wheel enables when the unit is in occupied mode and the exhaust fan is running. While this control method is certainly simple and effective in some applications, it may not provide the expected energy saving benefit, particularly when cold air (vs. neutral air) is supplied to the building.

Another more effective approach is to use the outdoor air dry-bulb to determine when to energize or de-energize the energy recovery device. See [Figure 9, p. 19](#) for an example of this simplified control. In addition to being more effective from a control standpoint, it's also a very simple control method because the wheel is enabled when all of the following are true:

- unit is in occupied mode,
- exhaust fan is enabled,
- Unit Main Control Module (MCM) calls for unit to operate in dehumidification, cooling, or heating modes, and
- outside air temperature is above the frost protection setpoint (default setpoint 12°F).

If using the OAU to deliver cold, dry conditioned air to the building (outdoor air is cooled to a low dew point but not reheated), use the cooling setpoint control strategy (see [“Cooling Setpoint,” p. 17](#)).

Figure 8. Dry-bulb control in a cold DB/dry DP application

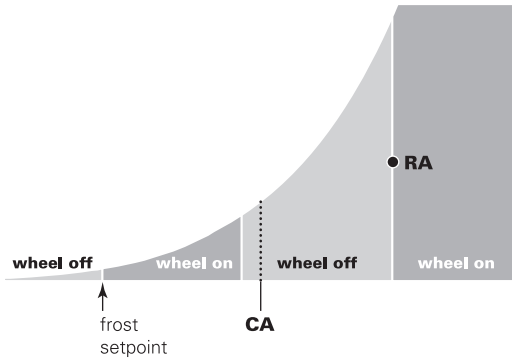
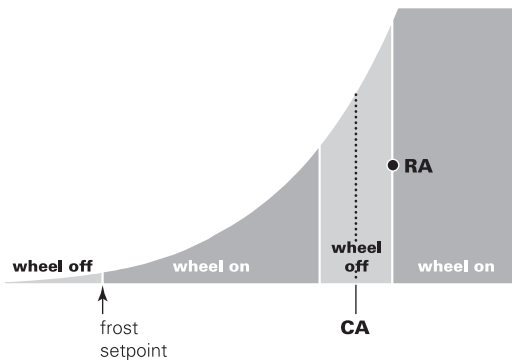

Figure 9. Dry-bulb control in a neutral DB/dry DP application



Cross Leakage

All energy wheels have some cross leakage. Therefore, do not use energy wheels in applications involving toxic or hazardous air streams. The percentage of cross leakage depends on the pressure differentials across the wheel section. With Trane Horizon™ OAU energy wheels, the exhaust air transfer ratios are typically low (less than 4 percent).

Condensate Drain Configuration

OAU units are selected based on dehumidification capability. As such, condensate can form at a high rate. Therefore, the OAU drain pan and condensate line are sized and designed accordingly. However, an often-overlooked element of proper condensate drainage is proper P-Trap and drain line sizing and installation. An incorrectly-designed and -installed P-Trap can restrict condensate flow or cause water in the condensate drain pan to “spit” or “geyser” which may cause condensate overflow. Carefully install and trap the drain pan to ensure adequate condensate removal under all conditions.

An evaporator condensate drain connection is provided on each unit. For more information, refer to OAU-SVX006*-EN (*Installation, Operation, and Maintenance: Horizon Outdoor Air Unit - Model: OADG*).

A condensate trap must be installed at the unit due to the drain connection being on the “negative pressure” side of the fan. Install the P-Trap using the guidelines in the following figure.

Pitch drain lines connected to P-Trap at least 1/2 in. for every 10 feet of horizontal run to assure proper condensate flow. Do not allow the horizontal run to sag causing a possible double-trap condition which could result in condensate backup due to “air lock”.

Application Considerations

Figure 10. Condensate trap installation

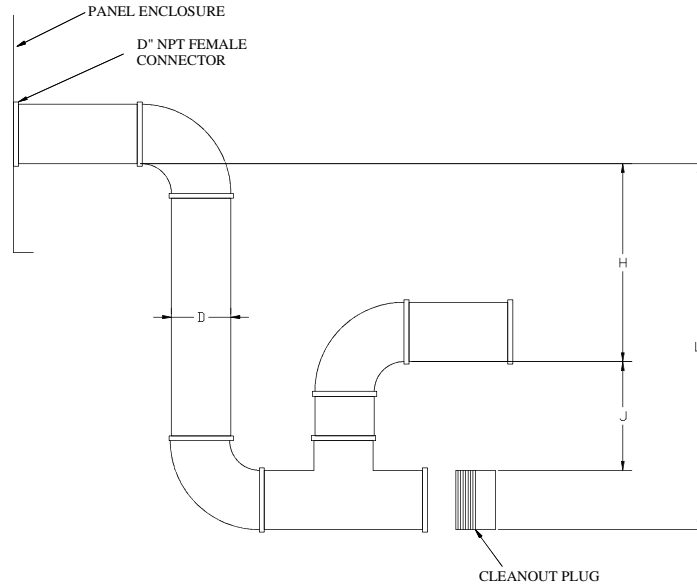

D = PIPE DIAMETER
H = INTERNAL STATIC PRESSURE (IN W.G.) + 1"
J = H * 0.5
L = H + J + D

NOTES: 1. PITCH DRAIN AT LEAST 1/2" PER 10' HORIZONTAL RUN
2. CONDENSATE DRAIN PAN WILL NOT DRAIN PROPERLY IF P-TRAP IS NOT PRIMED & OF ADEQUATE HEIGHT TO ALLOW FOR CABINET OPERATING NEGATIVE PRESSURE

Acoustical Considerations

Proper unit placement is critical to reducing transmitted sound levels from the OAU to the building. Therefore, consider acoustic concerns during the design phase and place the unit accordingly. The most economical means of avoiding an acoustical problem is to place the unit(s) away from acoustically critical areas. If possible, do not locate units directly above areas such as: offices, conference rooms, executive office areas, and classrooms. Instead, ideal locations to consider are: over corridors, utility rooms, toilets, or other areas where higher sound levels directly below the unit(s) are acceptable.

Follow these basic guidelines for unit placement to minimize sound transmission through the building structure.

1. Never cantilever the compressor side of the unit. A structural cross member or full perimeter roof curb, supported by roof structural members, must support this side of the unit.
2. Locate the unit's center of gravity close to or over column or main support beam.
3. If the roof structure is very light, replace roof joists by a structural shape in the critical areas described above.
4. If several units are to be placed on one span, stagger them to reduce deflection over that span.

It is impossible to totally quantify the building structure effect on sound transmission because it is dependent on how the roof and building members respond to the OAU's sound and vibration. However, following the guidelines listed above will help reduce sound transmissions.

Clearance Requirements

Follow the recommended unit clearances to assure adequate serviceability, maximum capacity, and peak operating efficiency. Reducing unit clearances may result in condenser coil starvation or

warm condenser air recirculation. If the recommended clearances are not possible on a particular job, consider the following:

- Do the clearances available allow for major service work, such as changing compressors or coils?
- Do the clearances available allow for proper outside air intake, exhaust air removal, and condenser airflow?
- If screening around the unit is used, is there a possibility of air recirculation from the exhaust to the outside air intake or from condenser exhaust to condenser intake.

Review any actual clearances that appear inadequate with your local Trane sales engineer.

When two or more units are placed side by side, increase the distance between the units to twice the recommended single unit clearance. Stagger the units for these two reasons:

1. To reduce span deflection if more than one unit is placed on a single span. Reducing deflection discourages sound transmission.
2. To assure proper exhaust air diffusion before contact with the adjacent unit's outside air intake.

Duct Design

It is important to note that the rated capacities of the OAU can be met only if the unit is properly installed. A well-designed duct system is essential to meet these capacities.

Satisfactory air distribution throughout the system requires an unrestricted and uniform airflow from the OAU discharge duct.

However, when job conditions dictate installation of elbows near the OAU outlet, using guide vanes may reduce capacity loss and static pressure loss.

Controls Sequence

For sequence of operation, please refer to OAU-SVX006*-EN (*Installation, Operation, and Maintenance: Horizon Outdoor Air Unit - Model: OADG*).



General Data

Table 1. General Data—Cooling 10–20 Tons High Efficiency

	10 Tons Downflow	12 Tons Downflow	15 Tons Downflow	17 Tons Downflow	20 Tons Downflow
	OADG010	OADG012	OADG015	OADG017	OADG020
Cooling Performance (6-row)					
Gross Cooling Capacity, Btu (kW)	134,530 (39.43)	153,380 (44.95)	192,718 (56.48)	215,551 (63.17)	248,068 (72.70)
Nominal cfm (m ³ /h)	1,500 (2,549)	1,800 (3,058)	2,250 (3,823)	2,550 (4,332)	3,000 (5,097)
Cooling Performance (4-row)					
Gross Cooling Capacity, Btu (kW)	135,303 (39.65)	151,147 (44.30)	186,972 (54.80)	213,659 (62.62)	242,918 (71.19)
Nominal cfm (m ³ /h)	4,000 (6,796)	4,800 (8,155)	6,000 (10,194)	6,800 (11,553)	8,000 (13,592)
Compressor					
Number	2	2	2	2	2
Type	Scroll	Scroll	Scroll	Scroll	Scroll
Outdoor Coil					
Type	High-Performance	High-Performance	High-Performance	High-Performance	High-Performance
Tube Size—OD, in. (mm)	3/8 (9.5)	3/8 (9.5)	3/8 (9.5)	3/8 (9.5)	3/8 (9.5)
Face Area, ft ² (m ²)	30 (2.79)	30 (2.79)	30 (2.79)	30 (2.79)	30 (2.79)
Rows	2	2	2	2	2
FPI	14	14	14	14	14
Indoor Coil					
Type	High-Performance	High-Performance	High-Performance	High-Performance	High-Performance
Tube Size (6-row)—OD, in. (mm)	3/8 (9.5)	3/8 (9.5)	3/8 (9.5)	1/2 (12.7)	1/2 (12.7)
Tube Size (4-row)—OD, in. (mm)	3/8 (9.5)	3/8 (9.5)	3/8 (9.5)	3/8 (9.5)	3/8 (9.5)
Face Area, ft ² (m ²)	10 (0.93)	10 (0.93)	10 (0.93)	17 (1.58)	17 (1.58)
Rows	6 or 4	6 or 4	6 or 4	6 or 4	6 or 4
FPI	14 or 15	14 or 15	14 or 15	14 or 15	14 or 15
Refrigerant Control	TXV	TXV	TXV	TXV	TXV
Drain Connection Number	1	1	1	1	1
Drain Connection Size, in. (mm)	1 (25.4)	1 (25.4)	1 (25.4)	1 (25.4)	1 (25.4)
Outdoor Fan					
Type	Propeller	Propeller	Propeller	Propeller	Propeller
Number Used	2	2	2	3	3
Diameter, in. (mm)	27 (685.8)	27 (685.8)	27 (685.8)	27 (685.8)	27 (685.8)
Drive Type	Direct	Direct	Direct	Direct	Direct
No. Speeds	1	1	1	1	1
Fan cfm (m ³ /h)	7,000 (11,893)	7,000 (11,893)	7,000 (11,893)	7,000 (11,893)	7,000 (11,893)
Number Motors	2	2	2	2	2
Motor HP (kW), per motor	1.0 (0.75)	1.0 (0.75)	1.0 (0.75)	1.0 (0.75)	1.0 (0.75)
Motor RPM	1,140	1,140	1,140	1,140	1,140
Indoor Fan					
Type	Airfoil	Airfoil	Airfoil	Airfoil	Airfoil
Number Used	1	1	1	1	1
Diameter, in. (mm)	Varies	Varies	Varies	Varies	Varies
Drive Type	Direct Drive	Direct Drive	Direct Drive	Direct Drive	Direct Drive
Number Motors	1	1	1	1	1
Motor HP (kW)	1–7.5 (0.75–5.59)	1–7.5 (0.75–5.59)	1–7.5 (0.75–5.59)	1–7.5 (0.75–5.59)	1–7.5 (0.75–5.59)
Motor RPM	1750–3500	1750–3500	1750–3500	1750–3500	1750–3500
Motor Frame Size	Varies	Varies	Varies	Varies	Varies
Filters					
Type Furnished	Refer to "OAU Filter Guide" in "Appendix," p. 53	Refer to "OAU Filter Guide" in "Appendix," p. 53	Refer to "OAU Filter Guide" in "Appendix," p. 53	Refer to "OAU Filter Guide" in "Appendix," p. 53	Refer to "OAU Filter Guide" in "Appendix," p. 53
Number Size Recommended					

Table 2. General Data—ASHP 10–20 Tons High Efficiency

	10 Tons Downflow	12 Tons Downflow	15 Tons Downflow	17 Tons Downflow	20 Tons Downflow
	OADG010	OADG012	OADG015	OADG017	OADG020
Performance					
Gross Cooling Capacity, Btu (kW)	131,284 (38.48)	149,705 (43.87)	187,181 (54.86)	217,530 (63.75)	250,834 (73.51)
Gross Heating Capacity, Btu (kW)	85,752 (25.13)	98,970 (29.01)	119,043 (34.89)	145,594 (42.67)	153,122 (44.88)
Nominal cfm (m ³ /h)	1,500 (2,549)	1,800 (3,058)	2,250 (3,823)	2,550 (4,332)	3,000 (5,097)
Compressor					
Number	2	2	2	2	2
Type	Scroll	Scroll	Scroll	Scroll	Scroll
Outdoor Coil					
Type	High-Performance	High-Performance	High-Performance	High-Performance	High-Performance
Tube Size—OD, in. (mm)	3/8 (9.5)	3/8 (9.5)	3/8 (9.5)	3/8 (9.5)	3/8 (9.5)
Face Area, ft ² (m ²)	30 (2.79)	30 (2.79)	30 (2.79)	29 (2.69)	29 (2.69)
Rows	2	2	2	3	3
FPI	14	14	14	12	12
Indoor Coil					
Type	High-Performance	High-Performance	High-Performance	High-Performance	High-Performance
Tube Size—OD, in. (mm)	3/8 (9.5)	3/8 (9.5)	3/8 (9.5)	3/8 (9.5)	3/8 (9.5)
Face Area, ft ² (m ²)	10 (0.93)	10 (0.93)	10 (0.93)	17 (1.58)	17 (1.58)
Rows	6	6	6	6	6
FPI	14	14	14	14	14
Refrigerant Control	TXV	TXV	TXV	TXV	TXV
Drain Connection Number	1	1	1	1	1
Drain Connection Size, in. (mm)	1 (25.4)	1 (25.4)	1 (25.4)	1 (25.4)	1 (25.4)
Outdoor Fan					
Type	Propeller	Propeller	Propeller	Propeller	Propeller
Number Used	2	2	2	3	3
Diameter, in. (mm)	27 (685.8)	27 (685.8)	27 (685.8)	27 (685.8)	27 (685.8)
Drive Type	Direct	Direct	Direct	Direct	Direct
No. Speeds	1	1	1	1	1
Fan cfm (m ³ /h)	7,000 (11,893)	7,000 (11,893)	7,000 (11,893)	7,000 (11,893)	7,000 (11,893)
Number Motors	2	2	2	3	3
Motor HP (kW), per motor	1.0 (0.75)	1.0 (0.75)	1.0 (0.75)	1.0 (0.75)	1.0 (0.75)
Motor RPM	1,140	1,140	1,140	1,140	1,140
Indoor Fan					
Type	Airfoil	Airfoil	Airfoil	Airfoil	Airfoil
Number Used	1	1	1	1	1
Diameter, in. (mm)	Varies	Varies	Varies	Varies	Varies
Drive Type	Direct Drive	Direct Drive	Direct Drive	Direct Drive	Direct Drive
Number Motors	1	1	1	1	1
Motor HP (kW)	1–7.5 (0.75–5.59)	1–7.5 (0.75–5.59)	1–7.5 (0.75–5.59)	1–7.5 (0.75–5.59)	1–7.5 (0.75–5.59)
Motor RPM	1750–3500	1750–3500	1750–3500	1750–3500	1750–3500
Motor Frame Size	Varies	Varies	Varies	Varies	Varies
Filters					
Type Furnished	Refer to "OAU Filter Guide" in "Appendix," p. 53	Refer to "OAU Filter Guide" in "Appendix," p. 53	Refer to "OAU Filter Guide" in "Appendix," p. 53	Refer to "OAU Filter Guide" in "Appendix," p. 53	Refer to "OAU Filter Guide" in "Appendix," p. 53
Number Size Recommended					



General Data

Table 3. General Data—Cooling 40–80 Tons High Efficiency

	40 Tons Downflow	45 Tons Downflow	50 Tons Downflow	55 Tons Downflow	60 Tons Downflow	70 Tons Downflow	80 Tons Downflow
	OANG040	OANG045	OANG050	OANG055	OANG060	OANG070	OANG080
Cooling Performance (6-row)							
Gross Cooling Capacity, Btu (kW)	511,968 (150.04)	569,546 (166.92)	604,728 (177.23)	686,668 (201.24)	752,012 (220.39)	871,572 (255.43)	998,910 (292.75)
Nominal cfm (m ³ /h)	7,500 (12,743)	6,750 (11,468)	7,500 (12,743)	8,250 (14,017)	9,000 (15,291)	10,500 (17,840)	12,000 (20,388)
Cooling Performance (4-row)							
Gross Cooling Capacity, Btu (kW)	488,728 (143.23)	553,912 (162.34)	605,568 (177.47)	642,968 (188.44)	701,308 (205.53)	847,228 (248.30)	924,696 (271.00)
Nominal cfm (m ³ /h)	12,800 (21,747)	14,400 (24,466)	16,000 (27,184)	17,600 (29,903)	19,200 (32,621)	22,400 (38,058)	25,000 (42,475)
Compressor							
Number	4	4	4	4	4	4	4-6
Type	Scroll	Scroll	Scroll	Scroll	Scroll	Scroll	Scroll
Outdoor Coil							
Type	High-Performance	High-Performance	High-Performance	High-Performance	High-Performance	High-Performance	High-Performance
Tube Size—OD, in. (mm)	3/8 (9.5)	3/8 (9.5)	3/8 (9.5)	3/8 (9.5)	3/8 (9.5)	3/8 (9.5)	3/8 (9.5)
Face Area, ft ² (m ²)	30 (2.79)	30 (2.79)	30 (2.79)	48 (4.46)	48 (4.46)	48 (4.46)	48 (4.46)
Rows	3	3	3	3	3	3	3
FPI	14	14	14	14	14	14	14
Indoor Coil							
Type	High-Performance	High-Performance	High-Performance	High-Performance	High-Performance	High-Performance	High-Performance
Tube Size (6-row)—OD, in. (mm)	1/2 (12.7)	1/2 (12.7)	1/2 (12.7)	1/2 (12.7)	1/2 (12.7)	1/2 (12.7)	1/2 (12.7)
Tube Size (4-row)—OD, in. (mm)	3/8 (9.5)	3/8 (9.5)	3/8 (9.5)	3/8 (9.5)	3/8 (9.5)	3/8 (9.5)	3/8 (9.5)
Face Area (6-row), ft ² (m ²)	26 (2.42)	26 (2.42)	26 (2.42)	34 (3.16)	34 (3.16)	34 (3.16)	34 (3.16)
Face Area (4-row), ft ² (m ²)	34 (3.16)	34 (3.16)	34 (3.16)	2x21 (3.90)	2x21 (3.90)	2x21 (3.90)	2x21 (3.90)
Rows	6 or 4	6 or 4	6 or 4	6 or 4	6 or 4	6 or 4	6 or 4
FPI	14	14	14	14	14	14	14
Refrigerant Control	TXV	TXV	TXV	TXV	TXV	TXV	TXV
Drain Connection Number	1	1	1	1	1	1	1
Drain Connection Size, in. (mm)	1 (25.4)	1 (25.4)	1 (25.4)	1 (25.4)	1 (25.4)	1 (25.4)	1 (25.4)
Outdoor Fan							
Type	Propeller	Propeller	Propeller	Propeller	Propeller	Propeller	Propeller
Number Used	4	4	4	6	6	6	6
Diameter, in. (mm)	30 (762)	30 (762)	30 (762)	30 (762)	30 (762)	30 (762)	30 (762)
Drive Type	Direct	Direct	Direct	Direct	Direct	Direct	Direct
No. Speeds	1	1	1	1	1	1	1
Fan cfm (m ³ /h)	40,000 (67,960)	40,000 (67,960)	40,000 (67,960)	60,000 (101,941)	60,000 (101,941)	60,000 (101,941)	60,000 (101,941)
Number Motors	4	4	4	6	6	6	6
Motor HP (kW), per motor	1.5 (1.12)	1.5 (1.12)	1.5 (1.12)	1.5 (1.12)	1.5 (1.12)	1.5 (1.12)	1.5 (1.12)
Motor RPM	1,140	1,140	1,140	1,140	1,140	1,140	1,140
Indoor Fan							
Type	Backward Inclined	Backward Inclined	Backward Inclined	Backward Inclined	Backward Inclined	Backward Inclined	Backward Inclined
Number Used	1	1	1	1	1	1	1
Diameter, in. (mm)	Varies	Varies	Varies	Varies	Varies	Varies	Varies
Drive Type	Direct Drive	Direct Drive	Direct Drive	Direct Drive	Direct Drive	Direct Drive	Direct Drive

Table 3. General Data—Cooling 40–80 Tons High Efficiency (continued)

	40 Tons Downflow	45 Tons Downflow	50 Tons Downflow	55 Tons Downflow	60 Tons Downflow	70 Tons Downflow	80 Tons Downflow
	OANG040	OANG045	OANG050	OANG055	OANG060	OANG070	OANG080
Number Motors	1	1	1	1	1	1	1
Motor HP (kW) (Standard/ Oversized)	1.5–20 (1.12–14.91)	1.5–20 (1.12–14.91)	1.5–20 (1.12–14.91)	1.5–20 (1.12–14.91)	1.5–20 (1.12–14.91)	1.5–20 (1.12–14.91)	1.5–20 (1.12–14.91)
Motor RPM (Standard/ Oversized)	1750–3500	1750–3500	1750–3500	1750–3500	1750–3500	1750–3500	1750–3500
Motor Frame Size (Standard/Oversized)	Varies	Varies	Varies	Varies	Varies	Varies	Varies
Filters							
Type Furnished	Refer to "OAU Filter Guide" in	Refer to "OAU Filter Guide" in	Refer to "OAU Filter Guide" in	Refer to "OAU Filter Guide" in	Refer to "OAU Filter Guide" in	Refer to "OAU Filter Guide" in	Refer to "OAU Filter Guide" in
Number Size Recommended	"Appendix," p. 53	"Appendix," p. 53	"Appendix," p. 53	"Appendix," p. 53	"Appendix," p. 53	"Appendix," p. 53	"Appendix," p. 53

Table 4. General Data—ASHP 40–80 Tons High Efficiency

	40 Tons Downflow	45 Tons Downflow	50 Tons Downflow	55 Tons Downflow	60 Tons Downflow	70 Tons Downflow	80 Tons Downflow
	OANG040	OANG045	OANG050	OANG055	OANG060	OANG070	OANG080
Cooling Performance							
Gross Cooling Capacity, Btu (kW)	495,304 (145.16)	558,120 (163.57)	577,584 (169.27)	670,550 (196.52)	719,942 (210.99)	842,536 (246.92)	928,964 (272.25)
Gross Heating Capacity, Btu (kW)	460,464 (134.95)	522,116 (153.02)	568,292 (166.55)	632,996 (185.51)	648,720 (190.12)	774,200 (226.90)	876,054 (256.75)
Nominal cfm (m ³ /h)	5,000–10,000 (8,495–16,990)	5,625–11,250 (9,557–19,114)	6,250–12,500 (10,619–21,238)	6,875–13,750 (11,681–23,361)	7,500–15,000 (12,743–25,485)	8,750–17,500 (14,866–29,733)	10,000–20,000 (16,990–33,980)
Compressor							
Number	4	4	4	4	4	4	5
Type	Scroll	Scroll	Scroll	Scroll	Scroll	Scroll	Scroll
Outdoor Coil							
Type	High- Performance	High- Performance	High- Performance	High- Performance	High- Performance	High- Performance	High- Performance
Tube Size—OD, in. (mm)	3/8 (9.5)	3/8 (9.5)	3/8 (9.5)	3/8 (9.5)	3/8 (9.5)	3/8 (9.5)	3/8 (9.5)
Face Area, ft ² (m ²)	45 (2.79)	45 (2.79)	45 (2.79)	45 (2.69)	45 (2.69)	45 (2.69)	45 (2.69)
Rows	2	2	2	2	2	3	3
FPI	14	14	14	14	14	14	14
Indoor Coil							
Type	High- Performance	High- Performance	High- Performance	High- Performance	High- Performance	High- Performance	High- Performance
Tube Size—OD, in. (mm)	1/2 (9.5)	1/2 (9.5)	1/2 (9.5)	1/2 (9.5)	1/2 (9.5)	1/2 (9.5)	1/2 (9.5)
Face Area, ft ² (m ²)	26 (0.93)	26 (0.93)	26 (0.93)	26 (1.58)	34 (1.58)	34 (1.58)	34 (1.58)
Rows	6	6	6	6	6	6	6
FPI	14	14	14	14	14	14	14
Refrigerant Control	TXV	TXV	TXV	TXV	TXV	TXV	TXV
Drain Connection Number	1	1	1	1	1	1	1
Drain Connection Size, in. (mm)	1 (25.4)	1 (25.4)	1 (25.4)	1 (25.4)	1 (25.4)	1 (25.4)	1 (25.4)
Outdoor Fan							
Type	Propeller	Propeller	Propeller	Propeller	Propeller	Propeller	Propeller
Number Used	4	4	4	6	6	6	6
Diameter, in. (mm)	30 (685.8)	30 (685.8)	30 (685.8)	30 (685.8)	30 (685.8)	30 (685.8)	30 (685.8)
Drive Type	Direct	Direct	Direct	Direct	Direct	Direct	Direct
No. Speeds	1	1	1	1	1	1	1
Fan cfm (m ³ /h)	40,000 (67,960)	40,000 (67,960)	40,000 (67,960)	60,000 (101,941)	60,000 (101,941)	60,000 (101,941)	60,000 (101,941)



General Data

Table 4. General Data—ASHP 40–80 Tons High Efficiency (continued)

	40 Tons Downflow	45 Tons Downflow	50 Tons Downflow	55 Tons Downflow	60 Tons Downflow	70 Tons Downflow	80 Tons Downflow
	OANG040	OANG045	OANG050	OANG055	OANG060	OANG070	OANG080
Number Motors	6	6	6	6	6	6	6
Motor HP (kW), per motor	1.5 (1.12)	1.5 (1.12)	1.5 (1.12)	1.5 (1.12)	1.5 (1.12)	1.5 (1.12)	1.5 (1.12)
Motor RPM	1,140	1,140	1,140	1,140	1,140	1,140	1,140
Indoor Fan							
Type	Backward Inclined	Backward Inclined	Backward Inclined	Backward Inclined	Backward Inclined	Backward Inclined	Backward Inclined
Number Used	1	1	1	1	1	1	1
Diameter, in. (mm)	Varies	Varies	Varies	Varies	Varies	Varies	Varies
Drive Type	Direct Drive	Direct Drive	Direct Drive	Direct Drive	Direct Drive	Direct Drive	Direct Drive
Number Motors	1	1	1	1	1	1	1
Motor HP (kW) (Standard/ Oversized)	1.5–20 (1.12–14.91)	1.5–20 (1.12–14.91)	1.5–20 (1.12–14.91)	1.5–20 (1.12–14.91)	1.5–20 (1.12–14.91)	1.5–20 (1.12–14.91)	1.5–20 (1.12–14.91)
Motor RPM (Standard/ Oversized)	1750–3500	1750–3500	1750–3500	1750–3500	1750–3500	1750–3500	1750–3500
Motor Frame Size (Standard/Oversized)	Varies	Varies	Varies	Varies	Varies	Varies	Varies
Filters							
Type Furnished	Refer to "OAU Filter Guide" in	Refer to "OAU Filter Guide" in	Refer to "OAU Filter Guide" in	Refer to "OAU Filter Guide" in	Refer to "OAU Filter Guide" in	Refer to "OAU Filter Guide" in	Refer to "OAU Filter Guide" in
Number Size Recommended	"Appendix," p. 53	"Appendix," p. 53	"Appendix," p. 53	"Appendix," p. 53	"Appendix," p. 53	"Appendix," p. 53	"Appendix," p. 53



Unit Clearances, Curb Dimensions, and Dimensional Data

OAD Units

Unit Clearances

Figure 1. Installation clearances for units with no powered exhaust or ERV, in. (cm)

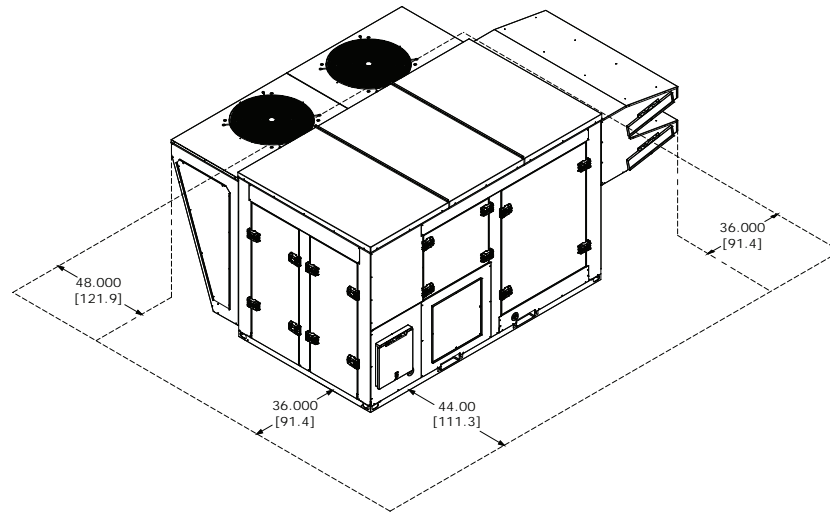
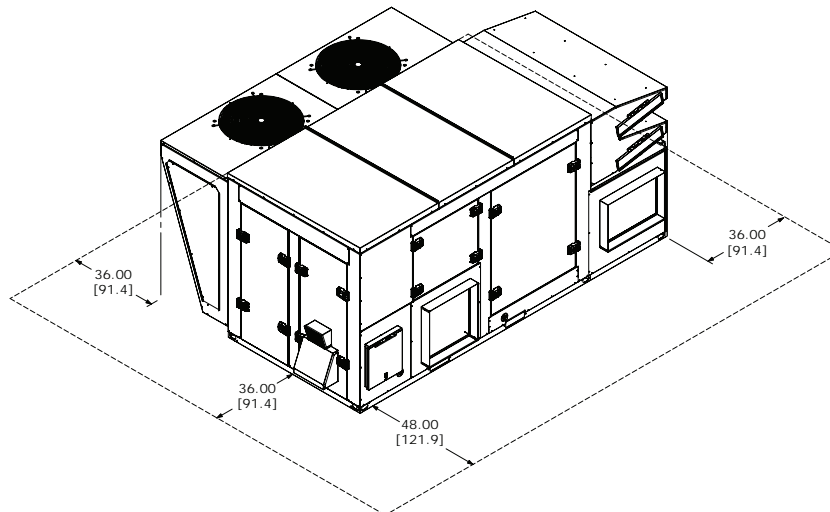

Figure 2. Installation clearances for unit with powered exhaust but no ERV, in. (cm)



Note: 72 in. (182.9 cm) clearance is required above the condenser fans.

Unit Clearances, Curb Dimensions, and Dimensional Data

Figure 3. Installation clearances for unit with ERV, in. (cm)

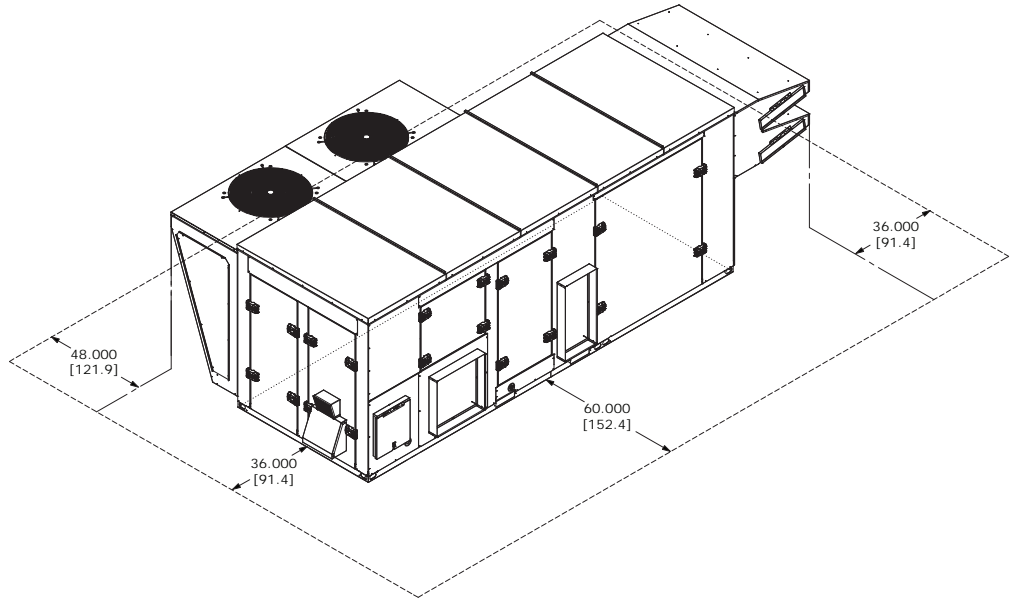

Note: 72 in. (182.9 cm) clearance is required above the condenser fans.

Figure 4. Unit to unit clearance, in. (cm)

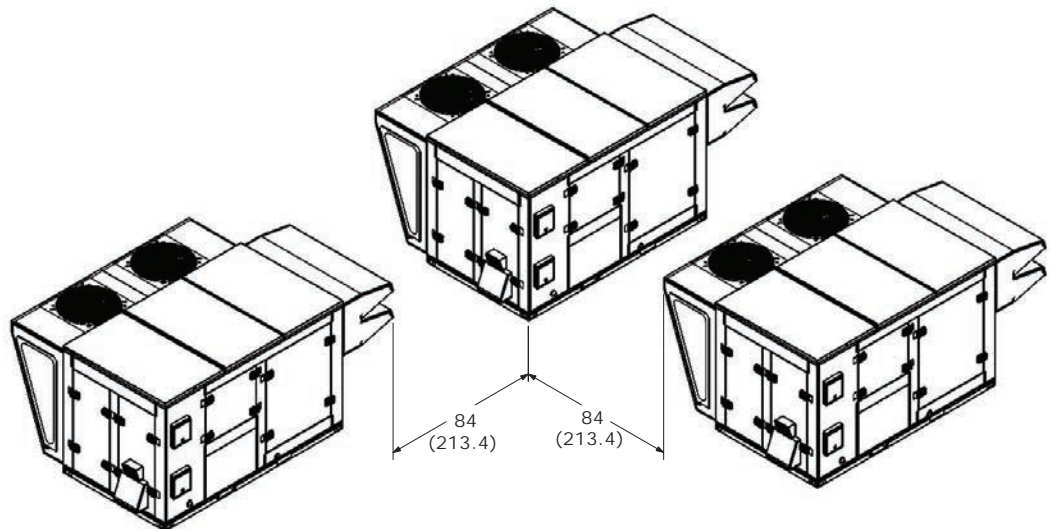

Unit Clearances, Curb Dimensions, and Dimensional Data

Curb Dimensions

Figure 5. Unit curb data for OAD cabinet with no powered exhaust or ERV, in. (cm)

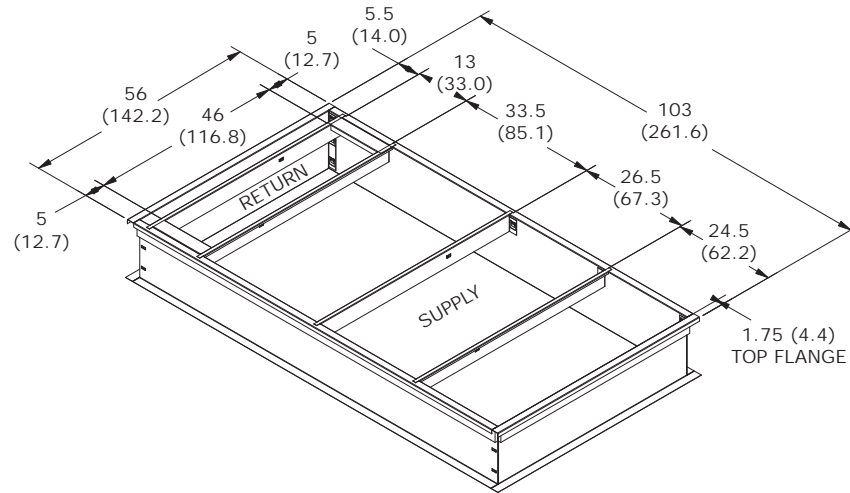
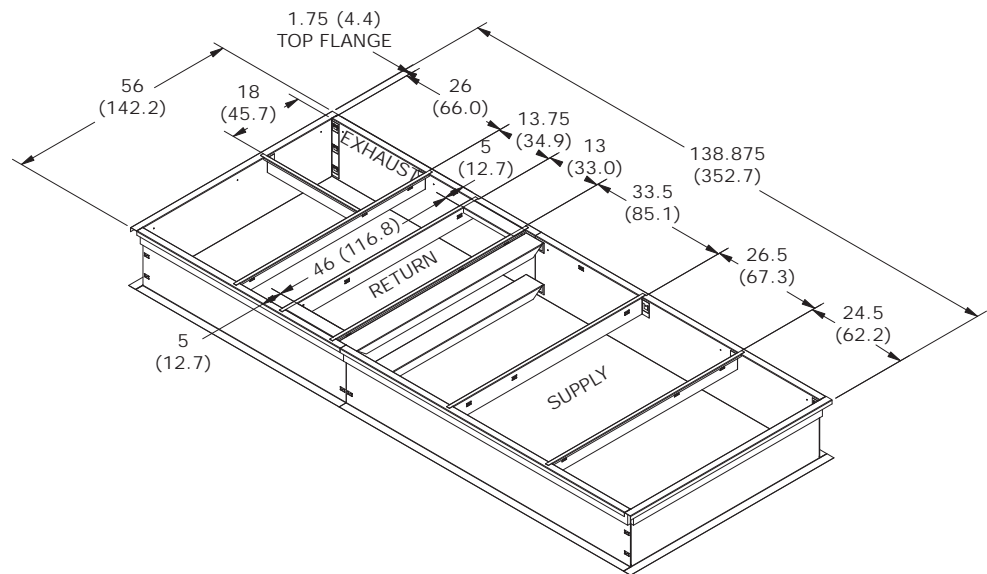

Figure 6. Unit curb data for OAD cabinet with powered exhaust but no ERV, in. (cm)



Unit Clearances, Curb Dimensions, and Dimensional Data

Notes:

- Sound attenuation package will add 16 in. (40.6 cm) to the height of the condenser fan section.
- Units with no cooling will have the same dimensions, less the condensing section.
- Units with chilled water cooling will have the same dimensions, less the condensing section, and with an 18 in. (25.4 cm) deep pipe cabinet added.
- Refer to project-specific unit submittals.

Figure 9. Unit dimensional data for OAD cabinet with powered exhaust but no ERV, in. (cm)

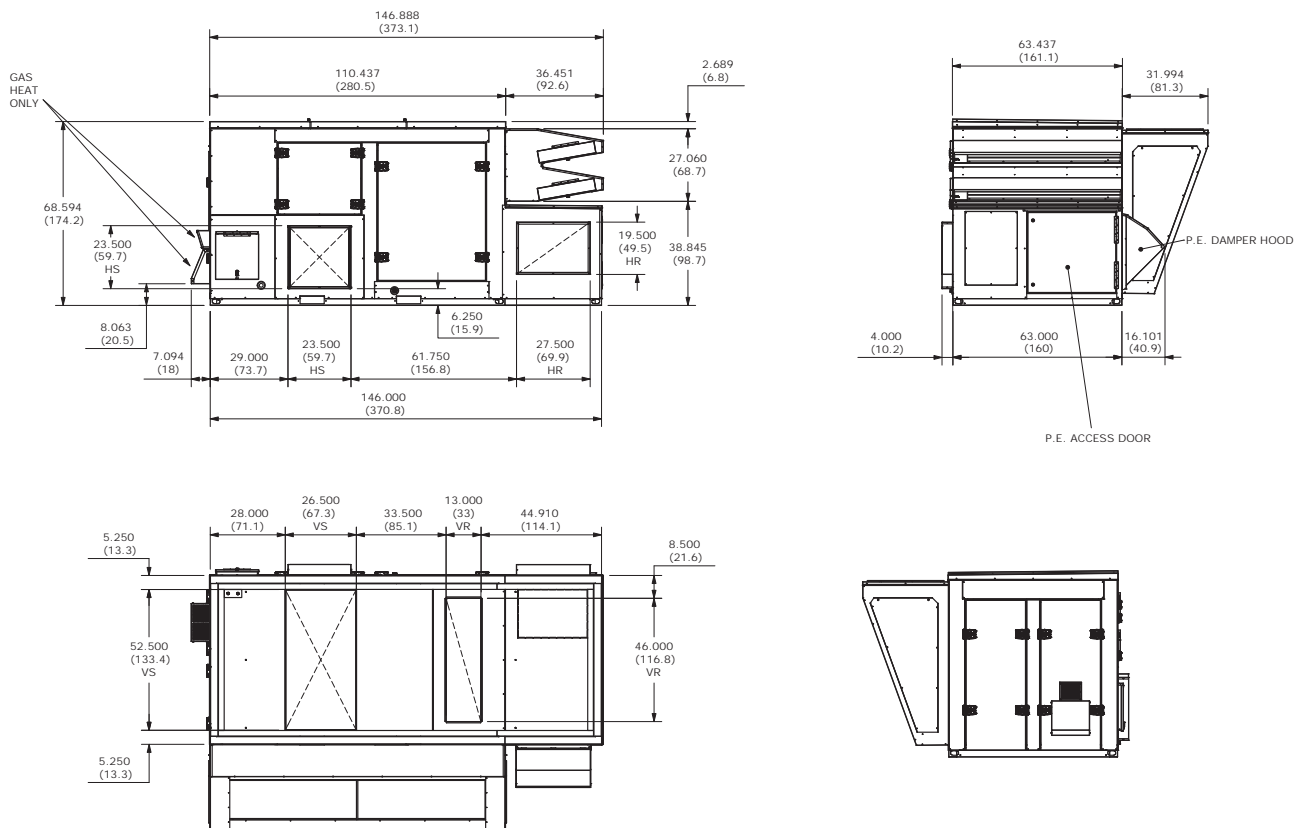

Notes:

- Sound attenuation package will add 16 in. (40.6 cm) to the height of the condenser fan section.
- Units with no cooling will have the same dimensions, less the condensing section.
- Units with chilled water cooling will have the same dimensions, less the condensing section, and with an 18 in. (45.7 cm) deep pipe cabinet added.
- Refer to project-specific unit submittals.

Unit Clearances, Curb Dimensions, and Dimensional Data

Figure 10. Unit dimensional data for OAD cabinet with ERV, in. (cm)

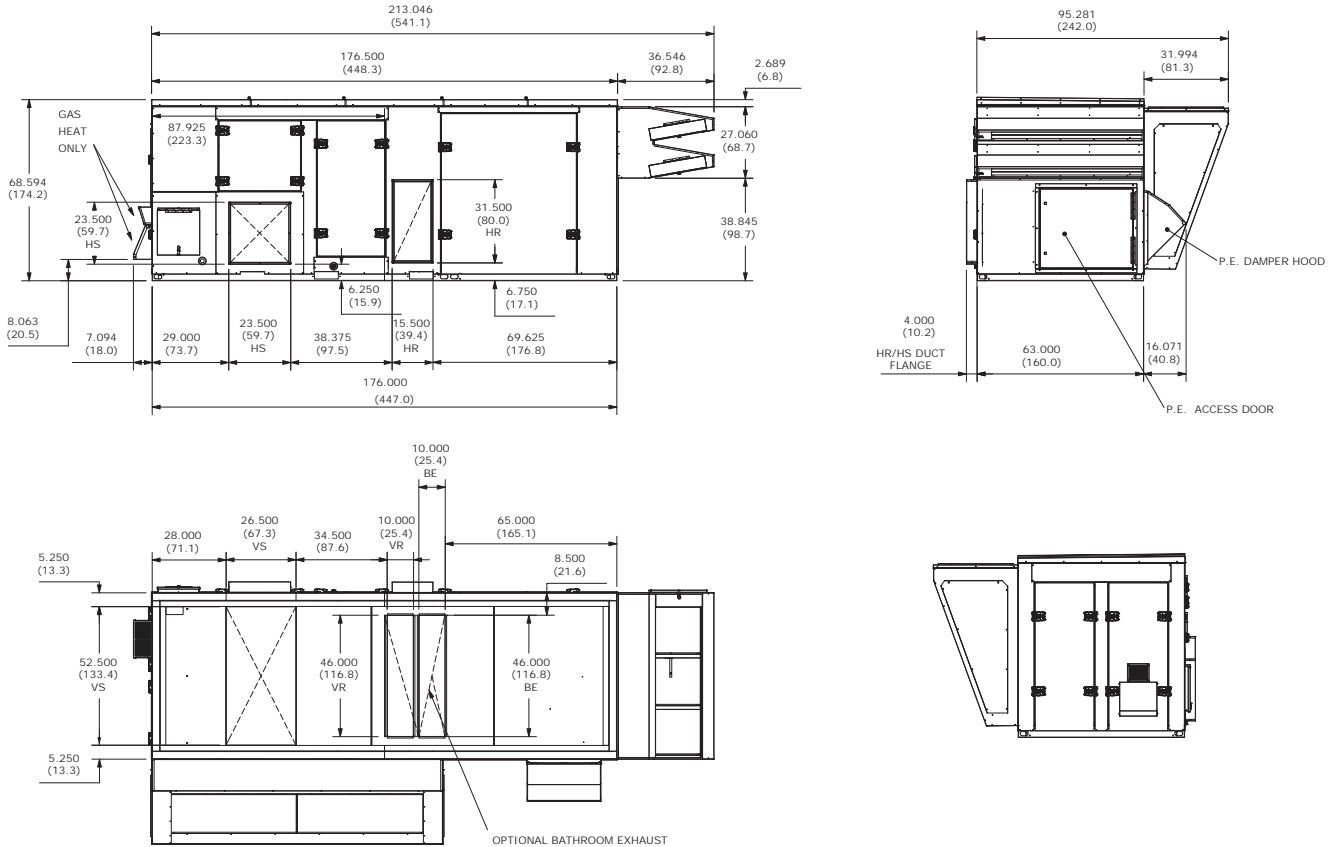

Notes:

- Sound attenuation package will add 16 in. (40.6 cm) to the height of the condenser fan section.
- Units with no cooling will have the same dimensions, less the condensing section.
- Units with chilled water cooling will have the same dimensions, less the condensing section, and with an 18 in. (45.7 cm) deep pipe cabinet added.
- Refer to project-specific unit submittals.

OAN Units

Unit Clearances

Figure 11. Installation clearances for units with no powered exhaust or ERV, in. (cm)

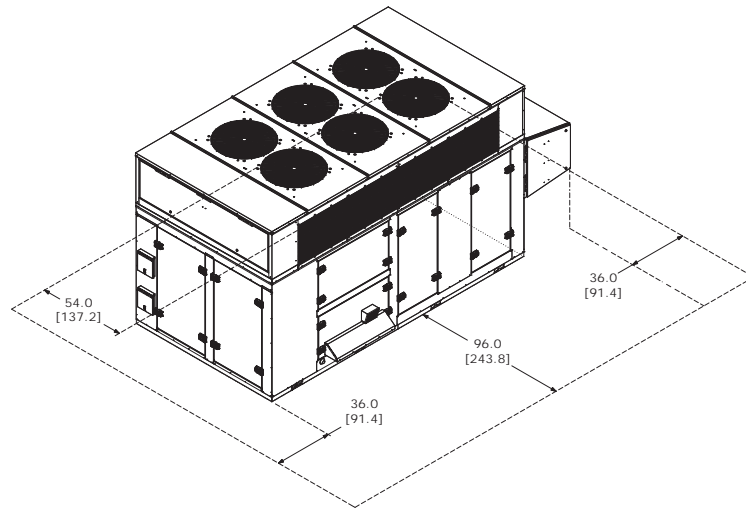
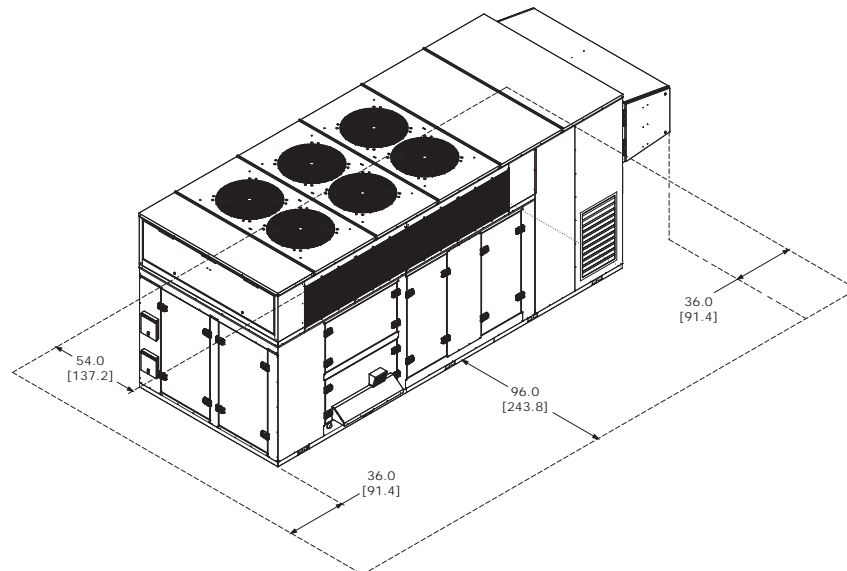

Figure 12. Installation clearances for unit with powered exhaust but no ERV, in. (cm)



Note: 72 in. (182.9 cm) clearance is required above the condenser fans.

Unit Clearances, Curb Dimensions, and Dimensional Data

Figure 13. Installation clearances for unit with ERV, in. (cm)

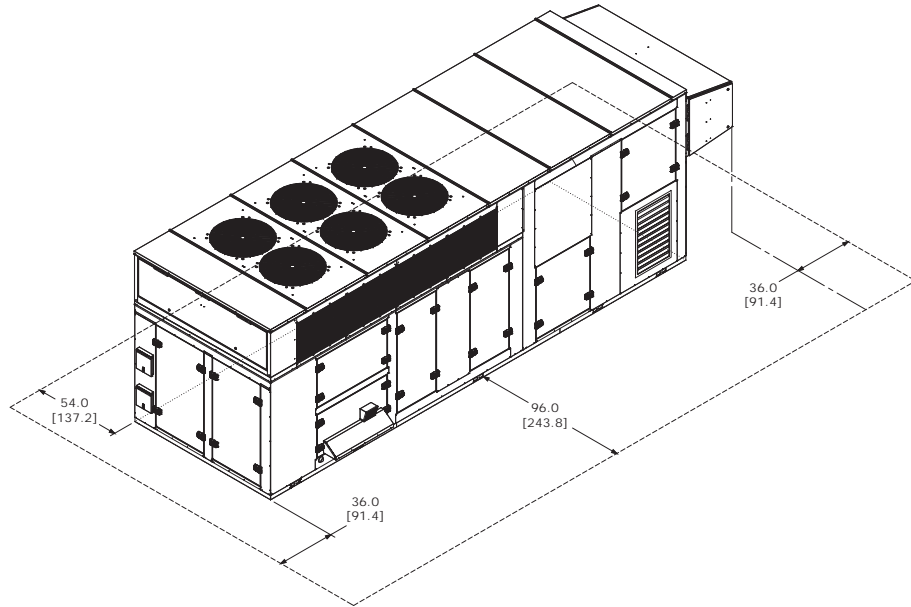

Note: 72 in. (182.9 cm) clearance is required above the condenser fans.

Figure 14. Unit to unit clearance, in. (cm)

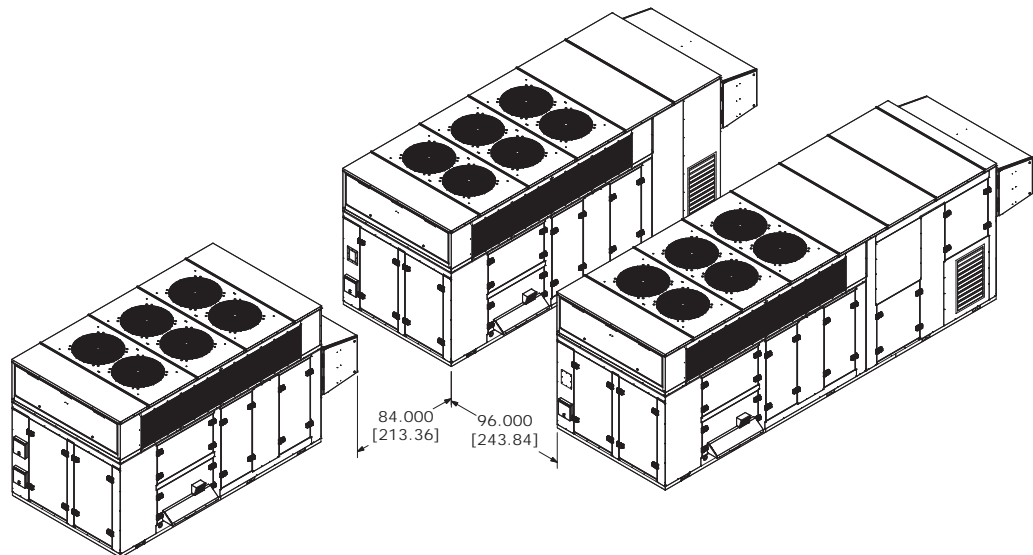

Unit Clearances, Curb Dimensions, and Dimensional Data

Curb Dimensions

Figure 15. Unit curb data for OAN cabinet with no powered exhaust or ERV, in. (cm)

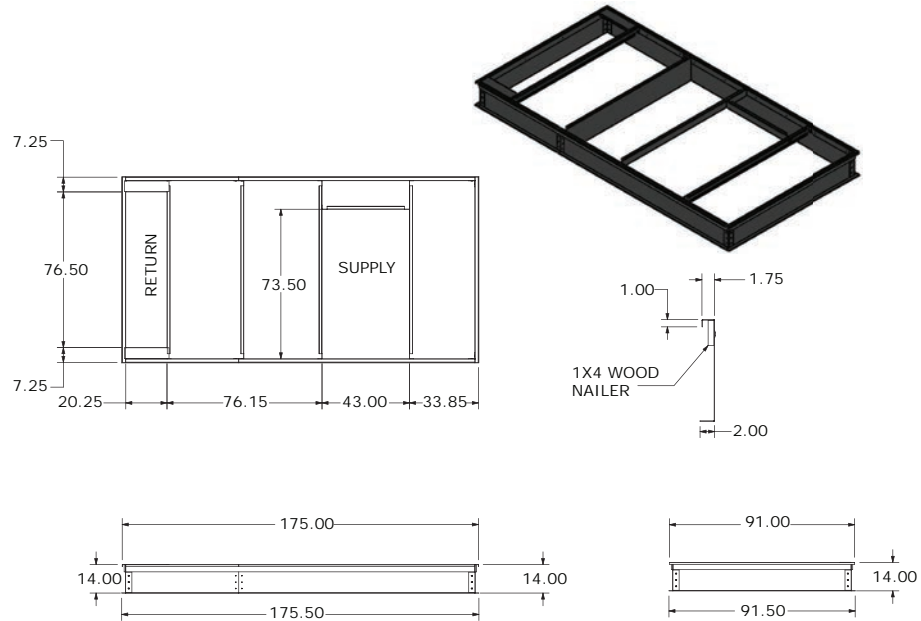
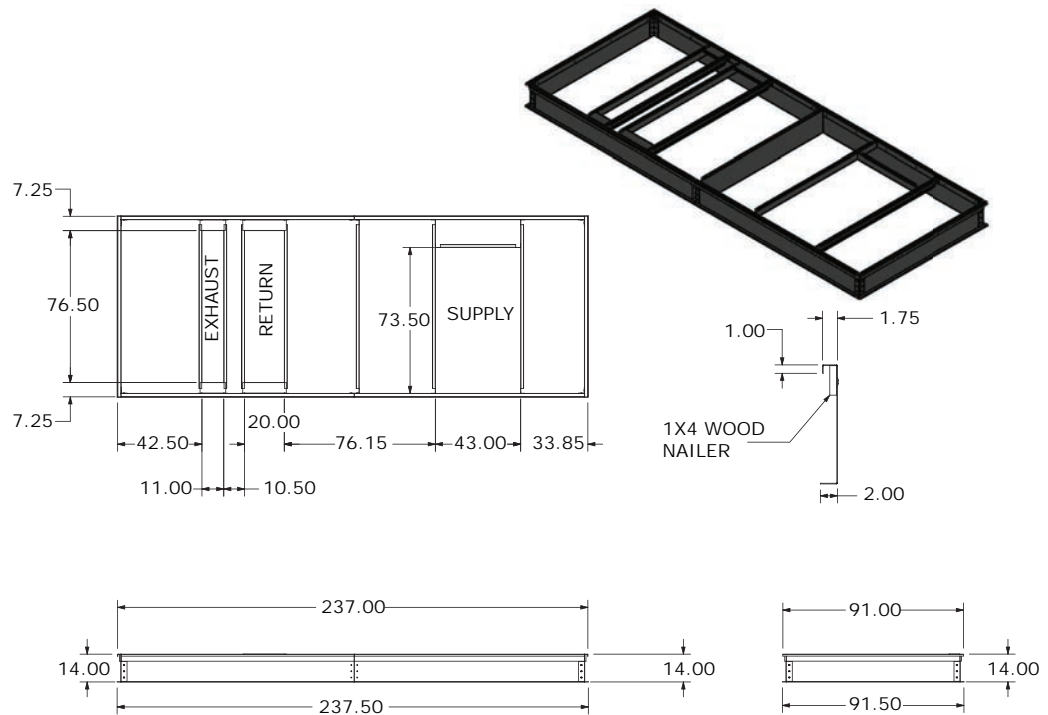
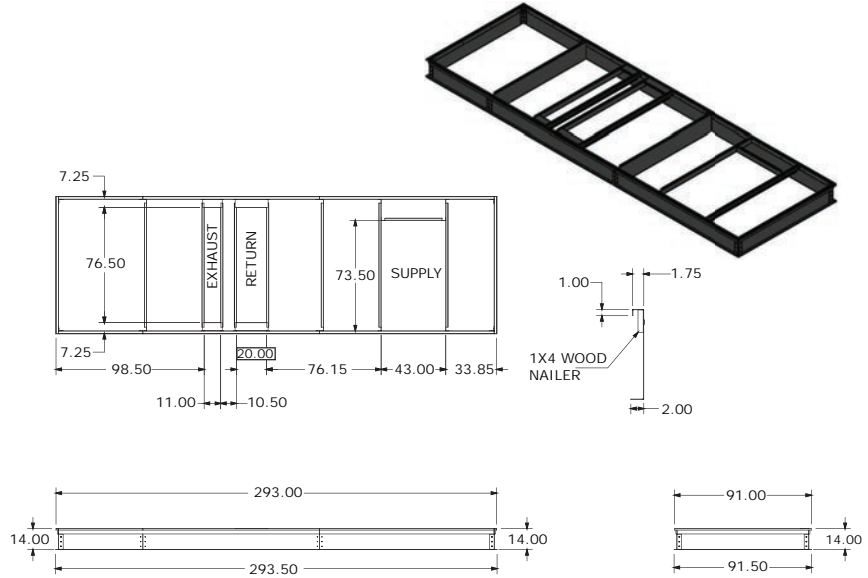

Figure 16. Unit curb data for OAN cabinet with powered exhaust but no ERV, in. (cm)



Unit Clearances, Curb Dimensions, and Dimensional Data

Figure 17. Unit curb data for OAN cabinet with ERV, in. (cm)



Dimensional Data

Figure 18. Unit dimensional data for OAN unit with no powered exhaust or ERV, in. (cm)

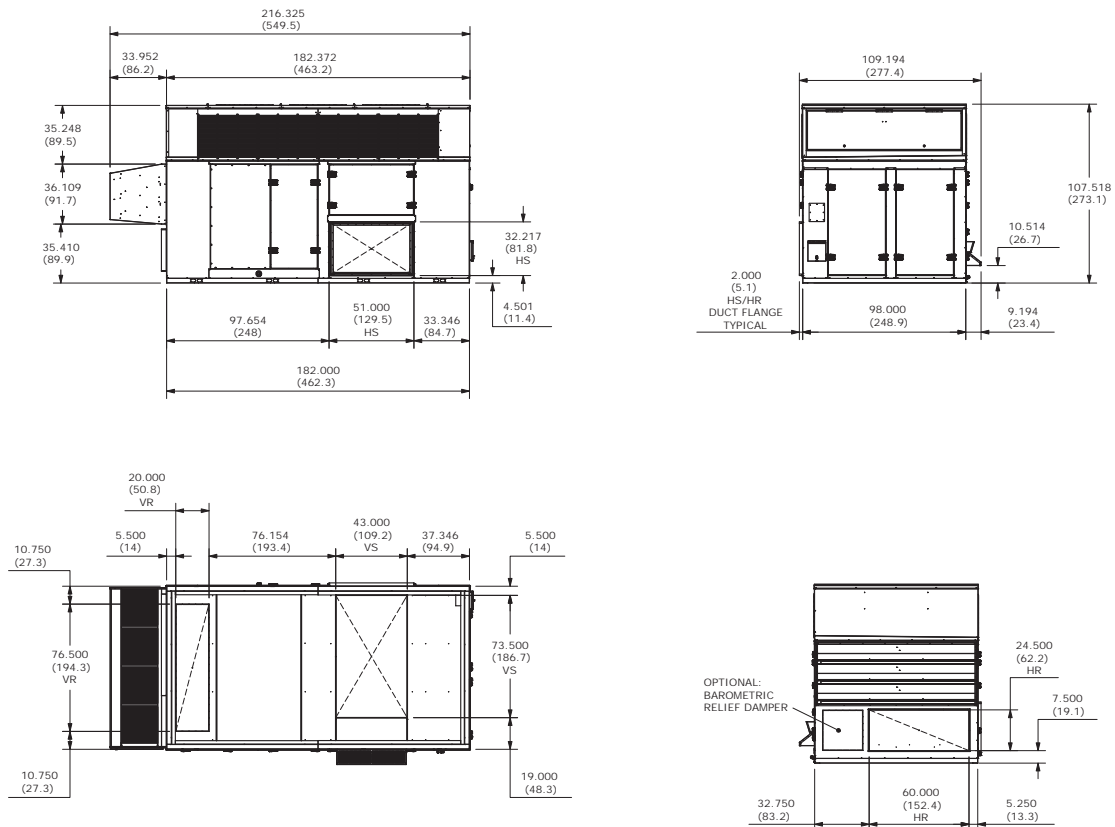

Unit Clearances, Curb Dimensions, and Dimensional Data

Notes:

- Units with no cooling will have the same dimensions, less the condensing section.
- Units with chilled water cooling will have the same dimensions, less the condensing section, and with an 18 in. (45.7 cm) deep pipe cabinet added.
- Refer to project-specific unit submittals.

Figure 19. Unit dimensional data for OAN cabinet with powered exhaust but no ERV, in. (cm)

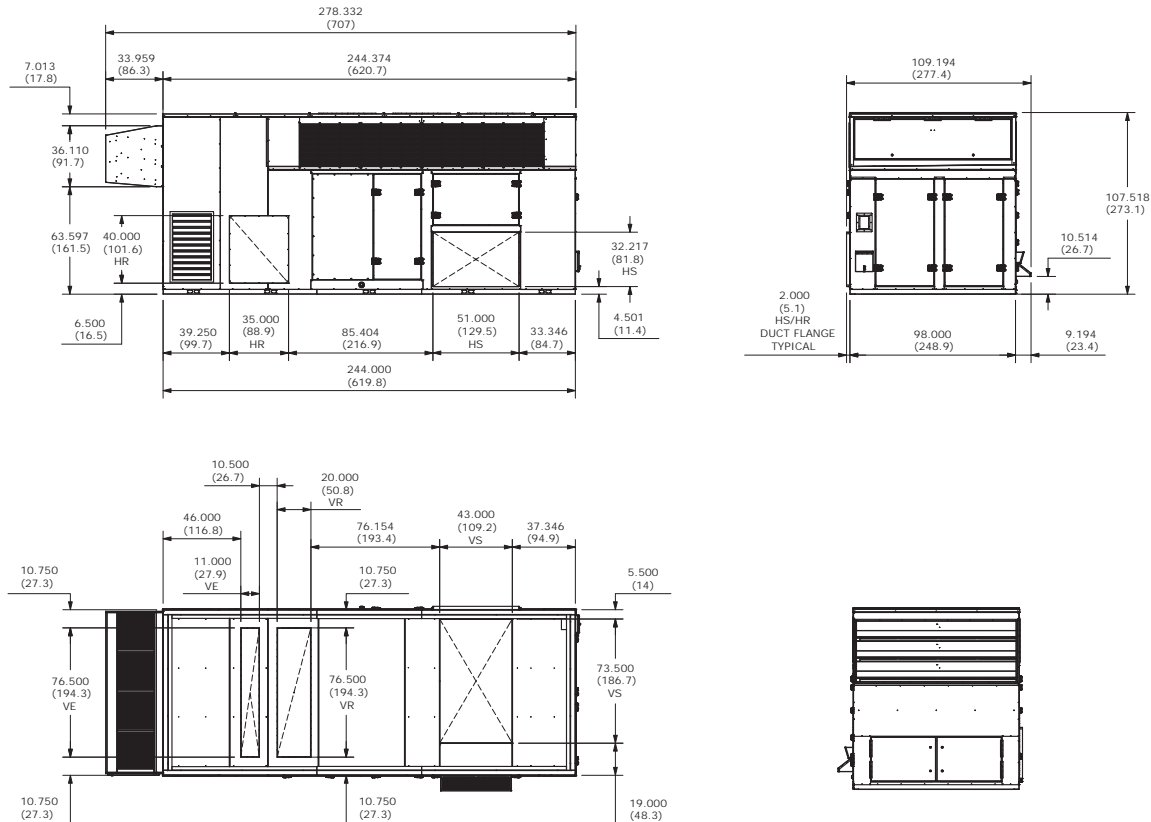

Notes:

- Units with no cooling will have the same dimensions, less the condensing section.
- Units with chilled water cooling will have the same dimensions, less the condensing section, and with an 18 in. (45.7 cm) deep pipe cabinet added.
- Refer to project-specific unit submittals.

Unit Clearances, Curb Dimensions, and Dimensional Data

Figure 20. Unit dimensional data for OAN cabinet with ERV, in. (cm)

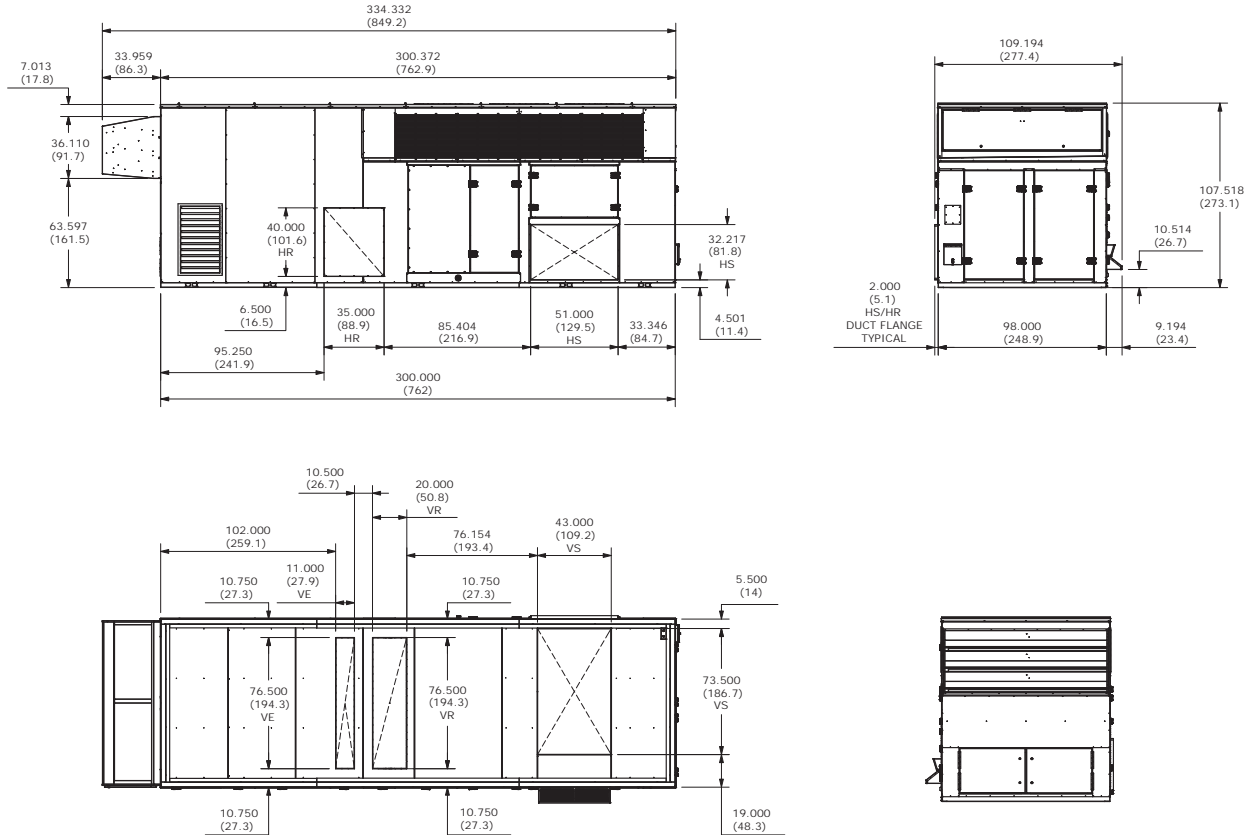

Notes:

- Units with no cooling will have the same dimensions, less the condensing section.
- Units with chilled water cooling will have the same dimensions, less the condensing section, and with an 18 in. (45.7 cm) deep pipe cabinet added.
- Refer to project-specific unit submittals.

Indirect Gas-fired Furnace Heater and Power

Figure 1. OAD indirect gas-fired furnace heater components

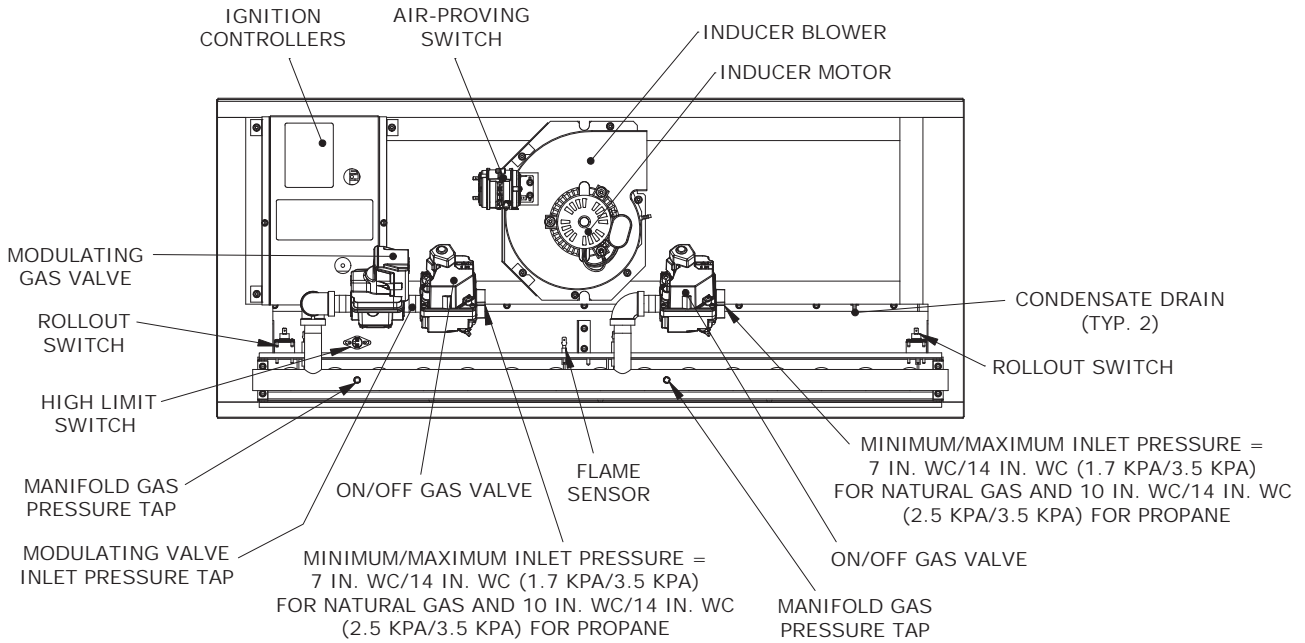
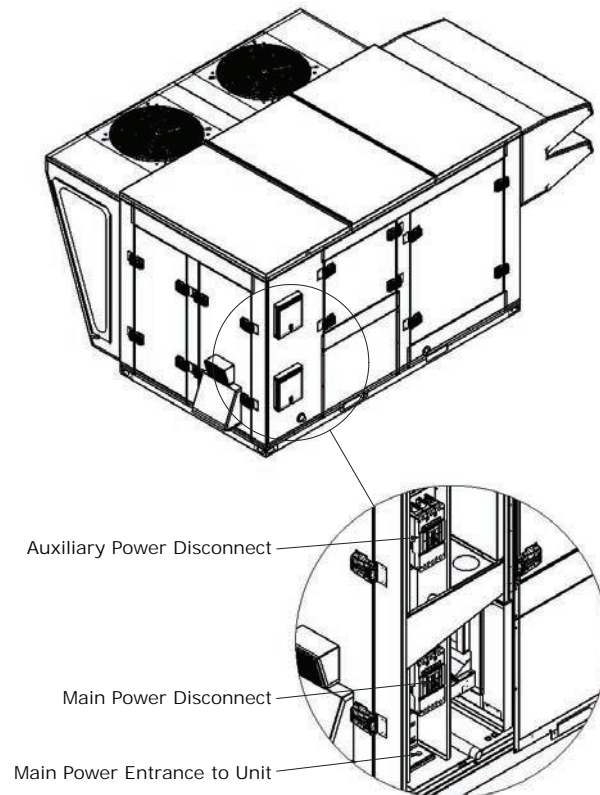
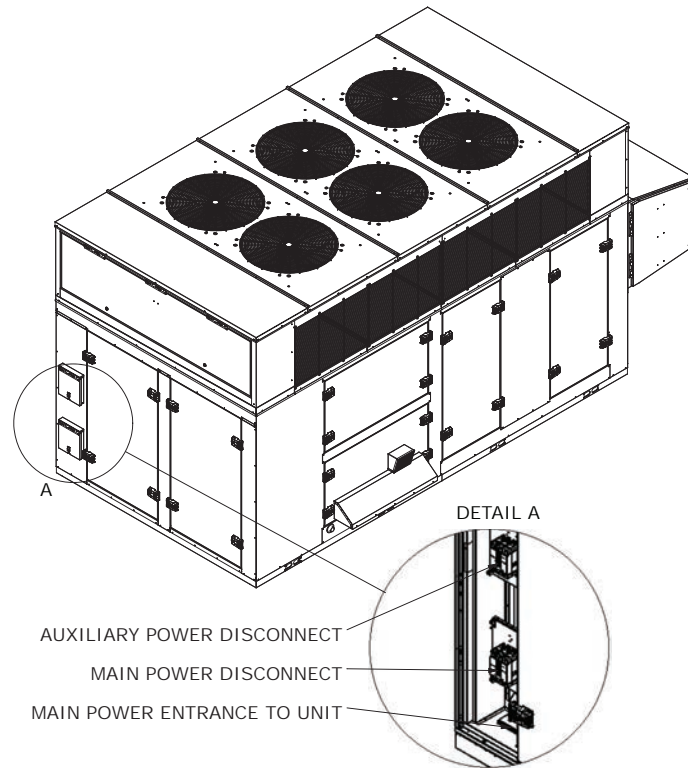

Figure 2. OAD power entrance



Indirect Gas-fired Furnace Heater and Power

Figure 3. OAN power entrance





Unit Weight and Rigging

Unit Weight

Table 1. Typical unit weight and center-of-gravity (CG)

Configuration	Tonnage	Operating Weight, lb (kg)		Center-of-gravity, in. (cm)	
		Minimum	Maximum	Length	Width
Standard Cabinet	OAD/No cooling/chilled water	1502 (681.3)	2492 (1130.4)	54.8 (139.2)	30.5 (77.5)
With Powered Exhaust	OAD/No cooling/chilled water	1677 (760.7)	2840 (1288.2)	64.5 (163.8)	31.8 (80.8)
With ERV	OAD/No cooling/chilled water	2347 (1064.6)	3911 (1774.0)	91.2 (231.6)	31.0 (78.7)
Standard Cabinet	OAD/10–15	2209 (1002.0)	3099 (1405.7)	50.5 (128.3)	41.2 (104.6)
With Powered Exhaust	OAD/10–15	2417 (1096.3)	3447 (1563.5)	58.4 (148.3)	41.1 (104.4)
With ERV	OAD/10–15	3099 (1405.7)	4519 (2049.8)	81.1 (206.0)	38.0 (96.5)
Standard Cabinet	OAD/17–20	2430 (1102.2)	3415 (1549.0)	49.8 (126.5)	41.0 (104.1)
With Powered Exhaust	OAD/17–20	2637 (1196.1)	3764 (1707.3)	57.1 (145.0)	41.0 (104.1)
With ERV	OAD/17–20	3320 (1505.9)	4835 (2193.1)	78.8 (200.2)	38.5 (97.8)
Standard Cabinet	OAN/No cooling	4266 (1935.0)	6085 (2760.1)	92.7 (235.5)	51.8 (131.6)
With Powered Exhaust	OAN/No cooling	5380 (2440.3)	7904 (3585.2)	135.2 (343.4)	50.4 (128.0)
With ERV	OAN/No cooling	6630 (3007.3)	9577 (4344.1)	169.4 (430.3)	49.5 (125.7)
Standard Cabinet	OAN/chilled water	4266 (1935.0)	6085 (2760.1)	94.5 (240.0)	51.3 (130.3)
With Powered Exhaust	OAN/chilled water	5380 (2440.3)	7904 (3585.2)	118 (299.8)	50.8 (129.0)
With ERV	OAN/chilled water	6630 (3007.3)	9577 (4344.1)	157.4 (399.8)	49.8 (126.5)
Standard Cabinet	OAN/40–50	6220 (2821.3)	8111 (3679.1)	87.2 (221.5)	50.1 (127.2)
With Powered Exhaust	OAN/40–50	7327 (3323.5)	9888 (4485.1)	106.8 (271.2)	49.9 (126.7)
With ERV	OAN/40–50	8536 (3871.9)	11563 (5244.9)	143.4 (364.2)	49.2 (124.9)
Standard Cabinet	OAN/55–60	6565 (2977.8)	8505 (3857.8)	91.4 (232.2)	50.2 (127.5)
With Powered Exhaust	OAN/55–60	7674 (3480.9)	10282 (4663.8)	115.9 (294.3)	49.9 (126.7)
With ERV	OAN/55–60	8883 (4029.3)	11957 (5423.6)	146.2 (371.3)	49.3 (125.2)
Standard Cabinet	OAN/70	6881 (3121.2)	8883 (4029.3)	96 (243.8)	50.5 (127.7)
With Powered Exhaust	OAN/70	7990 (3624.2)	10660 (4835.3)	120.5 (306.1)	50 (127.0)
With ERV	OAN/70	9199 (4172.6)	12335 (5595.1)	149.4 (397.5)	49.4 (125.5)
Standard Cabinet	OAN/80	7038 (3192.4)	9058 (4108.6)	95.6 (242.8)	50.7 (128.7)
With Powered Exhaust	OAN/80	8147 (3695.4)	10834 (4914.2)	125 (317.5)	50.5 (128.2)
With ERV	OAN/80	9356 (4243.8)	12510 (5674.4)	151.8 (385.6)	49.5 (125.7)

Rigging and Center-of-Gravity

Figure 1. Four-point lift (OAD cabinet with no exhaust fan or ERV)

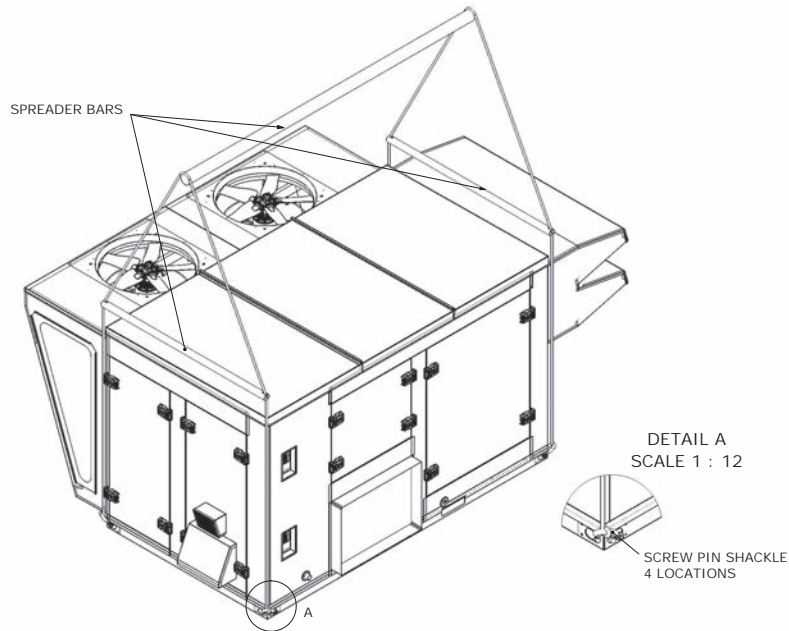

Figure 2. Four-point lift (OAD cabinet with exhaust fan and no ERV)

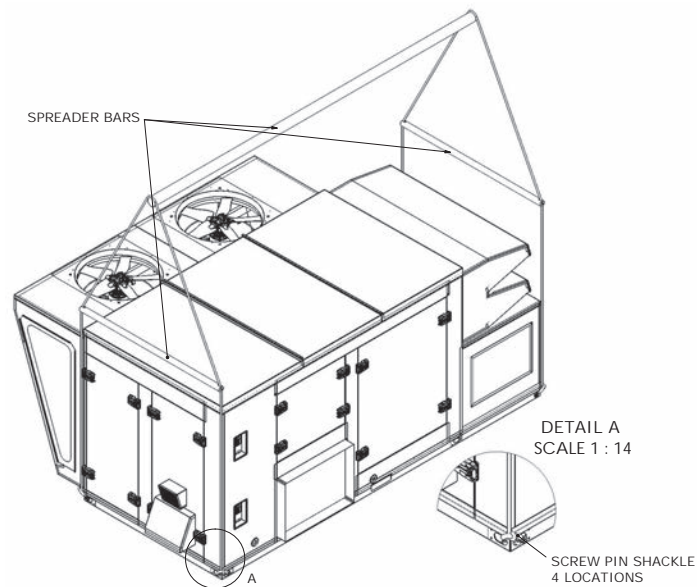

Figure 3. Six-point lift (OAD cabinet with ERV section)

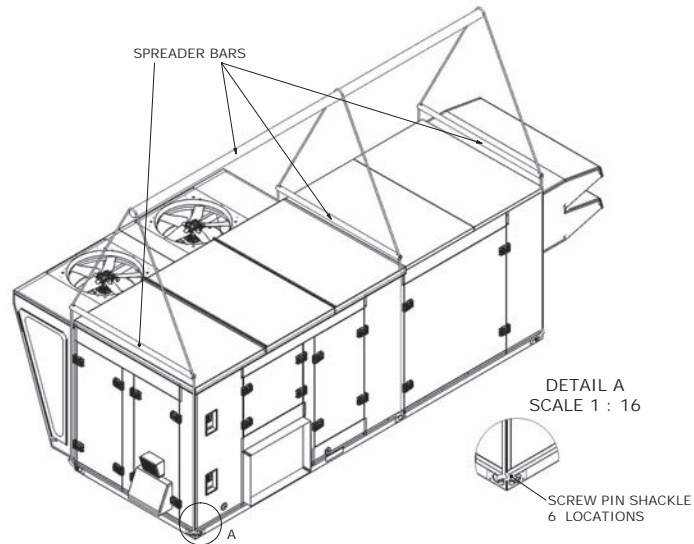

Figure 4. Eight-point lift (OAN cabinet with no exhaust fan or ERV)

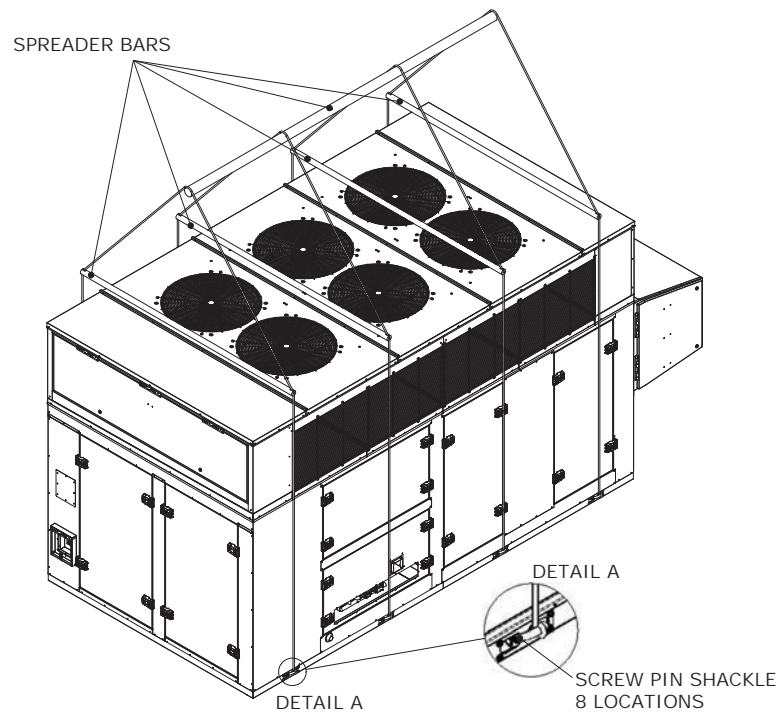

Figure 5. Ten-point lift (OAN cabinet with exhaust fan and no ERV)

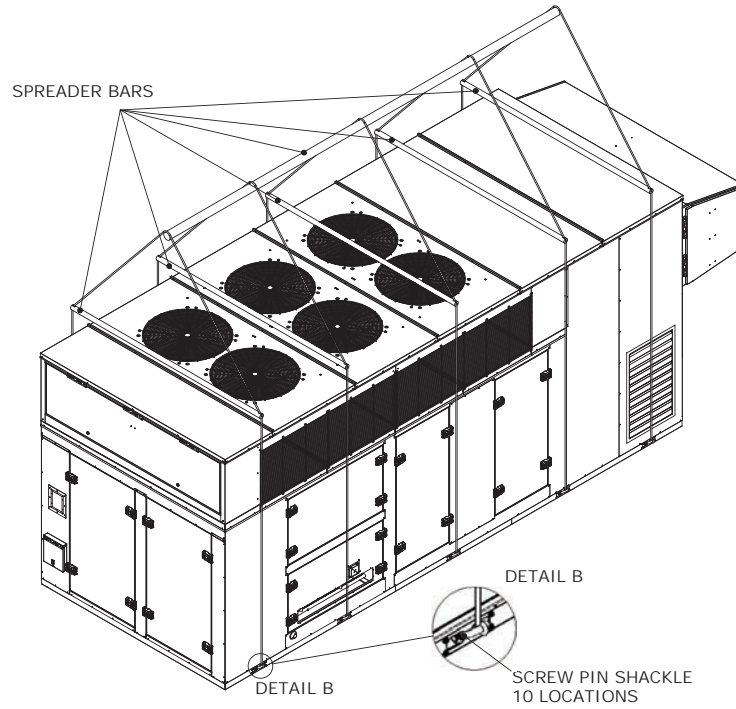
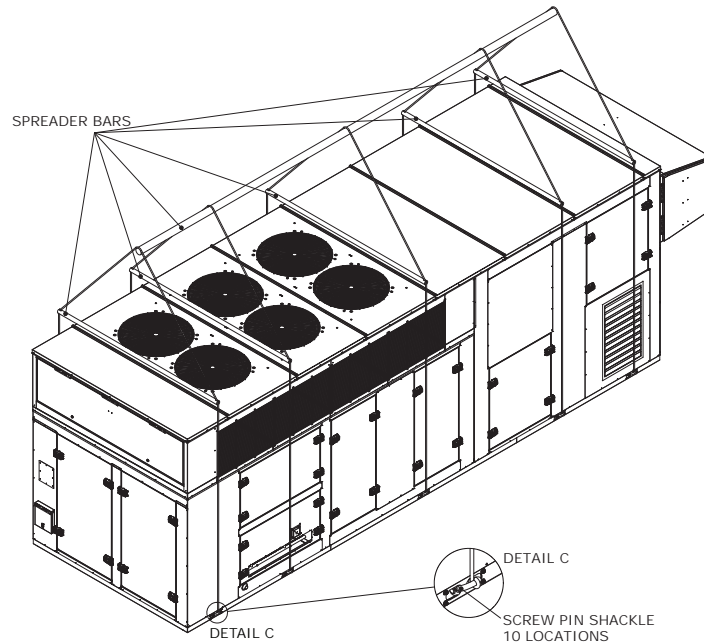

Figure 6. Ten-point lift (OAN cabinet with ERV)



For rigging instructions, please refer to OAU-SVX006*-EN (*Installation, Operation, and Maintenance: Horizon Outdoor Air Unit - Model: OADG*).



Mechanical Specifications

Horizon Outdoor Air Mechanical Specifications

General

The supply and return openings shall be available as vertical or horizontal airflow. Cooling performance shall be rated in accordance with ETL testing procedures. All units shall be factory assembled, internally wired, fully charged with R-410A, and 100 percent run tested to check cooling operation, fan and blower rotation, and control sequence before leaving the factory. Wiring internal to the unit shall be colored and numbered for simplified identification. Units shall be ETL listed and labeled, classified in accordance to UL 1995/CAN/CSA No. 236-M40 for Central Cooling Air Conditioners. Canadian units shall be CSA Certified.

Casing

Unit casing will be provided with a thermal break and shall be constructed of zinc-coated, heavy gauge, galvanized steel. Exterior surfaces shall be cleaned, phosphatized, and finished with a weather-resistant baked enamel finish. Unit's surface shall be tested 672 hours in a salt spray test in compliance with ASTM B117. Unit shall have a 2-in. thick Antimicrobial Insulation with an R-value of 13, including unit floor and roof panels. All insulation edges shall be either captured or sealed. The unit's base pan shall have no penetrations within the perimeter of the curb other than the raised downflow supply/return openings to provide an added water integrity precaution, if the condensate drain backs up. The top cover shall be one piece construction or, where seams exist, it shall be double-hemmed and gasket-sealed. The ribbed top adds extra strength and enhances water removal from unit top.

Drain Pan

The drain pan is a single-walled assembly made of Type 430 stainless steel. It is sloped in two planes and is fully drainable. The coils are mounted above the drain pan to allow easy inspection and cleaning of the drain pan.

Refrigeration and Dehumidification Systems

Compressors

All units shall have direct-drive, hermetic, scroll type compressors with centrifugal type oil pumps. Motor shall be suction gas-cooled and shall have a voltage utilization range of plus or minus 10 percent of unit nameplate voltage. Internal overloads shall be provided with the scroll compressors. Each compressor has a crankcase heater to minimize the amount of liquid refrigerant present in the oil sump during off cycles.

Mechanical Specifications

Evaporator and Condenser Coils

Refer to [Figure 1](#). Internally finned copper tubes mechanically bonded to a configured aluminum plate fin shall be standard. Coils shall be leak tested at the factory to ensure the pressure integrity. The evaporator coil and condenser coil shall be leak tested to 500 psig and pressure tested to 500 psig. The condenser coil shall have a fin design with slight gaps for ease of cleaning. Evaporator coil will have four or six interlaced rows for superior sensible and latent cooling.

Figure 1. Evaporator and reheat coil

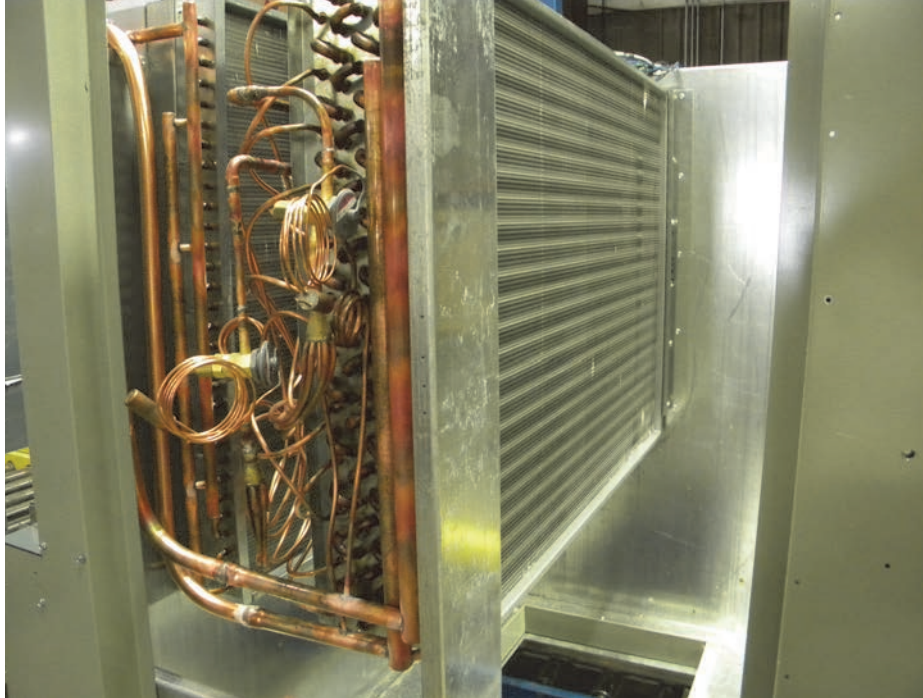

Chilled Water Coils

The chilled water coil is AHRI performance certified and shall bear the AHRI symbol. Tubes are to be mechanically expanded into fins (secondary surface) for maximum heat transfer and shall be 6 rows. Materials are to be 1/2 in. diameter x (0.020) wall thickness. Secondary surface (fins) shall be of the plate-fin design using aluminum with die-formed collars. Fin design is waffle in a staggered tube pattern to meet performance requirements. Collars will hold fin spacing at specified density, and cover the entire tube surface. Fins are to be free of oils and oxidation. The coil shall have MPT connections constructed of copper.

The optional Cooney Freeze Block is designed to allow ice to form within the tubes, without restriction, by discharging a small amount of water into the drain pan. Each expansion header has a factory installed Cooney Freeze Block Valve that is both pressure and thermally activated. The valve will open when outside air below 35°F comes in contact with the header or return end of the coil, or when the internal pressure of the coil exceeds 300 psi. The valve will automatically reset and allow the coil to resume normal operation, when the pressure decreases, or when the temperature increases.

Refrigerant Capacity Control

Units with standard scroll compressors shall be equipped with Refrigerant Capacity Control (RCC) on the lead circuit to ensure proper modulation of cooling. The RCC uses mechanical means to monitor and inject hot gas into the suction side of the compressor, unloading the compressor in part load conditions. The RCC is factory-set at 114 psig, which will maintain evaporator coil temperature at 38°F.

Units with eFlex™ variable speed scroll compressors are matched with a specially designed variable frequency drive that allows a modulating ratio of up to 4:1. This allows for unmatched control of leaving air temperatures to meet space loads. The eFlex compressors also include brushless permanent magnet motors designed to operate at higher efficiency resulting in significant part load energy savings. This makes units with eFlex technology the most efficient products in their class at part load.

Units with digital scroll type compressors shall have direct-drive, hermetic compressors with centrifugal type oil pumps. Motor shall be suction gas-cooled and shall have a voltage utilization range of plus or minus 10 percent of unit nameplate voltage. Internal overloads shall be provided with the scroll compressors. Crankcase heaters shall be included. Compressor shall be able to fully modulate from 20 percent to 100 percent.

Figure 2. Refrigerant capacity control

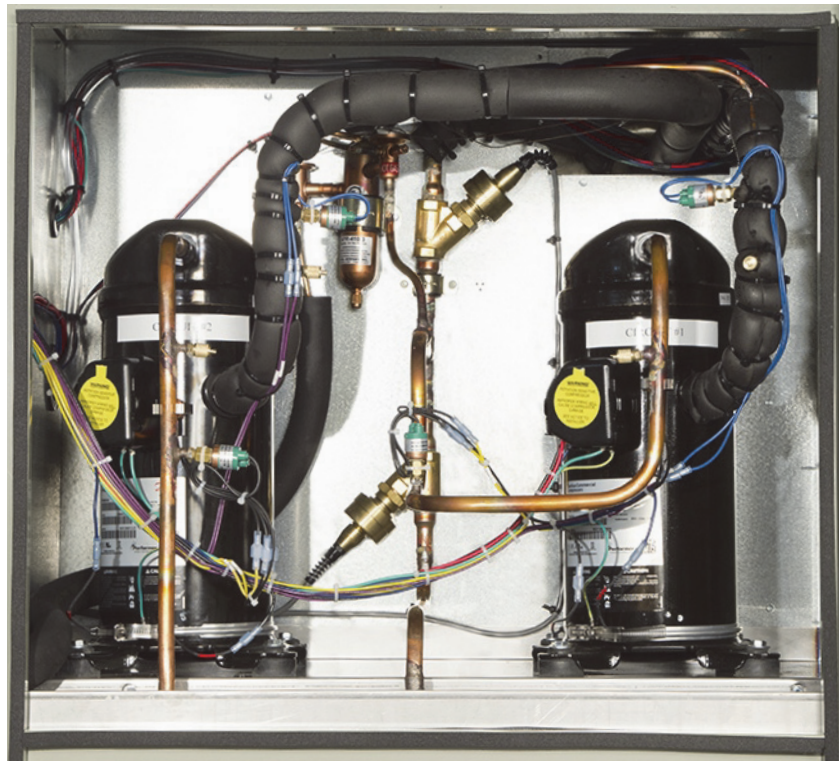

Mechanical Specifications

Total Energy Wheel (Composite)

The rotating wheel heat exchanger is composed of a rotating cylinder in an insulated cassette frame complete with seals, drive motor, and drive belt. The total-energy recovery wheel is coated with silica gel desiccant permanently bonded by a patented and proprietary process without the use of binders or adhesives, which may degrade desiccant performance. The substrate is a lightweight polymer and will not degrade nor require additional coatings for application in marine or coastal environments. Coated segments are washable with detergent or alkaline coil cleaner and water. Desiccant will not dissolve nor deliquesce in the presence of water or high humidity. As the wheel rotates between the ventilation and exhaust air streams it picks up sensible and latent heat energy and releases it into the colder air stream. The driving force behind the exchange is the difference in temperatures between the opposing air streams which is also called the thermal gradient. Bypass dampers will be provided on both the outside and exhaust air paths.

Total Energy Wheel (Aluminum)

The rotor media shall be lightweight and be made of aluminum. The rotor media shall be coated to prohibit corrosion; etched or oxidized surfaces are not acceptable. All surfaces must be coated with a non-migrating adsorbent layer of desiccant prior to being formed into the honeycomb media structure to insure that all surfaces are coated and that adequate latent capacity is provided. The desiccant must be designed for the adsorption of water vapor. The media shall be cleanable with low temperature steam, hot water or light detergent without degrading the latent recovery. Bypass dampers will be provided on both the outside and exhaust air paths.

Figure 3. Total-energy wheel module



Supply and Exhaust Fan and Motors

Fan motor shall be direct drive type with factory installed Variable Frequency Drive. All motors shall be thermally protected. All indoor fan motors meet the U.S. Energy Policy Act of 2005 (EPACT). Neoprene isolation pads will be provided under fan base. Refer to the following figure.

Figure 4. Indoor fan and motor

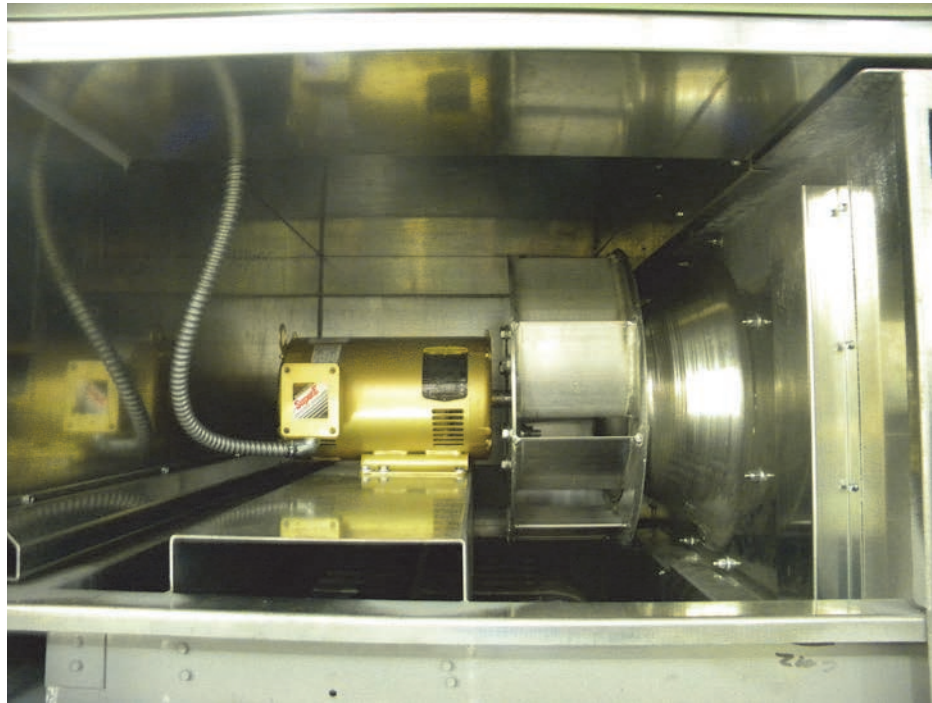

Condenser Fans and Motors

The outdoor fans shall be direct-drive, statically and dynamically balanced, draw-through in the vertical discharge position. The fan motor shall be permanently lubricated and shall have built-in thermal overload protection.

Dampers—Low Leak

The outside air damper has a unit-controlled actuator with parallel-blades. The blade construction is a 14-gage galvanized steel, roll-formed airfoil-type.

Electrical and Controls

Controls

Unit is completely factory-wired with necessary controls and contactor pressure lugs for power wiring. Units will provide an external location for mounting fused disconnect device. Micro-processor controls are provided for all 24-volt control functions. The resident control algorithms will make all heating, cooling and/or ventilating decisions in response to electronic signals from sensors measuring outdoor temperature and humidity. The control algorithm maintains accurate temperature control, minimizes drift from set point, and provides better building comfort. A centralized micro-processor (RTRM) will provide anti-short cycle timing for a higher level of machine protection. Terminals are provided for a field installed dry contact or switch closure to put the unit in the Occupied or Unoccupied modes.

Options**Electric Heating Option**

Primary heat is supplied using Electric Resistance heaters. Heaters shall meet the requirements of the National Electrical Code and shall be listed by Underwriters Laboratories for zero clearance to combustible surfaces and for use with heat pumps and air conditioning equipment. Heating elements shall be open coil, 80 percent nickel, 20 percent chromium, Grade A resistance wire. Type C alloys containing iron or other alloys are not acceptable. Coils shall be machine crimped into stainless steel terminals extending at least 1 in. into the air stream and all terminal hardware shall be stainless steel. Coils shall be supported by ceramic bushings staked into supporting brackets. Heater frames and terminal boxes shall be corrosion resistant steel. Unless otherwise indicated, the terminal box shall be NEMA 1 construction and shall be provided with a hinged, latching cover. Heaters shall be furnished with a disc type, automatic reset thermal cutout for primary over temperature protection. All heaters shall also be furnished with disc type, load-carrying manual reset thermal cutouts, factory wired in series with heater stages for secondary protection. Heat limiters or other fusible over temperature devices are not acceptable. Control will be SCR type. Unit shall be suitable for use with Electric Resistance Heat. Refer to the following figure.

Figure 5. ER Heater

**Indirect Gas-Fired Heating Option**

Primary heat is supplied using indirect fired gas heating. The heating section shall have a progressive tubular heat exchanger design using stainless steel burners and Type 409 stainless steel tubes. An induced draft combustion blower shall be used to pull the combustion products through the firing tubes. The heater shall use a direct spark ignition (DS) system. On initial call for heat, the combustion blower shall purge the heat exchanger for 20 seconds before ignition. After three unsuccessful ignition attempts, the entire heating system shall be locked out until manually reset at the unit. Units shall be comply with the California requirement for low NO_x emissions. Unit shall be suitable for use with Natural Gas.

Hydronic Heat Option

A factory installed one, two, or three row hydronic heating coil will be provided downstream of the fan. The unit controller provides a modulating output to control a factory-provided/field-installed water valve and accepts a low temperature limit input signal. Openings in the unit side panels for piping must also be field constructed.

Condenser Hot Gas Reheat

This option shall consist of a modulating hot-gas reheat coil located on the leaving air side of the evaporator coil pre-piped and circuited with a low pressure switch. For detailed unit control and operational modes, please refer to the "Sequence of Operations" in OAU-SVX006*-EN (*Installation, Operation, and Maintenance: Horizon Outdoor Air Unit - Model: OADG*).

Return Air

Air returns vertically through the unit base or horizontally through the cabinet. Dampers are low-leak. Each damper has a unit-controlled actuator. Inputs are provided for economizer control, based upon either comparative enthalpy or outside air and return air dry bulb conditions. Refer to the following figure.

Figure 6. Return air damper

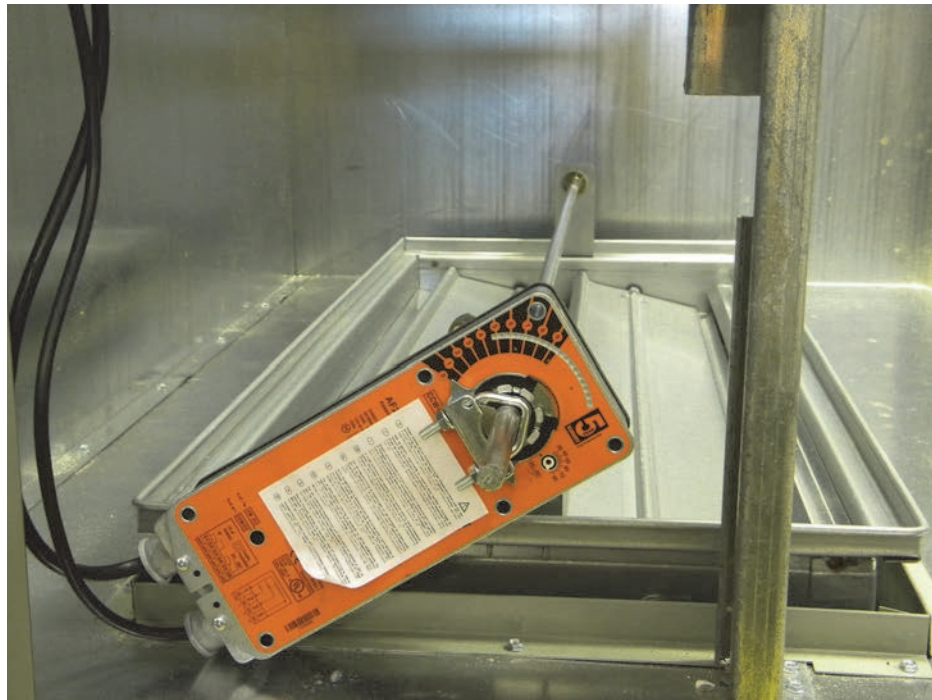

Corrosion-Inhibiting Coating

Options include stainless steel interior walls with prepainted exterior walls, ECO-coated coils, and stainless steel coil casing.

Filters

Adjustable 6-in. filter rack with options for 2-in. MERV-8, 2-in. MERV-13, and 4-in. MERV-14 installed just upstream of the evaporator coil. In addition, 2-inch aluminum mesh mist eliminators are located in the intake hood. An additional option is a 120 V UVC downstream of the evaporator coil.

Mechanical Specifications

Filter Status Switch

This option indicates when filters require cleaning or replacement. The Filter Status switch triggers an information-only diagnostic message on the human interface and will allow continued unit operation.

Non-Fused Disconnect Switch

A 3-pole, molded case, disconnect switch with provisions for through the base electrical connections shall be installed. The disconnect switch will be installed in the unit in a water tight enclosure. Wiring will be provided from the switch to the unit high voltage terminal block. The switch will be UL/CSA agency recognized. The disconnect switch will be sized per NEC and UL guidelines but will not be used in place of unit overcurrent protection.

Convenience Outlet

A convenience outlet is provided on the control side of the unit. The GFI outlet is 115 volt, and capable of manual resetting. The convenience outlet will remain powered regardless of the position of the unit disconnect.

Figure 7. Convenience outlet



Roof Mounting Curb

The roof mounting curb is fabricated of 14-gage galvanized steel with a nominal 2-in. x 2-in. nailer setup. The curb ships knocked down with a curb gasket. Curb height options are 14 or 24 inches.

Sound Attenuation Package

The unit will be equipped with variable speed, ECM condenser fans to reduce sound and increase performance. When a unit is selected with the Sound Attenuation Package, it will also be equipped with head pressure control to allow the condenser fans to run as slow as possible while maintaining the performance of the unit. This option increases the overall height of the unit at the condenser section. Refer to the submittal for unit dimensional data when Sound Attenuation Package is selected. An optional compressor sound blanket may also be selected.



Appendix

OAU Filter Guide

Table 1. OAD units

Evaporator				
Thickness, in. (cm)	MERV	Qty	Height, in. (cm)	Width, in. (cm)
2 (5.1)	8, 13	6	25 (63.5)	18 (45.7)
4 (10.2)	14	6	25 (63.5)	18 (45.7)
ERV Module				
Return Air				
Thickness, in. (cm)	MERV	Qty	Height, in. (cm)	Width, in. (cm)
2 (5.1)	8	6	20 (50.8)	20 (50.8)
Outside Air^(a)				
Thickness, in. (cm)	MERV	Qty	Height, in. (cm)	Width, in. (cm)
2 (5.1)	8	6	20 (50.8)	20 (50.8)
Inlet Hood				
Thickness, in. (cm)	Material	Qty	Height, in. (cm)	Width, in. (cm)
2 (5.1)	Aluminum Mesh	6	20 (50.8)	20 (50.8)

(a) No filters will be provided on the outside air path of the ERV section if electric preheat is provided.

Table 2. OAN units

Evaporator (40 to 50 ton - 4 and 6 row coils; 55 to 100 ton - 6 row coils)				
Thickness, in. (cm)	MERV	Qty	Height, in. (cm)	Width, in. (cm)
2 (5.1)	8, 13	15	20 (50.8)	18 (45.7)
4 (10.2)	14	15	20 (50.8)	18 (45.7)
Evaporator (55 to 100 ton - 4 row coils)				
Thickness, in. (cm)	MERV	Qty	Height, in. (cm)	Width, in. (cm)
2 (5.1)	8, 13	12	20 (50.8)	25 (63.5)
4 (10.2)	14	12	20 (50.8)	25 (63.5)
ERV Module				
Return Air				
Thickness, in. (cm)	MERV	Qty	Height, in. (cm)	Width, in. (cm)
2 (5.1)	8	15	24 (61.0)	18 (45.7)
Outside Air^(a)				
Thickness, in. (cm)	MERV	Qty	Height, in. (cm)	Width, in. (cm)
2 (5.1)	8	15	24 (61.0)	18 (45.7)
Inlet Hood				
Thickness, in. (cm)	Material	Qty	Height, in. (cm)	Width, in. (cm)
2 (5.1)	Aluminum Mesh	12	24 (61.0)	24 (61.0)

(a) No filters will be provided on the outside air path of the ERV section if electric preheat is provided.

Trane - by Trane Technologies (NYSE: TT), a global climate innovator - creates comfortable, energy efficient indoor environments for commercial and residential applications. For more information, please visit trane.com or tranetechnologies.com.

Trane has a policy of continuous product and product data improvement and reserves the right to change design and specifications without notice. We are committed to using environmentally conscious print practices.